

CERAMICHE PIEMME

FLOOR AND MORE

Catalogo Generale | 2026

INDEX

02	<u>A/Z</u>
03	<u>Looks</u>
04	<u>Sizes</u>
06	<u>About us, Made in Italy</u>
08	<u>History</u>
10	<u>Innovation. Sustainability. Design.</u>
12	<u>Synchro Digit Piemme® Technology</u>
14	<u>Piemme Slabs</u>
16	<u>Created to inspire</u>
18	<u>Stone Effect</u>
142	<u>Contemporary</u>
224	<u>Cement Effect</u>
284	<u>Wood Effect</u>
322	<u>Marble Effect</u>
368	<u>Technical Data</u>

A/Z

Serie

- 138 [Artdesia 2.0](#)
- 102 [Bits&Pieces](#)
- 122 [Castlestone](#)
- 226 [Cement Vibes](#)
- 276 [Concrete](#)
- 314 [Cottage](#)
- 74 • [Evoluta](#)
- 308 [Fleur de Bois](#)
- 216 [Fragments](#)
- 110 [Geostone](#)
- 252 [Glitch](#)
- 164 [Homey](#)
- 62 • [Ibla](#)
- 50 • [Journey](#)
- 32 • [Limestone](#)
- 350 [Majestic](#)
- 324 [Majestic Onyx](#)
- 338 [Majestic Pure Selection](#)
- 144 • [Makro Deco](#)
- 154 [Makro Project](#)
- 198 [Materia](#)
- 134 [Moon](#)
- 128 [More](#)
- 116 [Purestone](#)
- 286 [Solonoce](#)
- 296 [Solorovere](#)
- 318 [Soul](#)
- 20 • [Stone Revolution](#)
- 272 [Suprema](#)
- 88 [Uniquestone](#)
- 220 [Venetian Marble](#)

Collections LOOKS

	STONE EFFECT	CONTEMPORARY	CEMENT EFFECT	WOOD EFFECT	MARBLE EFFECT
Premium	<ul style="list-style-type: none"> 20 • Stone Revolution 32 • Limestone 50 • Journey 62 • Ibla 74 • Evoluta 	<ul style="list-style-type: none"> 144 • Makro Deco 154 Makro Project 164 Homey 	<ul style="list-style-type: none"> 226 Cement Vibes 	<ul style="list-style-type: none"> 286 Solonoce 296 Solorovere 	<ul style="list-style-type: none"> 324 Majestic Onyx 338 Majestic Pure Selection 350 Majestic
Essenza	<ul style="list-style-type: none"> 88 Uniquestone 102 Bits&Pieces 110 Geostone 116 Purestone 122 Castlestone 128 More 	<ul style="list-style-type: none"> 198 Materia 216 Fragments 	<ul style="list-style-type: none"> 252 Glitch 	<ul style="list-style-type: none"> 308 Fleur de Bois 314 Cottage 	
Emporio	<ul style="list-style-type: none"> 134 Moon 138 Artdesia 2.0 	<ul style="list-style-type: none"> 220 Venetian Marble 	<ul style="list-style-type: none"> 272 Suprema 276 Concrete 	<ul style="list-style-type: none"> 318 Soul 	



• Synchro Digit Piemme

SIZES

	120x280	120x120	60x120	20 mm 60x120	80x80	60x60	20 mm 60x60	30x120	30x60	10x60	10x53	7,5x30	60,4x60,4	30,1x60,4
STONE EFFECT														
Premium														
20	• <u>Stone Revolution</u>	■	■	■						■	■			
32	• <u>Limestone</u>	■	■	■	■	■			■	■	■			
50	• <u>Journey</u>	■	■	■		■			■					
62	• <u>Ibla</u>	■	■	■		■		■		■	■			
74	• <u>Evoluta</u>			■					■					
Essenza														
88	<u>Uniquestone</u>		■	■	■	■			■		■			
102	<u>Bits&Pieces</u>		■			■			■					
110	<u>Geostone</u>			■		■			■					
116	<u>Purestone</u>					■			■					■
122	<u>Castlestone</u>					■			■					
128	<u>More</u>								■					
Emporio														
134	<u>Moon</u>			■	■	■			■					
138	<u>Artdesia 2.0</u>			■		■	■		■					
CONTEMPORARY														
Premium														
144	• <u>Makro Deco</u>	■		■										
154	<u>Makro Project</u>	■												
164	<u>Homey</u>	■	■	■		■			■	■				
Essenza														
198	<u>Materia</u>		■	■		■			■					
216	<u>Fragments</u>											■		
Emporio														
220	<u>Venetian Marble</u>			■		■			■					
MARBLE EFFECT														
Premium														
324	<u>Majestic Onyx</u>	■	■	■										
338	<u>Majestic Pure Selection</u>	■	■	■		■								
350	<u>Majestic</u>	■	■	■		■								

	120x280	120x120	60x120	6 mm 60x120	20 mm 60x120	80x80	60x60	20 mm 60x60	30x120	20 mm 30x120	20x120	30x60	10x53	60,4x60,4	30,1x60,4
CEMENT EFFECT															
Premium															
226	<u>Cement Vibes</u>	■	■	■	■		■	■							
Essenza															
252	<u>Glitch</u>		■	■		■	■	■	■				■		
Emporio															
272	<u>Suprema</u>						■	■					■		
276	<u>Concrete</u>		■	■		■	■	■	■					■	■
WOOD EFFECT															
Premium															
286	<u>Solonoce</u>									■			■		
296	<u>Solorovere</u>								■	■	■		■		
Essenza															
308	<u>Fleur de Bois</u>			■									■		
314	<u>Cottage</u>												■		
Emporio															
318	<u>Soul</u>												■		

20 mm	20 mm 60x120	20 mm 60x60	20 mm 30x120
STONE EFFECT			
Premium			
<u>Limestone</u>	■		
Emporio			
<u>Artdesia 2.0</u>		■	
CEMENT EFFECT			
Essenza			
<u>Glitch</u>	■	■	
Emporio			
<u>Concrete</u>	■	■	
WOOD EFFECT			
Premium			
<u>Solorovere</u>			■

• Synchro Digit Piemme





ABOUT US, MADE IN ITALY

Dal 1962 Piemme produce pavimenti e rivestimenti ceramici Made in Italy dallo stile inconfondibile. Le soluzioni che fornisce sono il frutto di tanti anni di attività fatta di ricerca, esperienza e passione. Si avvale di strumenti di ultima generazione e seleziona, per i propri prodotti, materie prime di altissima qualità. Collabora con aziende che condividono gli stessi valori e che si impegnano nell'offrire soluzioni e processi sempre meno impattanti a livello ambientale.

Since 1962, Piemme has been producing Made in Italy ceramic tiles and wall coverings distinguished by an unmistakable style. Its solutions are the result of many years of research, expertise and passion. The company employs state-of-the-art technologies and carefully selects the highest-quality raw materials for its products. It works in partnership with companies that share the same values and are committed to offering solutions and processes with an increasingly reduced environmental impact.

Seit 1962 produzieren wir keramische Wand- und Bodenbeläge „Made in Italy“ mit unverwechselbarer Qualität und Stil. Die angebotenen Lösungen sind das Ergebnis von über 60 Jahren Forschung, Erfahrung und Leidenschaft. Wir verwenden modernste Werkzeuge und wählen für unsere Produkte Rohstoffe von höchster Qualität aus. Piemme arbeitet mit Unternehmen zusammen, die unsere Werte teilen und sich dazu verpflichten, immer umweltfreundlichere Lösungen und Prozesse anzubieten.

Depuis 1962, nous produisons des sols et des revêtements en céramique Made in Italy d'une qualité et d'un style incomparables. Les solutions qu'elle propose sont le résultat de plus de 60 ans d'activité faite de recherche, d'expérience et de passion. Nous utilisons des outils de dernière génération et sélectionnons des matières premières de la plus haute qualité pour nos produits. Piemme collabore avec des entreprises qui partagent les mêmes valeurs et s'engagent à proposer des solutions et des processus ayant de moins en moins d'impact sur l'environnement.



HISTORY

Shaping the future starting from the past

1962 L'inizio

Viene fondata a Maranello "Industrie Ceramiche Piemme SPA", con 13 dipendenti e una produzione giornaliera di 40 mq di pavimenti e rivestimenti ceramici.

1977 Valentino

L'anno dell'accordo con il grande stilista Valentino.

1981 Sponsorizzazioni

Le sponsorizzazioni in Formula 1 con l'indimenticabile pilota della Ferrari Gilles Villeneuve.

2002 Nuova sede

Viene inaugurata la nuova sede a Fiorano Modenese.

2013 Produzione green

Realizzato un impianto produttivo eco-sostenibile a Solignano su una superficie di 100.000 mq.

2018 Synchro Digit Piemme®

Piemme sviluppa per prima nel comprensorio ceramico di Sassuolo la nuova tecnologia di stampa digitale "Synchro Digit Piemme®".

2023 Nuove tecnologie

A inizio 2023 Piemme installa nuove tecnologie per migliorare l'efficienza e ridurre l'impatto ambientale.

2025 Percorso evolutivo

Nel 2025 sono stati potenziati i reparti di macinazione e finitura con nuove macchine, aumentando efficienza e produttività e riducendo i consumi.

1962 The beginning

"Industrie Ceramiche Piemme S.P.A." is founded in Maranello, with 13 employees and a daily production of 40 sqm of ceramic floor and wall tiles.

1977 Valentino

The year of the agreement with the great designer Valentino.

1981 Sponsorships

The Formula 1 sponsorships with the unforgettable Ferrari driver Gilles Villeneuve have given Piemme a world visibility.

2002 New headquarters

The new headquarters is being inaugurated in Fiorano Modenese.

2013 Green production

An eco-sustainable production facility was built in Solignano on an area of 100.000 sqm.

2018 Synchro Digit Piemme®

Piemme is the first to develop the new "Synchro Digit Piemme®" digital printing technology in the Sassuolo ceramic area.

2023 New Industrial Technology

At the beginning of 2023, Piemme installs new technologies and machinery with the goal of improving and reducing its environmental impact.

2025 Evolutionary path

In 2025, the grinding and finishing departments were upgraded with new machines, increasing efficiency and productivity while reducing consumption.

1962 Der Anfang

Gegründet in Maranello Industrie Ceramiche Piemme SPA mit 13 Mitarbeitern und einer täglichen Produktion von 40 qm Keramikböden und Bodenbelägen.

1977 Valentino

Das Jahr der Vereinbarung mit dem berühmten Designer Valentino.

1981 Sponsoring

Das Sponsoring in der Formel 1 mit dem unvergesslichen Ferrari-Piloten Gilles Villeneuve hat Piemme weltweit bekannt gemacht.

2002 Neuer Firmensitz

Der neue Firmensitz in Fiorano Modenese wird eingeweiht.

2013 Green Production

In Solignano wird eine umweltfreundliche Produktionsanlage auf einer Fläche von 100.000 m² realisiert.

2018 Synchro Digit Piemme®

Piemme entwickelt als erstes Unternehmen im Keramikbezirk von Sassuolo die neue digitale Drucktechnologie „Synchro Digit Piemme®“.

2023 Neue Industrietechnologien

Anfang 2023 installiert Piemme neue Technologien, um die Effizienz zu verbessern und die Umweltbelastung zu reduzieren.

2025 Innovationsweg

Im Jahr 2025 werden die Mahl- und Endbearbeitungsabteilungen mit neuen Maschinen verstärkt, wodurch Effizienz und Produktivität gesteigert und der Verbrauch reduziert werden.

1962 Le début

Fondée à Maranello Industrie Ceramiche Piemme SPA avec 13 employés et une production quotidienne de 40 m2 de sols et revêtements en céramique.

1977 Valentino

L'année de l'accord avec le grand designer Valentino.

1981 Parrainages

Les parrainages en Formule 1 avec l'inoubliable pilote Ferrari Gilles Villeneuve ont donné à Piemme une visibilité mondiale.

2002 Nouveau siège

Inauguration du nouveau siège à Fiorano Modenese.

2013 Green Production

Réalisation d'un site de production éco-responsable à Solignano, sur une superficie de 100.000 m².

2018 Synchro Digit Piemme®

Piemme développe en premier, dans le district céramique de Sassuolo la nouvelle technologie d'impression numérique « Synchro DigitPiemme® ».

2023 Nouvelles Technologies

Début 2023, Piemme installe de nouvelles technologies afin d'améliorer l'efficacité et de réduire l'impact environnemental.

2025 Parcours évoltif

En 2025, les départements de broyage et de finition sont renforcés par de nouvelles machines, augmentant l'efficacité et la productivité tout en réduisant les consommations.

INNOVATION. SUSTAINABILITY. DESIGN.

Green design, redefining tomorrow

Nel suo percorso di crescita, Piemme ha continuato a investire in innovazione e sostenibilità, sviluppando un modello produttivo sempre più moderno e responsabile. Il 2023 ha rappresentato una svolta tecnologica significativa con l'introduzione di impianti all'avanguardia che hanno migliorato la qualità del prodotto, ottimizzato i consumi energetici e reso i processi più sostenibili. Nel biennio 2024-2025, nuovi interventi strategici hanno aumentato la capacità produttiva, migliorando al contempo stabilità ed efficienza operativa. Con queste azioni, Piemme rafforza la propria visione industriale, che integra innovazione, sostenibilità e qualità, dando vita a una produzione ceramica sempre più avanzata, consapevole e orientata al cambiamento.

Throughout its growth, Piemme has continued to invest in innovation and sustainability, developing an increasingly modern and responsible production model. The year 2023 marked a significant technological turning point with the introduction of cutting-edge systems that improved product quality, optimized energy consumption, and made processes more sustainable. In the 2024-2025 period, new strategic initiatives have boosted production capacity while also enhancing operational stability and efficiency. Through these efforts, Piemme reinforces its industrial vision, which blends innovation, sustainability, and quality, giving rise to an increasingly advanced, conscious, and change-driven ceramic production.

Im Zuge ihres kontinuierlichen Wachstums investiert Piemme konsequent in Innovation und Nachhaltigkeit und entwickelt ein Produktionsmodell, das modern, effizient und verantwortungsvoll ist. Das Jahr 2023 markierte einen entscheidenden technologischen Meilenstein: Mit der Einführung hochmoderner Anlagen konnte die Produktqualität weiter gesteigert, der Energieverbrauch optimiert und die Nachhaltigkeit der Prozesse deutlich verbessert werden. In den Jahren 2024-2025 stärkten gezielte strategische Investitionen die Produktionskapazität und sorgten zugleich für höhere Stabilität und operative Effizienz. Mit diesem Weg festigt Piemme ihre industrielle Vision, in der Innovation, Nachhaltigkeit und Qualität verschmelzen – für eine Keramikproduktion, die zukunftsorientiert ist und den Wandel aktiv gestaltet.

Dans sa dynamique de croissance, Piemme investit continuellement dans l'innovation et la durabilité, en façonnant un modèle de production toujours plus moderne, performant et responsable. L'année 2023 a marqué une étape technologique clé avec l'intégration de solutions de pointe, capables d'élever la qualité des produits, d'optimiser la consommation énergétique et de renforcer la durabilité des processus. Entre 2024 et 2025, de nouveaux investissements stratégiques ont permis d'accroître la capacité de production tout en améliorant la stabilité et l'efficacité opérationnelle. À travers ces choix, Piemme affirme sa vision industrielle, où innovation, durabilité et qualité s'unissent pour donner vie à une céramique d'avant-garde, consciente et résolument tournée vers l'avenir.

▶ WATCH THE VIDEO



INDEX



INDEX

SYNCHRO DIGIT PIEMME® TECHNOLOGY

Where technology meets the art of ceramics



La tecnologia Synchro Digit Piemme, combinata con la Linea Continua, permette di creare superfici illimitate e di grande impatto visivo, anche su lastre di grande formato.

Questo processo innovativo garantisce un perfetto equilibrio tra struttura e grafica, con effetti tattili straordinari che conferiscono un valore unico ai prodotti finiti.

A differenza dei metodi tradizionali, la superficie tridimensionale non viene più creata mediante pressatura, superando così le limitazioni imposte dai classici stampi ceramici e aprendo la strada a un'ampia gamma di possibilità creative. Ogni progetto può così vantare dettagli ad alta definizione e una ricchezza materica senza precedenti.

Piemme's Synchro Digit technology, combined with the Continuous Line system, enables the creation of limitless, visually striking surfaces, even on large-format slabs.

This innovative process ensures a perfect balance between structure and design, with extraordinary tactile effects that add unique value to the finished products.

Unlike traditional methods, the three-dimensional surface is no longer created through pressing, thus overcoming the limitations of conventional ceramic molds and opening the door to a wide range of creative possibilities.

As a result, every project features high-definition details and an unprecedented material richness.

Die Synchro Digit Piemme Technologie in Kombination mit der „Contina Line“ ermöglicht die Gestaltung grenzenloser Oberflächen mit starker visueller Wirkung – auch auf Großformatplatten.

Dieses innovative Verfahren schafft ein perfektes Gleichgewicht zwischen Struktur und Grafik und erzeugt außergewöhnliche haptische Effekte, die den fertigen Produkten einen einzigartigen Mehrwert verleihen.

Im Gegensatz zu traditionellen Methoden wird die dreidimensionale Oberfläche nicht mehr durch Pressung erzeugt. Dadurch werden die Beschränkungen klassischer Keramikformen überwunden und der Weg für ein breites Spektrum kreativer Möglichkeiten geöffnet. Jedes Projekt zeichnet sich durch hochauflösende Details und eine bislang unerreichte Materialtiefe aus.

La technologie Synchro Digit Piemme, associée à la « Ligne Continua », permet de créer des surfaces infinies à fort impact visuel, y compris sur des dalles de grand format.

Ce procédé innovant garantit un équilibre parfait entre structure et graphisme, offrant des effets tactiles exceptionnels qui confèrent une valeur unique aux produits finis.

Contrairement aux méthodes traditionnelles, la surface tridimensionnelle n'est plus obtenue par pressage : les contraintes imposées par les moules céramiques classiques sont ainsi dépassées, ouvrant la voie à une liberté créative inédite.

Chaque projet se distingue par des détails en haute définition et une richesse de matière sans précédent.

 [WATCH THE VIDEO](#)



PIEMME SLABS

Innovate, Create, Captivate

Le lastre Piemme nascono per realizzare ambienti total look. Disponibili in diversi effetti e colori, sono il perfetto connubio tra estetica e funzionalità. Makro Deco e Makro Project sono due contenitori tematici pensati per la progettazione di ambienti coordinati, su misura e in larga scala, sia in ambito residenziale che contract. Makro Deco raccoglie tutte le soluzioni decorative su lastra, realizzate per valorizzare il grande formato attraverso pattern studiati per garantire continuità visiva e forte impatto estetico. Makro Project è ideato per rispondere alle esigenze specifiche del mondo contract, dell'hospitality e dell'arredamento nautico, offrendo anche formati personalizzabili su richiesta.

Piemme slabs are designed to create fully coordinated environments. Available in a variety of effects and colors, they offer the perfect balance of aesthetics and functionality. Makro Deco and Makro Project are two thematic collections designed for the creation of coordinated, custom-made, large-scale spaces, both in residential and commercial settings. Makro Deco brings together all decorative slab solutions, crafted to enhance large formats through patterns designed to ensure visual continuity and a strong aesthetic impact. Makro Project is designed to meet the specific needs of the contract, hospitality, and nautical furniture sectors, also offering customizable sizes upon request.

Die Großformatplatten von Piemme sind für die Gestaltung von Total-Look-Konzepten entworfen. Erhältlich in unterschiedlichen Effekten und Farben, vereinen sie Ästhetik und Funktionalität in perfekter Balance. Makro Deco und Makro Project sind zwei thematische Designwelten, die für die Planung koordinierter, maßgeschneiderter und großflächiger Raumkonzepte entwickelt wurden – sowohl im Wohn- als auch im Objektbereich. Makro Deco bündelt dekorative Lösungen auf Großformatplatten, die das Potenzial des großen Formats durch speziell entwickelte Muster unterstreichen und für visuelle Kontinuität sowie eine starke ästhetische Wirkung sorgen. Makro Project wurde entwickelt, um den spezifischen Anforderungen des Contract, Hospitality und Yacht-Bereichs gerecht zu werden und bietet zudem auf Anfrage individuell anpassbare Formate.

Les dalles grand format Piemme sont conçues pour créer des environnements total look. Disponibles dans une large gamme d'effets et de couleurs, elles représentent l'alliance parfaite entre esthétique et fonctionnalité. Makro Deco et Makro Project sont deux univers thématiques pensés pour la conception d'espaces coordonnés, sur mesure et à grande échelle, aussi bien dans le résidentiel que dans le contract. Makro Deco rassemble toutes les solutions décoratives sur dalle, conçues pour sublimer le grand format grâce à des motifs étudiés afin de garantir une continuité visuelle et un fort impact esthétique. Makro Project répond aux exigences spécifiques des secteurs contract, hospitality et du mobilier nautique, en proposant également des formats personnalisables sur demande.



ADI
DESIGN
INDEX

Selezione Compasso d'Oro

CREATED TO INSPIRE.

Spaces that tell a story

Ogni superficie nasce per dialogare con il progetto, trasformando la materia in linguaggio ed equilibrio. Con uno sguardo attento all'architettura e al design, Piemme crea soluzioni versatili e su misura per luoghi che accolgono, ispirano e lasciano un segno. La collaborazione con designers e artisti di fama internazionale, tra cui Benoy, Guillaumier, Charpin e Paola Paronetto - la cui linea è stata selezionata per il premio ADI Design Index 2025 -, riflette l'impegno costante nella ricerca della qualità e dell'eccellenza nel design.

Each surface is designed to engage with the project, transforming material into both language and balance. With a keen eye on architecture and design, Piemme creates versatile, custom solutions for spaces that welcome, inspire, and leave a lasting impression. Collaboration with internationally renowned designers and artists, including Benoy, Guillaumier, Charpin and Paola Paronetto—whose collection has been selected for the ADI Design Index 2025 award—reflects the company's ongoing commitment to the pursuit of quality and excellence in design.

Jede Oberfläche entsteht im Dialog mit dem Projekt und verwandelt Material in Ausdruck und Balance. Mit einem aufmerksamen Blick für Architektur und Design entwickelt Piemme vielseitige, maßgeschneiderte Lösungen für Räume, die empfangen, inspirieren und einen bleibenden Eindruck hinterlassen. Die Zusammenarbeit mit international renommierten Designern und Künstlern wie Benoy, Guillaumier, Charpin und Paola Paronetto – deren Kollektion für den ADI Design Index 2025 ausgewählt wurde – spiegelt das kontinuierliche Engagement von Piemme für Qualität und Exzellenz im Design wider.

Chaque surface naît pour dialoguer avec le projet, transformant la matière en langage et en harmonie. Avec une attention particulière portée à l'architecture et au design, Piemme crée des solutions polyvalentes et sur mesure pour des lieux qui accueillent, inspirent et laissent une empreinte durable. La collaboration avec des designers et artistes de renommée internationale, tels que Benoy, Guillaumier, Charpin et Paola Paronetto – dont la collection a été sélectionnée pour l'ADI Design Index 2025 – témoigne de l'engagement constant de Piemme dans la recherche de la qualité et de l'excellence en design.

▶ WATCH THE VIDEO

STONE EFFECT

Effetto Pietra / Natursteinoptik / Effet Pierre



- 20 Stone Revolution PREMIUM /
- 32 Limestone PREMIUM /
- 50 Journey PREMIUM /
- 62 Ibla PREMIUM /
- 74 Evoluta PREMIUM /
- 88 Uniquestone ESSENZA /
- 102 Bits&Pieces ESSENZA /
- 110 Geostone ESSENZA /
- 116 Purestone ESSENZA /
- 122 Castlestone ESSENZA /
- 128 More ESSENZA /
- 134 Moon EMPORIO /
- 138 Artdesia 2.0 EMPORIO /



Stone Revolution

La collezione Stone Revolution nasce per accogliere una varietà di superfici, per pavimenti e rivestimenti, che riproducono la bellezza e la texture della pietra. Ogni pezzo è un invito a esplorare un mondo dove la ceramica si trasforma in un elemento di pregio, capace di donare calore e carattere ad ogni ambiente.

The Stone Revolution collection is designed to offer a variety of surfaces for floors and walls that replicate the beauty and texture of natural stone. This collection will progressively expand with new creations, each intended to evoke the harmony between nature and design. Each piece is an invitation to explore a world where ceramics become a valuable element, capable of adding warmth and character to any environment.

Die Stone Revolution Kollektion ist darauf ausgelegt, eine Vielzahl von Oberflächen für Böden und Wände anzubieten, die die Schönheit und Textur von Stein nachbilden. Diese Kollektion wird sich fortlaufend mit neuen Kreationen erweitern, die alle darauf abzielen, die Harmonie zwischen Natur und Design zu beschwören. Jedes Stück ist eine Einladung, eine Welt zu entdecken, in der Keramik zu einem wertvollen Element wird, das jedem Raum Wärme und Charakter verleiht.

La collection Stone Revolution est conçue pour offrir une variété de surfaces pour les sols et les murs qui reproduisent la beauté et la texture de la pierre. Cette collection s'enrichira progressivement de nouvelles créations, chacune visant à évoquer l'harmonie entre la nature et le design. Chaque pièce est une invitation à explorer un monde où la céramique se transforme en un élément précieux, capable d'apporter chaleur et caractère à tout environnement.

4

Colori
Colours
Farben
Couleurs



5

Formati
Sizes
Formate
Formats

120×280
48"×110"



120×120
48"×48"



60×120
24"×48"



10×60
4"×24"



10×53
4"×20"



1

Superfici
Surfaces
Oberflächen
Surfaces

Satin

i



Tecnologia - Technology - Technologie:
Synchro Digit Piemme®
Superficie con struttura digitale sincronizzata
Synchronized digital structured surface
Im synchronisierten Digitaldruckverfahren
hergestellte 3D-Oberfläche
Surface avec texture et finition par
impression numérique synchronisée

Gres fine porcellanato ad impasto colorato
Coloured-body fine porcelain stoneware
Feinsteinzeug aus farbiger Masse
Grès cérame fin à pâte colorée

Effetto Pietra
Stone Look
Natursteinoptik
Effet Pierre

Rivestimento
Wall Tiles
Wandfliesen
Revêtement

Pavimento
Floor Tiles
Bodenfliesen
Sol

Ripresa grafica tra le diverse lastre rettificata contenuta entro le tolleranze previste dalla norma. Per un corretto allineamento si consiglia di utilizzare una fuga di 2 mm.
Graphic representation between the rectified tiles is contained within the tolerances provided by the standard. For a correct alignment it is recommended to use a 2 mm joint.

Grafische Darstellung zwischen den verschiedenen rektifizierten Platten innerhalb der in der Norm vorgesehenen Toleranzen. Für eine korrekte Anpassung wird eine Fuge von 2mm empfohlen.
Reproduction graphique entre les différents carreaux rectifiés dans les limites des tolérances prévues par la norme. Pour un alignement correct, il est recommandé d'utiliser joints de 2 mm.



Stone Revolution

Stone Effect
PREMIUM

Travertino Ivory



120×280
06104 | Travertino Ivory Satin/Ret



120×120
06096 | Travertino Ivory Satin/Ret

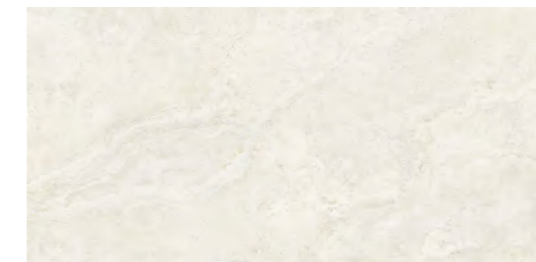

60×120
06100 | Travertino Ivory Satin/Ret



10×60
06195 | Listoncino Travertino Ivory Satin/Ret

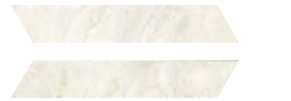

10×53
06189 | Chevron Travertino Ivory Satin/Ret



30×30
06198 | Jenga Travertino Ivory Satin/Ret

Travertino Creme



120x280
06105 | Travertino Creme Satin/Ret



120x120
06097 | Travertino Creme Satin/Ret



10x60
06196 | Listoncino Travertino Creme Satin/Ret



10x53
06190 | Chevron Travertino Creme Satin/Ret



30x30
06199 | Jenga Travertino Creme Satin/Ret

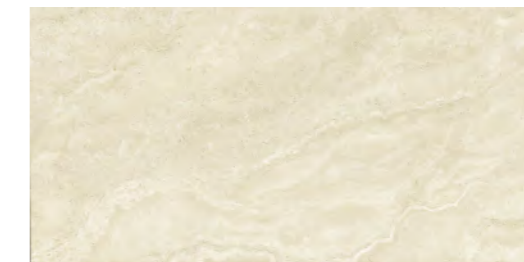

60x120
06101 | Travertino Creme Satin/Ret

Stone Revolution

Grey Red



120x280
06103 | Grey Red Satin/Ret



120x120
06095 | Grey Red Satin/Ret



60x120
06099 | Grey Red Satin/Ret



10x60
06194 | Listoncino Grey Red Satin/Ret



10x53
06188 | Chevron Grey Red Satin/Ret



30x30
06197 | Jenga Grey Red Satin/Ret



30x30
06193 | Ajaba Grey Red Satin/Ret

Calacatta Iron



120x280
06102 | Calacatta Iron Satin/Ret

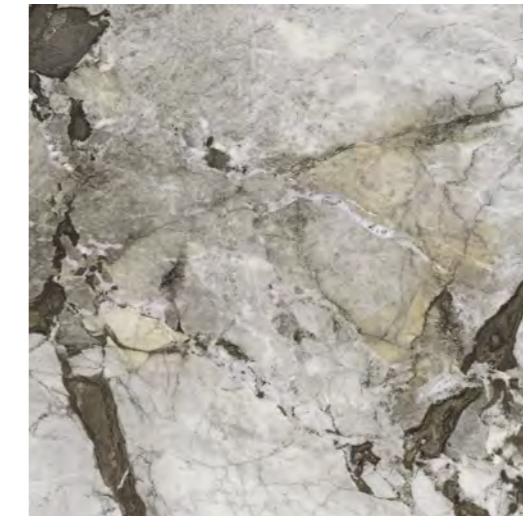

120x120
06094 | Calacatta Iron Satin/Ret



60x120
06098 | Calacatta Iron Satin/Ret

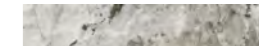

10x60
06192 | Listoncino Calacatta Iron Satin/Ret



10x53
06187 | Chevron Calacatta Iron Satin/Ret



28,3x29,7
06191 | Esagono Calacatta Iron Satin/Ret

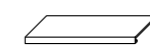
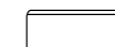

Imballi

Packing
Verpackung
Emballage



Riepilogo Gamma

Collection
Serie
Gamme

[PDF Merchandising](#)



Formati Sizes	P	I MM							
			Pezzi Scatola Pieces/Box Stck/Karton Carreaux/Boite	Mq/Scatola Sqmt/Box Qm/Karton M2/Boite	Kg/Scatola Kgs/Box Kg/Karton Kg/Boite	Scatole/Paletta Boxes/Pallet Karton/Palette Boite/Palette	Mq/Paletta Sqmt/Pallet Qm/Pallet M2/Palette	Kg/Paletta Kgs/Pallet Kg/Pallet Kg/Palette	Formato Paletta Size Pallet Format Pallet Dim. Palette
120x280 (48"x110") Satin/Ret	P	6,0	1	3,36	46,50	20	67,20	930	143x294x35
120x120 (48"x48") Satin/Ret	P	8,5	2	2,88	55,00	24	69,12	1320	135x122x68
60x120 (24"x48") Satin/Ret	P	8,5	2	1,44	28,00	44	63,36	1232	122x100x76
10x60 (4"x48") Listoncino Satin/Ret	P	8,5	10	0,60	11,20	72	43,20	806,40	120x80x75
10x53 (4"x20") Chevron Satin/Ret	P	8,5	12	0,64	11,90	60	38,40	714	120x80x75
30x30 (12"x12") Jenga Satin/Ret	P	8,5	6	0,54	10,20	60	-	-	-
30x30 (12"x12") Ajaba Satin/Ret	P	8,5	6	0,54	10,20	60	-	-	-
28,3x29,7 (11"x11½") Esagono Satin/Ret	P	8,5	7	0,59	9,80	60	-	-	-
Pezzi Speciali / Special Pieces									
33x120 (13"x48") Gradino Costa Retta Satin/Ret	P	8,5	2	0,79	15,60	20	-	-	-
4,5x60 (1½"x24") Battiscopa Satin/Ret	P	8,5	14	0,38	8,00	80	-	-	-

Formati Sizes	Pezzi Speciali Special Pieces	120x280 48"x110"		120x120 48"x48"	60x120 24"x48"	Listoncino 10x60 4"x24"	Chevron 10x53 4"x20"	EN 16165C		Jenga 30x30 12"x12"	Ajaba 30x30 12"x12"	Esagono 28,3x29,7 11"x11½"	Gradino Costa Retta 33x120 - 13"x48"	Battiscopa 4,5x60 1½"x24"
				8,5	8,5	8,5	8,5			8,5	8,5	8,5	8,5	8,5
Satin/Ret 06104		06096	06100	06195	06189	V2	R9	06198				06174	06170	
Satin/Ret 06105		06097	06101	06196	06190	V2	R9	06199				06175	06171	
Satin/Ret 06103		06095	06099	06194	06188	V2	R9	06197	06193			06173	06169	
Satin/Ret 06102		06094	06098	06192	06187	V3	R9			06191		06172	06168	



Limestone

La bellezza della pietra calcarea nata dai fondali marini e lavorata nel corso del tempo dall'acqua. Dalla colorazione profonda e dalle piccole imperfezioni che la rendono unica. Peculiarità di una pietra naturale che vengono magistralmente riprodotte in questa nuova proposta.

The beauty of limestone, sourced from the seabed where it has been shaped over time by water, with its rich coloring and small imperfections making it a unique and timeless material, has been masterfully recreated in this new collection.

Die Schönheit des Kalksteins, der sich im Meeresboden bildet und im Laufe der Zeit vom Wasser geformt wird, mit seinen tiefen Farben und den kleinen Unvollkommenheiten, die ihn einzigartig machen. Besonderheiten eines Natursteins, die in diesem neuen Vorschlag meisterhaft reproduziert werden.

La beauté de la pierre calcaire, née des fonds marins et travaillée au fil du temps par l'eau, la couleur profonde et les petites imperfections qui la rendent unique. Caractéristiques d'une pierre naturelle qui sont magistralement reproduites dans cette nouvelle proposition.

6

Colori
Colours
Farben
Couleurs

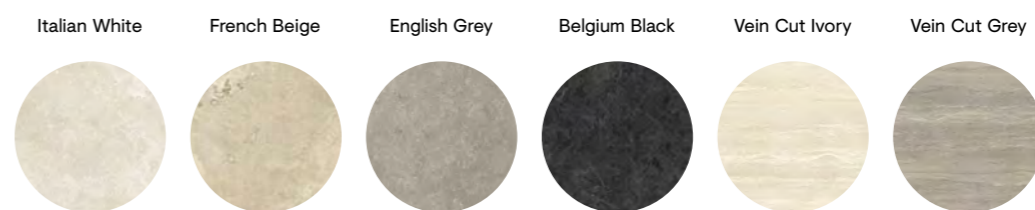

8

Formati
Sizes
Formate
Formats

120×280 48"×110"	120×120 48"×48"	60×120 24"×48"	80×80 31½"×31½"	60×60 24"×24"	30×60 12"×24"	10×60 4"×24"	10×53 4"×20"

4

Superfici
Surfaces
Oberflächen
Surfaces

Naturale Lappato Antislip Grip

1

Strutture 3D
3D structures
Strukturen
Décorations en relief

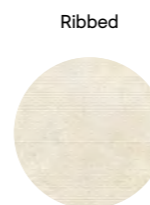

i



Tecnologia - Technology - Technologie:
Synchro Digit Piemme®
Superficie con struttura digitale sincronizzata
Synchronized digital structured surface
Im synchronisierten Digitaldruckverfahren hergestellte 3D-Oberfläche
Surface avec texture et finition par impression numérique synchronisée

Gres fine porcellanato ad impasto colorato
Coloured-body fine porcelain stoneware
Feinsteinzeug aus farbiger Masse
Grès cérame fin à pâte colorée

Effetto Pietra
Stone Look
Natursteinoptik
Effet Pierre

Rivestimento
Wall Tiles
Wandfliesen
Revêtement

Pavimento
Floor Tiles
Bodenfliesen
Sol

Ripresa grafica tra le diverse lastre rettificata contenuta entro le tolleranze previste dalla norma. Per un corretto allineamento si consiglia di utilizzare una fuga di 2 mm.
Graphic representation between the rectified tiles is contained within the tolerances provided by the standard. For a correct alignment it is recommended to use a 2 mm joint.
Grafische Darstellung zwischen den verschiedenen rektifizierten Platten innerhalb der in der Norm vorgesehenen Toleranzen. Für eine korrekte Anpassung wird eine Fuge von 2mm empfohlen.
Reproduction graphique entre les différents carreaux rectifiés dans les limites des tolérances prévues par la norme. Pour un alignement correct, il est recommandé d'utiliser joints de 2 mm.





Limestone

Stone Effect
PREMIUM

Italian White



120x280
05482 | Italian White Nat/Ret



60x120
Synchro Digit Piemme® Technology
05508A | Italian White Nat/Ret
05515A | Italian White Lap/Ret

05574A | Italian White Antislip/Ret
05576 | Italian White Grip/Ret \pm 20mm



120x120
05477 | Italian White Nat/Ret



80x80
Synchro Digit Piemme® Technology
06396 | Italian White Nat/Ret

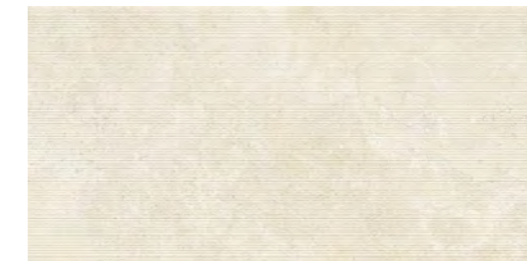

60x120
05598A | Ribbed Italian White Nat/Ret



60x60
Synchro Digit Piemme® Technology
05499 | Italian White Nat/Ret
05504 | Italian White Lap/Ret

05572 | Italian White Antislip/Ret



30x60
Synchro Digit Piemme® Technology
05491 | Italian White Nat/Ret
05495 | Italian White Lap/Ret

05570 | Italian White Antislip/Ret



10x60
05541 | Listoncino Italian White Nat/Ret
05545 | Listoncino Italian White Lap/Ret

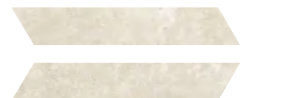

10x53
05549 | Chevron Italian White Nat/Ret
05554 | Chevron Italian White Lap/Ret

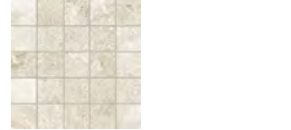

30x30
05586 | Mosaico Mix Italian White Lap/Nat



28,2x28,5
05590 | Opus Mix Italian White Lap/Nat

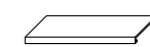
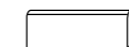

Limestone

French Beige



120x280
05483 | French Beige Nat/Ret



60x120
Synchro Digit Piemme® Technology
05509A | French Beige Nat/Ret
05516A | French Beige Lap/Ret
05575A | French Beige Antislip/Ret
05577A | French Beige Grip/Ret ± 20mm



120x120
05478 | French Beige Nat/Ret



80x80
Synchro Digit Piemme® Technology
06397 | French Beige Nat/Ret



60x120
05599A | Ribbed French Beige Nat/Ret



60x60
Synchro Digit Piemme® Technology
05501 | French Beige Nat/Ret
05505 | French Beige Lap/Ret
05573 | French Beige Antislip/Ret

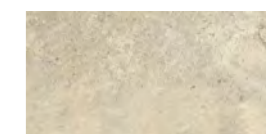

30x60
Synchro Digit Piemme® Technology
05492 | French Beige Nat/Ret
05496 | French Beige Lap/Ret

05571 | French Beige Antislip/Ret



10x60
05542 | Listoncino French Beige Nat/Ret
05546 | Listoncino French Beige Lap/Ret

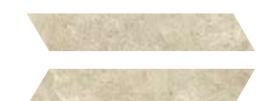

10x53
05551 | Chevron French Beige Nat/Ret
05555 | Chevron French Beige Lap/Ret

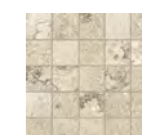

30x30
05587 | Mosaico Mix French Beige Lap/Nat



28,2x28,5
05591 | Opus Mix French Beige Lap/Nat

Limestone

English Grey



120x280
05484 | English Grey Nat/Ret



60x60
05479 | English Grey Nat/Ret



60x60
Synchro Digit Piemme® Technology
05502 | English Grey Nat/Ret
05506 | English Grey Lap/Ret



30x60
Synchro Digit Piemme® Technology
05493 | English Grey Nat/Ret
05497 | English Grey Lap/Ret



60x120
Synchro Digit Piemme® Technology
05511A | English Grey Nat/Ret
05517A | English Grey Lap/Ret
05578 | English Grey Grip/Ret ± 20mm



10x60
05543 | Listoncino English Grey Nat/Ret
05547 | Listoncino English Grey Lap/Ret



10x53
05552 | Chevron English Grey Nat/Ret
05556 | Chevron English Grey Lap/Ret



60x120
05601A | Ribbed English Grey Nat/Ret

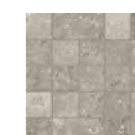

30x30
05588 | Mosaico Mix English Grey Lap/Nat



28,2x28,5
05592 | Opus Mix English Grey Lap/Nat

Limestone

Belgium Black



120x280
05485 | Belgium Black Nat/Ret

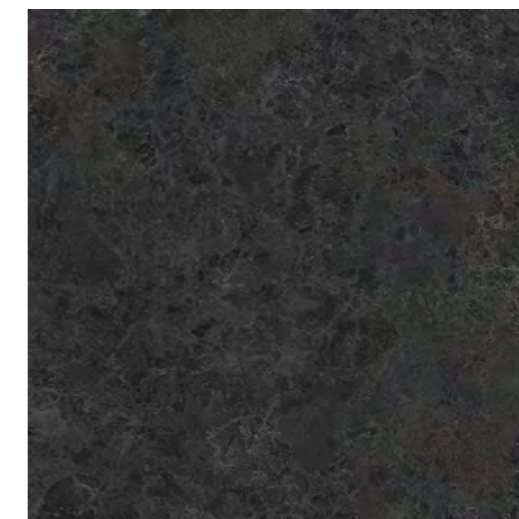

60x60
05481 | Belgium Black Nat/Ret

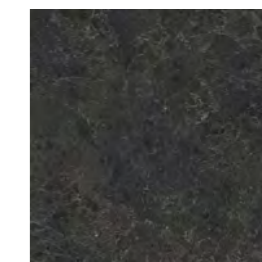

60x60
Synchro Digit Piemme® Technology
05503 | Belgium Black Nat/Ret
05507 | Belgium Black Lap/Ret



30x60
Synchro Digit Piemme® Technology
05494 | Belgium Black Nat/Ret
05498 | Belgium Black Lap/Ret



60x120
Synchro Digit Piemme® Technology
05512A | Belgium Black Nat/Ret
05518A | Belgium Black Lap/Ret



10x60
05544 | Listoncino Belgium Black Nat/Ret
05548 | Listoncino Belgium Black Lap/Ret



10x53
05553 | Chevron Belgium Black Nat/Ret
05557 | Chevron Belgium Black Lap/Ret

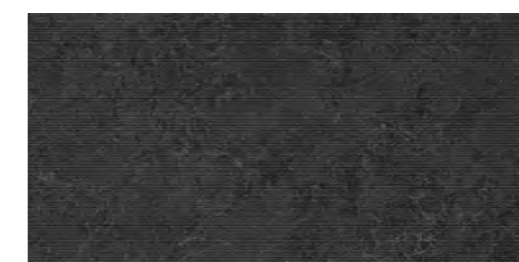

60x120
05602A | Ribbed Belgium Black Nat/Ret

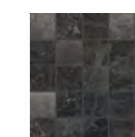

30x30
05589 | Mosaico Mix Belgium Black Lap/Nat



28,2x28,5
05593 | Opus Mix Belgium Black Lap/Nat

Limestone

Vein Cut Ivory



120x280
05526 | Vein Cut Ivory Nat/Ret



60x120
Synchro Digit Piemme® Technology
05522A | Vein Cut Ivory Nat/Ret
05524A | Vein Cut Ivory Lap/Ret

Limestone

Vein Cut Grey



120x280
05527 | Vein Cut Grey Nat/Ret



60x120
Synchro Digit Piemme® Technology
05523A | Vein Cut Grey Nat/Ret
05525A | Vein Cut Grey Lap/Ret



Limestone

Imballi

Packing
Verpackung
Emballage

Stone Effect
PREMIUM







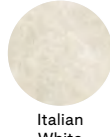

Formati Sizes		± MM	Pezzi Scatola Pieces/Box Stck/Karton Carreaux/Boîte	Mq/Scatola Sqmt/Box Qm/Karton M2/Boîte	Kg/Scatola Kgs/Box Kg/Karton Kg/Boîte	Scatole/Paletta Boxes/Pallet Karton/Palette Boîte/Palette	Mq/Paletta Sqmt/Pallet Qm/Pallet M2/Palette	Kg/Paletta Kgs/Pallet Kg/Pallet Kg/Palette	Formato Paletta Size Pallet Format Pallet Dim. Palette
120×280 (48"×110") Nat/Ret	P	6,0	1	3,36	46,50	20	67,20	930	143x294x35
120×120 (48"×48") Nat/Ret	P	8,5	2	2,88	55,00	24	69,12	1320	135x122x68
60×120 (24"×48") Nat/Ret - Lap/Ret - Antislip/Ret	P	8,5	2	1,44	28,00	44	63,36	1232	122x100x76
60×120 (24"×48") Grip/Ret	P	20	1	0,72	33,00	36	25,92	1188	122x95x75
60×120 (24"×48") (A) Grip/Ret	P	20	1	0,72	33,00	30	21,26	990	122x95x75
60×120 (24"×48") Ribbed Nat/Ret	P	8,5	2	1,44	28,00	44	63,36	1232	122x100x76
80×80 (31½"×31½") Nat/Ret	P	8,5	2	1,28	24,50	54	69,12	1323	124x80x96
60×60 (24"×24") Nat/Ret - Lap/Ret - Antislip/Ret	P	8,5	4	1,44	26,00	40	57,6	1040	122x82x75
30×60 (12"×24") Nat/Ret - Lap/Ret - Antislip/Ret	P	8,5	7	1,26	22,50	48	60,48	1080	120x80x75
28,2×28,5 (11"×11¼") Opus Mix Lap/Nat	P	8,5	6	0,48	9,50	60	-	-	-
30×30 (12"×12") Mosaico Mix Lap/Nat	P	8,5	5	0,45	8,50	60	-	-	-
Pezzi Speciali / Special Pieces									
33×120 (13"×48") Gradino Costa Retta Nat/Ret	P	8,5	2	0,79	15,60	20	-	-	-
4,5×60 (1¼"×24") Battiscopa Nat/Ret - Lap/Ret	P	8,5	14	0,38	7,10	80	-	-	-

Limestone

Riepilogo Gamma

Collection
Serie
Gamme

Formati Sizes	120*280 48"×110"	120*120 48"×48"	60*120 24"×48"	60*120 24"×48"	80*80 31½"×31½"	60*60 24"×24"	30*60 12"×24"	Listoncino 10*60 4"×24"	Chevron 10*53 4"×20"	EN 16165C	EN 16165A	DCOF	BS EN 16165: 2021-C	
														± 6,0
 Italian White	Nat/Ret	05482	05477	05508A	06396	05499	05491	05541	05549	V2	R10	A+B	>0.42	wet, dry>36
	Lap/Ret			05515A		05504	05495	05545	05554		R11	A+B+C	>0.42	wet, dry>36
	Antislip/Ret			05574A		05572	05570				R11	A+B+C	>0.42	wet, dry>36
	Grip/Ret				05576									
 French Beige	Nat/Ret	05483	05478	05509A	06397	05501	05492	05542	05551	V2	R10	A+B	>0.42	wet, dry>36
	Lap/Ret			05516A		05505	05496	05546	05555		R11	A+B+C	>0.42	wet, dry>36
	Antislip/Ret			05575A		05573	05571				R11	A+B+C	>0.42	wet, dry>36
	Grip/Ret				05577A									
 English Grey	Nat/Ret	05484	05479	05511A		05502	05493	05543	05552	V2	R10	A+B	>0.42	wet, dry>36
	Lap/Ret			05517A		05506	05497	05547	05556		R11	A+B+C	>0.42	wet, dry>36
	Grip/Ret				05578									
 Belgium Black	Nat/Ret	05485	05481	05512A		05503	05494	05544	05553	V2	R10	A+B	>0.42	wet, dry>36
	Lap/Ret			05518A		05507	05498	05548	05557					
 Vein Cut Ivory	Nat/Ret	05526		05522A						V2	R10	A+B	>0.42	wet, dry>36
	Lap/Ret			05524A										
 Vein Cut Grey	Nat/Ret	05527		05523A						V2	R10	A+B	>0.42	wet, dry>36
	Lap/Ret			05525A										







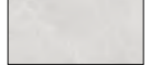

Limestone

Riepilogo Gamma

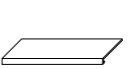
Collection
Serie
Gamme

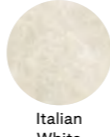
PDF Merchandising



Formati Sizes	Strutture 3D 3D Structures	Mosaico Mix 30*30 12"×12"	Opus Mix 28,2*28,5 11"×11½"	Pezzi Speciali Special Pieces	
				Gradino Costa Retta 33*120 13"×48"	Battiscopa 4,5*60 1¾"×24"
					
	Ribbed 60*120 24"×48"	Mosaico Mix 30*30 12"×12"	Opus Mix 28,2*28,5 11"×11½"	Gradino Costa Retta 33*120 13"×48"	Battiscopa 4,5*60 1¾"×24"
	± 8,5	± 8,5	± 8,5	± 8,5	± 8,5
 Italian White	Nat/Ret	05598A		05566	05558
	Lap/Ret				05562
	Lap/Nat		05586	05590	
 French Beige	Nat/Ret	05599A		05567	05559
	Lap/Ret				05563
	Lap/Nat		05587	05591	
 English Grey	Nat/Ret	05601A		05568	05560
	Lap/Ret				05564
	Lap/Nat		05588	05592	
 Belgium Black	Nat/Ret	05602A		05569	05561
	Lap/Ret				05565
	Lap/Nat		05589	05593	



Journey

Interpretata come un viaggio attraverso i paesaggi del Nord Europa, Journey è la sintesi di tutte quelle caratteristiche che permettono di definire spazi accoglienti e naturali in grado di esprimere, attraverso colori, superfici, formati e decori, i gusti contemporanei del mondo dell'interior design.

Interpreted as a journey through the landscapes of Northern Europe, Journey is the synthesis of all those characteristics that allow to define welcoming and natural areas able to express, through colors, surfaces, sizes and decorations, the contemporary taste of the world of interior design.

Journey ist die Synthese all jener Eigenschaften einer Reise durch die Landschaften Nordeuropas, die es ermöglichen, einladende und natürliche Räume zu definieren, die in der Lage sind, durch Farben, Oberflächen, Formate und Dekorationen den zeitgenössischen Geschmack der Innenarchitektur auszudrücken.

Interprétée comme un voyage à travers les paysages de l'Europe du Nord, la série Journey est la synthèse de toutes les caractéristiques qui permettent de définir des espaces accueillants et naturels en mesure d'exprimer, à travers des couleurs, des surfaces, formats et décors, les goûts contemporains du monde du design d'intérieur.

4

Colori
Colours
Farben
Couleurs

Journey Otta Journey Sarek Journey Cumbria Journey Lomond



5

Formati
Sizes
Formate
Formats

120×280 48"×110"	120×120 48"×48"	60×120 24"×48"	60×60 24"×24"	30×60 12"×24"

3

Superfici
Surfaces
Oberflächen
Surfaces

Naturale Silk Antislip

4

Strutture 3D
3D structures
Strukturen
Décorations en relief

Wave Flute Scratch Tetris

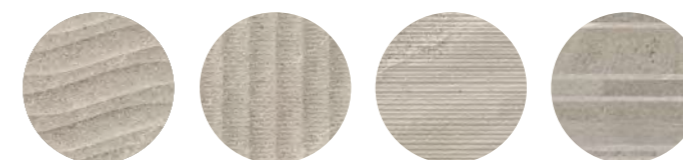

i



Tecnologia - Technology - Technologie:
Synchro Digit Piemme®
Superficie con struttura digitale sincronizzata
Synchronized digital structured surface
Im synchronisierten Digitaldruckverfahren
hergestellte 3D-Oberfläche
Surface avec texture et finition par
impression numérique synchronisée

Gres fine porcellanato ad impasto colorato
Coloured-body fine porcelain stoneware
Feinsteinzeug aus farbiger Masse
Grès cérame fin à pâte colorée

Effetto Pietra
Stone Look
Natursteinoptik
Effet Pierre

Rivestimento
Wall Tiles
Wandfliesen
Revêtement

Pavimento
Floor Tiles
Bodenfliesen
Sol

Ripresa grafica tra le diverse lastre rettificata contenuta entro le tolleranze previste dalla norma. Per un corretto allineamento si consiglia di utilizzare una fuga di 2 mm.
Graphic representation between the rectified tiles is contained within the tolerances provided by the standard. For a correct alignment it is recommended to use a 2 mm joint.
Grafische Darstellung zwischen den verschiedenen rektifizierten Platten innerhalb der in der Norm vorgesehenen Toleranzen. Für eine korrekte Anpassung wird eine Fuge von 2mm empfohlen.
Reproduction graphique entre les différents carreaux rectifiés dans les limites des tolérances prévues par la norme. Pour un alignement correct, il est recommandé d'utiliser joints de 2 mm.

▶ WATCH THE VIDEO

Journey

Otta

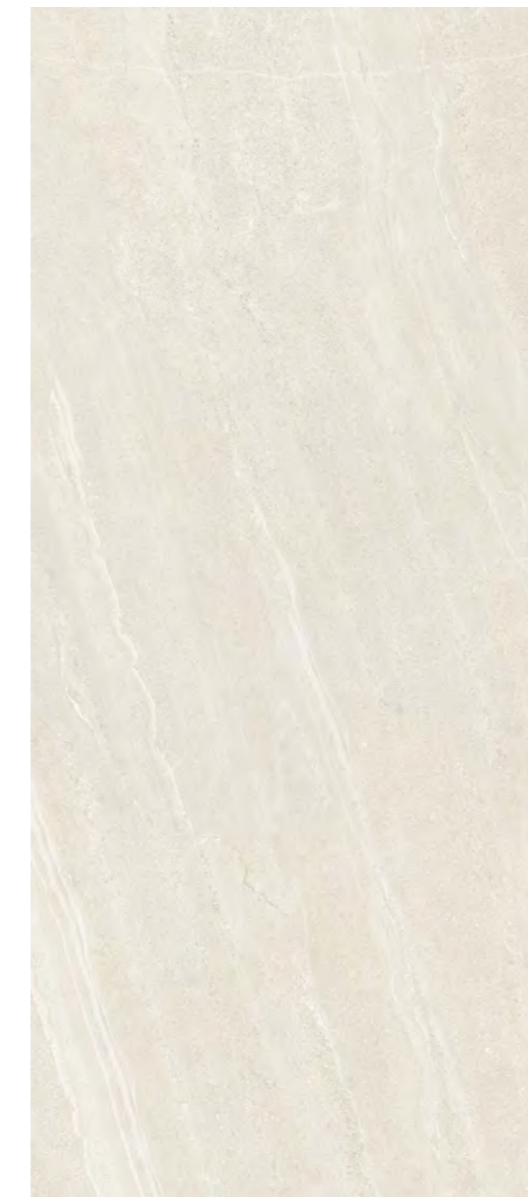

120x280
06232 | Journey Otta Nat/Ret

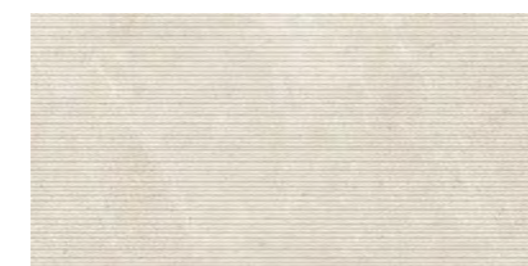

60x120
Synchro Digit Piemme® Technology
04688A | Journey Scratch Otta Nat/Ret



120x120
04953 | Journey Otta Nat/Ret
05299 | Journey Otta Silk/Ret



60x120
04671A | Journey Otta Nat/Ret
04678A | Journey Otta Silk/Ret



60x120
Synchro Digit Piemme® Technology
*04697A | Journey Otta Antislip/Ret



60x120
Synchro Digit Piemme® Technology
04687A | Journey Tetris Warm Nat/Ret

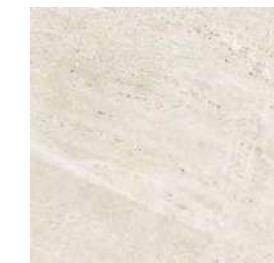

60x60
04717 | Journey Otta Nat/Ret
04722 | Journey Otta Silk/Ret

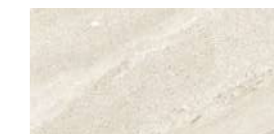

30x60
04726 | Journey Otta Nat/Ret
04731 | Journey Otta Silk/Ret



30x60
04735 | Journey Wave Otta Nat/Ret

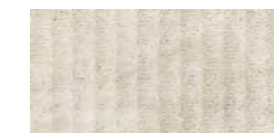

30x60
04739 | Journey Flute Otta Nat/Ret

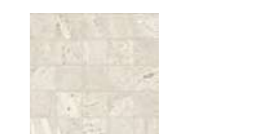

30x30
04937 | Journey Mosaico Otta Nat/Ret

* L'Articolo non ha verso di posa
Item with no laying direction
Artikel ohne Verlegerichtung
Article sans sens de pose

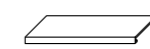
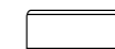



Journey

Stone Effect
PREMIUM

Sarek



120x280
06233 | Journey Sarek Nat/Ret



60x120
Synchro Digit Piemme® Technology
04689A | Journey Scratch Sarek Nat/Ret

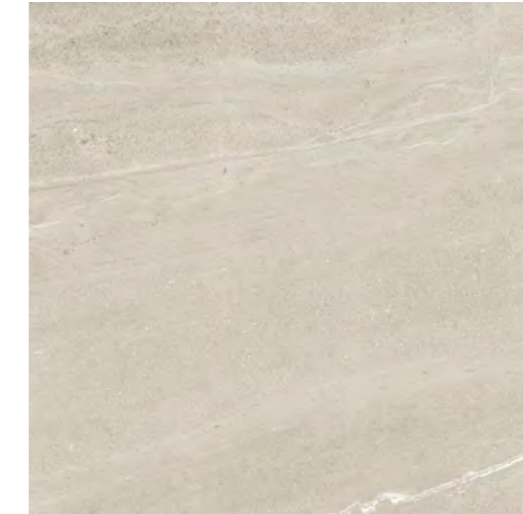

120x120
04954 | Journey Sarek Nat/Ret
05301 | Journey Sarek Silk/Ret



60x120
04673A | Journey Sarek Nat/Ret
04681A | Journey Sarek Silk/Ret



60x120
Synchro Digit Piemme® Technology
***04699A** | Journey Sarek Antislip/Ret



60x120
Synchro Digit Piemme® Technology
04687A | Journey Tetris Warm Nat/Ret



60x60
04718 | Journey Sarek Nat/Ret
04723 | Journey Sarek Silk/Ret



30x60
04727 | Journey Sarek Nat/Ret
04732 | Journey Sarek Silk/Ret



30x60
04736 | Journey Wave Sarek Nat/Ret

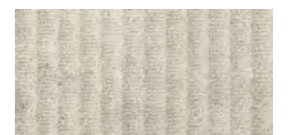

30x60
04741 | Journey Flute Sarek Nat/Ret

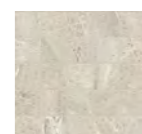

30x30
04938 | Journey Mosaico Sarek Nat/Ret

* L'Articolo non ha verso di posa
Item with no laying direction
Artikel ohne Verlegerichtung
Article sans sens de pose

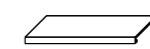
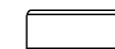

Journey

Cumbria



120x120
04955 | Journey Cumbria Nat/Ret
05302 | Journey Cumbria Silk/Ret



60x60
04719 | Journey Cumbria Nat/Ret
04724 | Journey Cumbria Silk/Ret

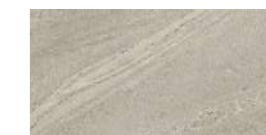

30x60
04728 | Journey Cumbria Nat/Ret
04733 | Journey Cumbria Silk/Ret



60x120
04674A | Journey Cumbria Nat/Ret
04682A | Journey Cumbria Silk/Ret



60x120
Synchro Digit Piemme® Technology
04691A | Journey Scratch Cumbria Nat/Ret



30x60
04737 | Journey Wave Cumbria Nat/Ret



60x120
Synchro Digit Piemme® Technology
*04701A | Journey Cumbria Antislip/Ret



60x120
Synchro Digit Piemme® Technology
04685A | Journey Tetris Cold Nat/Ret

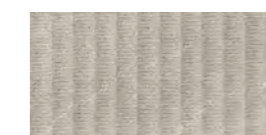

30x60
04742 | Journey Flute Cumbria Nat/Ret



30x30
04939 | Journey Mosaico Cumbria Nat/Ret

* L'Articolo non ha verso di posa
Item with no laying direction
Artikel ohne Verlegerichtung
Article sans sens de pose

Journey

Lomond



120x120

04956 | Journey Lomond Nat/Ret
05303 | Journey Lomond Silk/Ret

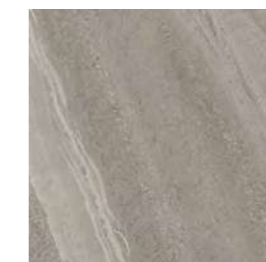

60x60

04721 | Journey Lomond Nat/Ret
04725 | Journey Lomond Silk/Ret



30x60

04729 | Journey Lomond Nat/Ret
04734 | Journey Lomond Silk/Ret



60x120

04676A | Journey Lomond Nat/Ret
04683A | Journey Lomond Silk/Ret



60x120

Synchro Digit Piemme® Technology
04693A | Journey Scratch Lomond Nat/Ret

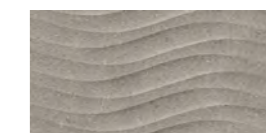

30x60

04738 | Journey Wave Lomond Nat/Ret



60x120

Synchro Digit Piemme® Technology
*04705A | Journey Lomond Antislip/Ret



60x120

Synchro Digit Piemme® Technology
04685A | Journey Tetris Cold Nat/Ret

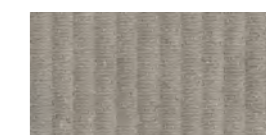

30x60

04743 | Journey Flute Lomond Nat/Ret









30x30

04940 | Journey Mosaico Lomond Nat/Ret

* L'articolo non ha verso di posa
Item with no laying direction
Artikel ohne Verlegerichtung
Article sans sens de pose

Imballi









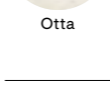

Packing
Verpackung
Emballage

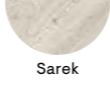
Formati Sizes	± MM	 Pezzi Scatola Pieces/Box Stck/Karton Carreaux/Boite	 Mq/Scatola Sqmt/Box Qm/Karton M2/Boite	 Kg/Scatola Kgs/Box Kg/Karton Kg/Boite	 Scatole/Paletta Boxes/Pallet Karton/Palette Boite/Palette	 Mq/Paletta Sqmt/Pallet Qm/Pallet M2/Palette	 Kg/Paletta Kgs/Pallet Kg/Pallet Kg/Palette	 Formato Paletta Size Pallet Format Pallet Dim. Palette	
120x280 (48"x110") Nat/Ret	P	6,0	1	3,36	46,50	20	67,20	930	143x294x35
120x120 (48"x48") Nat/Ret - Silk/Ret	P	9,5	2	2,880	58,00	22	63,36	1276,00	135x122x68
60x120 (24"x48") Nat/Ret - Silk/Ret - Antislip/Ret (A)	P	9,5	2	1,440	31,00	36	51,84	1116,00	122x95x76
60x120 (24"x48") Nat/Ret Scratch (A)	P	9,5	2	1,440	31,00	36	51,84	1116,00	122x95x76
60x60 (24"x24") Nat/Ret - Silk/Ret	P	9,5	4	1,440	29,00	32	46,08	928,00	120x80x75
30x60 (12"x24") Nat/Ret - Silk/Ret	P	9,5	7	1,260	25,30	40	50,40	1012,00	120x80x75
60x120 (24"x48") Tetris Nat/Ret (A)	P	9,5	2	1,440	31,00	36	51,84	1116,00	122x95x76
30x60 (12"x24") Wave Nat/Ret	P	9,5	7	1,260	26,30	32	40,32	841,60	120x80x75
30x60 (12"x24") Flute Nat/Ret	P	9,5	7	1,260	26,30	32	40,32	841,60	120x80x75
30x30 (12"x12") Mosaico Nat/Ret	P	9,5	5	0,45	8,50	60	-	-	-
Pezzi Speciali / Special Pieces									
33x120 (13"x48") Gradino Costa Retta Nat/Ret - Silk/Ret	P	9,5	2	0,792	18,50	20	-	-	-
4,5x60 (1 1/2"x24") Battiscopa Nat/Ret - Silk/Ret	P	9,5	14	0,378	8,00	80	-	-	-

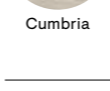
Riepilogo Gamma

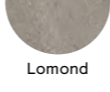
Collection
Serie
Gamme

PDF Merchandising

Formati Sizes	Structure 3D 3D Structures										Pezzi Speciali Special Pieces						
	120x280 48"x110"	120x120 48"x48"	60x120 24"x48"	60x60 24"x24"	30x60 12"x24"	EN 16165C	EN 16165A	DCOF	BS EN 16165: 2021-C	AS 4586 2013	Tetris 60x120 24"x48"	Scratch 60x120 24"x48"	Wave 30x60 12"x24"	Flute 30x60 12"x24"	Mosaico 30x30 12"x12"	Gradino Costa Retta 33x120 13"x48"	Battiscopa 4,5x60 1 1/2"x24"
± 6,0	± 9,5	± 9,5	± 9,5	± 9,5							± 9,5	± 9,5	± 9,5	± 9,5	± 9,5	± 9,5	± 9,5
 Nat/Ret	06232	04953	04671A	04717	04726	R10	B	>0.42	wet, dry >36	P3	04687A	04688A	04735	04739	04937	04941	04929
 Silk/Ret		05299	04678A	04722	04731	V2		>0.42								04945	04933
 Antislip/Ret			04697A			R11	A+B+C	>0.42	wet, dry >36	P4							
 Nat/Ret	06233	04954	04673A	04718	04727	R10	B	>0.42	wet, dry >36	P3	04687A	04689A	04736	04741	04938	04942	04930
 Silk/Ret		05301	04681A	04723	04732	V2		>0.42								04946	04934
 Antislip/Ret			04699A			R11	A+B+C	>0.42	wet, dry >36	P4							
 Nat/Ret		04955	04674A	04719	04728	R10	B	>0.42	wet, dry >36	P3	04685A	04691A	04737	04742	04939	04943	04931
 Silk/Ret		05302	04682A	04724	04733	V2		>0.42								04947	04935
 Antislip/Ret			04701A			R11	A+B+C	>0.42	wet, dry >36	P4							
 Nat/Ret		04956	04676A	04721	04729	R10	B	>0.42	wet, dry >36	P3	04685A	04693A	04738	04743	04940	04944	04932
 Silk/Ret		05303	04683A	04725	04734	V2		>0.42								04948	04936
 Antislip/Ret			04705A			R11	A+B+C	>0.42	wet, dry >36	P4							



Ibla

Ibla è una serie in gres porcellanato di ultima generazione, estremamente ricca nell'assortimento che offre al progettista innumerevoli soluzioni d'utilizzo, tutte perfettamente coordinabili tra loro per realizzare un progetto architettonico di altissimo livello sotto l'aspetto sia tecnico che estetico, coniugando la grande tradizione creativa all'eccellente innovazione tecnologica e produttiva Italiana.

Ibla is a latest-generation porcelain stoneware series with an extremely rich assortment, offering the architect countless potentials for use, all perfectly matchable as the basis for architectural projects with the highest technical and aesthetic values, as a great creative tradition is paired with Italian excellence in technological and production innovation.

Ibla ist eine Feinsteinzeugserie, die dem jüngsten Stand der Technik entspricht. Ihr umfangreiches Sortiment bietet Architekten und Planern zahlreiche, perfekt kombinierbare Lösungen für Architekturprojekte, die technisch und ästhetisch höchste Ansprüche erfüllen, und in denen sich Kreativität mit innovativer Technik und Produktion im Zeichen italienischer Exzellenz verbinden.

Ibla est une série en grès cérame de dernière génération. La grande richesse de son assortiment offre au concepteur d'innombrables solutions d'utilisation, toutes parfaitement coordonnées : c'est l'assurance de pouvoir créer un projet architectural d'un niveau technique et esthétique de haute volée, conjuguant la grande tradition créative avec l'excellence italienne en matière d'innovation, de technologie et de production.

4

Colori
Colours
Farben
Couleurs

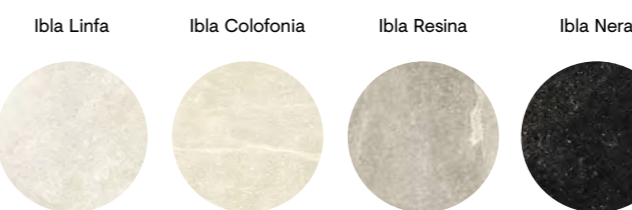

7

Formati
Sizes
Formate
Formats

Ibla Linfa	Ibla Colofonia	Ibla Resina	Ibla Nera
120×280 48"×110"	120×120 48"×48"	60×120 24"×48"	30×120 12"×48"
60×60 24"×24"	10×60 4"×24"	10×53 4"×20"	

3

Superfici
Surfaces
Oberflächen
Surfaces

Naturale Lappato Antislip

1

Strutture 3D
3D structures
Strukturen
Décorations en relief

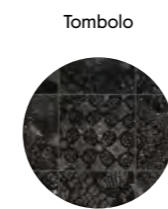

i



Tecnologia - Technology - Technologie:
Synchro Digit Piemme®
Superficie con struttura digitale sincronizzata
Synchronized digital structured surface
Im synchronisierten Digitaldruckverfahren
hergestellte 3D-Oberfläche
Surface avec texture et finition par
impression numérique synchronisée

Gres fine porcellanato ad impasto colorato
Coloured-body fine porcelain stoneware
Feinsteinzeug aus farbiger Masse
Grès cérame fin à pâte colorée

Effetto Pietra
Stone Look
Natursteinoptik
Effet Pierre

Rivestimento
Wall Tiles
Wandfliesen
Revêtement

Pavimento
Floor Tiles
Bodenfliesen
Sol

Ripresa grafica tra le diverse lastre rettificata contenuta entro le tolleranze previste dalla norma. Per un corretto allineamento si consiglia di utilizzare una fuga di 2 mm.
Graphic representation between the rectified tiles is contained within the tolerances provided by the standard. For a correct alignment it is recommended to use a 2 mm joint.
Grafische Darstellung zwischen den verschiedenen rektifizierten Platten innerhalb der in der Norm vorgesehenen Toleranzen. Für eine korrekte Anpassung wird eine Fuge von 2mm empfohlen.
Reproduction graphique entre les différents carreaux rectifiés dans les limites des tolérances prévues par la norme. Pour un alignement correct, il est recommandé d'utiliser joints de 2 mm.

▶ WATCH THE VIDEO

Ibla

Ibla Linfa



120x280
06235 | Ibla Linfa Lap/Ret



120x120
06226 | Ibla Linfa Lap/Ret

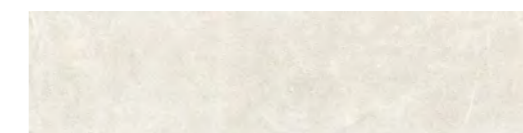

30x120
03992A | Ibla Linfa Nat/Ret
03996A | Ibla Linfa Lap/Ret



60x120
04004B | Ibla Zagara Light Nat/Ret

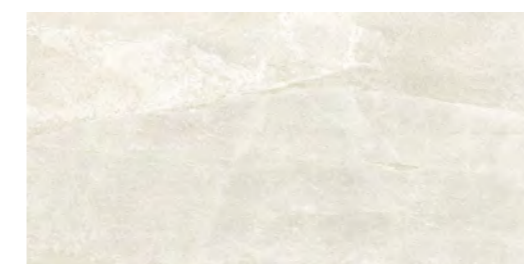

60x120
03976B | Ibla Linfa Nat/Ret
03980B | Ibla Linfa Lap/Ret



60x120
04002B | Ibla Tombolo Light Lap/Ret

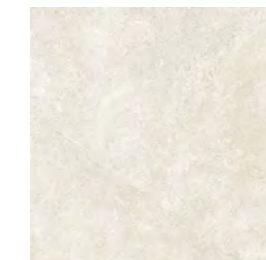

60x60
03984A | Ibla Linfa Nat/Ret
03988A | Ibla Linfa Lap/Ret

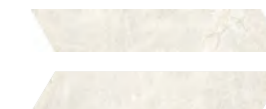

10x53
04016 | Chevron Linfa Nat/Ret
04021 | Chevron Linfa Lap/Ret



10x60
04025 | Listoncino Linfa Nat/Ret
04029 | Listoncino Linfa Lap/Ret



28,2x28,5
04007 | Opus Linfa Mix Lap/Nat



30x30
04012 | Ragusa Linfa Mix Lap/Nat

Ibla

Ibla Colofonia

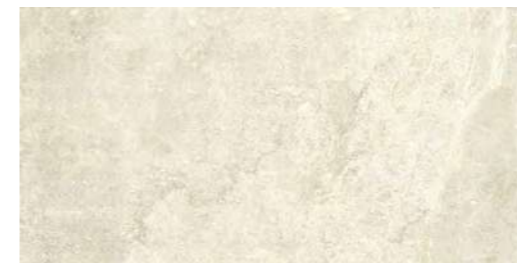

60x120
03977B | Ibla Colofonia Nat/Ret
03981B | Ibla Colofonia Lap/Ret
05273B | Ibla Colofonia Antislip/Ret

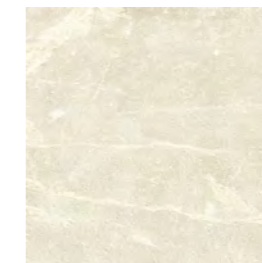

60x60
03985A | Ibla Colofonia Nat/Ret
03989A | Ibla Colofonia Lap/Ret



28,2x28,5
04008 | Opus Colofonia Mix Lap/Nat

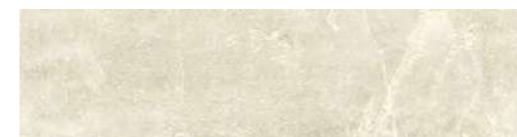

30x120
03993A | Ibla Colofonia Nat/Ret
03997A | Ibla Colofonia Lap/Ret

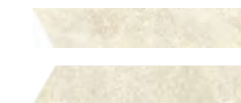

10x53
04017 | Chevron Colofonia Nat/Ret
04022 | Chevron Colofonia Lap/Ret



30x30
04013 | Ragusa Colofonia Mix Lap/Nat



10x60
04026 | Listoncino Colofonia Nat/Ret
04031 | Listoncino Colofonia Lap/Ret



Ibla

Ibla Resina



60x120
03978B | Ibla Resina Nat/Ret
03982B | Ibla Resina Lap/Ret
05274B | Ibla Resina Antislip/Ret



60x60
03986A | Ibla Resina Nat/Ret
03990A | Ibla Resina Lap/Ret



28,2x28,5
04009 | Opus Resina Mix Lap/Nat



30x120
03994A | Ibla Resina Nat/Ret
03998A | Ibla Resina Lap/Ret



10x53
04018 | Chevron Resina Nat/Ret
04023 | Chevron Resina Lap/Ret



30x30
04014 | Ragusa Resina Mix Lap/Nat



60x120
04005B | Ibla Zagara Mid Nat/Ret



10x60
04027 | Listoncino Resina Nat/Ret
04032 | Listoncino Resina Lap/Ret

Ibla

Ibla Nera



120x280
06234 | Ibla Nera Lap/Ret



120x120
06225 | Ibla Nera Lap/Ret

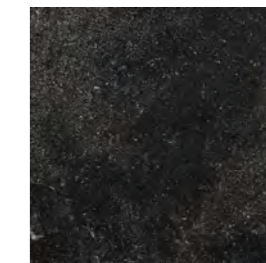

60x60
03983A | Ibla Nera Nat/Ret
03987A | Ibla Nera Lap/Ret



10x53
04015 | Ibla Chevron Nera Nat/Ret
04019 | Ibla Chevron Nera Lap/Ret



30x120
03991A | Ibla Nera Nat/Ret
03995A | Ibla Nera Lap/Ret



10x60
04024 | Listoncino Nera Nat/Ret
04028 | Listoncino Nera Lap/Ret



60x120
04003B | Ibla Zagara Dark Nat/Ret

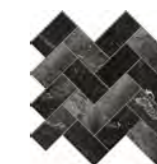

28,2x28,5
04006 | Opus Nera Mix Lap/Nat



60x120
03975B | Ibla Nera Nat/Ret
03979B | Ibla Nera Lap/Ret



60x120
04001B | Ibla Tombolo Dark Lap/Ret



30x30
04011 | Ragusa Nera Mix Lap/Nat

▶ WATCH THE VIDEO

Formati Sizes		± MM	Pezzi Scatola Pieces/Box Stck/Karton Carreaux/Boîte	Mq/Scatola Sqmt/Box Qm/Karton M2/Boîte	Kg/Scatola Kgs/Box Kg/Karton Kg/Boîte	Scatole/Paletta Boxes/Pallet Karton/Palette Boîte/Palette	Mq/Paletta Sqmt/Pallet Qm/Pallet M2/Palette	Kg/Paletta Kgs/Pallet Kg/Pallet Kg/Palette	Formato Paletta Size Pallet Format Pallet Dim. Palette
120×280 (48"×110") Lap/Ret	P	6,0	1	3,36	46,50	20	67,20	930	143x294x35
120×120 (48"×48") Lap/Ret	P	8,5	2	2,88	58,00	24	69,12	1392	135x122x68
60×120 (24"×48") Nat/Ret - Lap/Ret	P	9,5	2	1,44	31,00	36	51,84	1116	122x95x76
30×120 (12"×48") Nat/Ret - Lap/Ret	P	9,5	4	1,44	31,00	36	51,84	1116	122x96x70
60×60 (24"×24") Nat/Ret - Lap/Ret	P	9,5	4	1,44	29,00	32	46,08	928	120x80x75
60×120 (24"×48") Tombolo Lap/Ret	P	9,5	2	1,44	31,00	36	51,84	1116	122x95x76
60×120 (24"×48") Zagara Nat/Ret	P	9,5	2	1,44	31,00	36	51,84	1116	122x95x76
10×60 (4"×24") Listoncino Nat/Ret - Lap/Ret	P	9,5	10	0,60	12,50	72	43,20	900	120×80×75
10×53 (4"×20") Chevron Nat/Ret - Lap/Ret	P	9,5	12	0,636	13,20	60	38,16	792	120×80×75
28,2×28,5 (11"×11¼") Opus Mix Lap/Nat	P	9,5	6	0,482	9,5	60	-	-	-
30×30 (12"×12") Ragusa Mix Lap/Nat	P	9,5	5	0,45	8,5	60	-	-	-
Pezzi Speciali / Special Pieces									
33×120 (13"×48") Gradino Costa Retta Nat/Ret - Lap/Ret	P	9,5	2	0,792	18,50	20	-	-	-
4,5×60 (1½"×24") Battiscopa Nat/Ret - Lap/Ret	P	9,5	14	0,378	8,00	80	-	-	-



Formati Sizes	Formati Sizes												Pezzi Speciali Special Pieces				
	120×280 48"×110"	120×120 48"×48"	60×120 24"×48"	30×120 12"×48"	60×60 24"×24"	Listoncino 10×60 4"×24"	Chevron 10×53 4"×20"	EN 16165C	EN 16165A	DCOF	BS EN 16165: 2021-C	Zagara 60×120 24"×48"	Tombolo 60×120 24"×48"	Opus Mix 28,2×28,5 11"×11¼"	Ragusa Mix 30×30 12"×12"	Gradino Costa Retta 33×120 13"×48"	Battiscopa 4,5×60 1½"×24"
	± 6,0	± 8,5	± 9,5	± 9,5	± 9,5	± 9,5	± 9,5					± 9,5	± 9,5	± 9,5	± 9,5	± 9,5	± 9,5
Ibla Linfa	Nat/Ret		03976B	03992A	03984A	04025	04016	R10	A+B	>0.42	wet, dry >36	04004B				04043A	04034
	Lap/Ret	06235	06226	03980B	03996A	03988A	04029	04021	V3	R9	A	>0.42				04047A	04038
	Lap/Nat												04002B	04007	04012		
Ibla Colofonia	Nat/Ret		03977B	03993A	03985A	04026	04017	R10	A+B	>0.42	wet, dry >36					04044A	04035
	Lap/Ret		03981B	03997A	03989A	04031	04022	R9	A	>0.42						04048A	04039
	Antislip/ Ret		05273B					V3	R11	A+B+C	>0.42	wet, dry >36					
Lap/Nat													04008	04013			
Ibla Resina	Nat/Ret		03978B	03994A	03986A	04027	04018	R10	A+B	>0.42	wet, dry >36	04005B				04045A	04036
	Lap/Ret		03982B	03998A	03990A	04032	04023	R9	A	>0.42						04049A	04041
	Antislip/ Ret		05274B					V3	R11	A+B+C	>0.42	wet, dry >36					
Lap/Nat													04009	04014			
Ibla Nera	Nat/Ret		03975B	03991A	03983A	04024	04015	R10	A+B	>0.42	wet, dry >36	04003B				04042A	04033
	Lap/Ret	06234	06225	03979B	03995A	03987A	04028	04019	V3	R9	A	>0.42		04001B		04046A	04037
	Lap/Nat													04006	04011		



Evoluta

Nasce con Evoluta Synchro Digit Piemme™: la Superficie con Struttura Digitale Sincronizzata Piemme capace di esprimersi in varianti illimitate che innalzano lo standard qualitativo dell'intero settore ceramico. La superficie tridimensionale non è più formata per pressatura ed è quindi libera dai vincoli ripetitivi dei classici stampi per ceramica; inoltre è perfettamente sincronizzata con l'andamento della grafica di superficie.

Evoluta marks the launch of Synchro Digit Piemme™: the Piemme synchronized digital structure surface capable of expressing itself in unlimited variants that raise the quality standard of the entire ceramic industry. The three-dimensional surface is no longer formed by pressing and is therefore not limited by the repetitive constraints of classic ceramic moulds; it is also perfectly synchronized with the surface graphic pattern.

In Evoluta zeigt sich zum ersten Mal Synchro Digit Piemme™, die mit synchronisierter digitaler Struktur Oberfläche Piemme, die durch die Eröffnung unbegrenzter Gestaltungsvarianten den Qualitätsstandard der gesamten Keramikbranche anhebt. Die reliefierte Oberfläche wird nicht mehr durch Pressung erzielt und ist deshalb auch nicht an die Wiederholungsmuster der klassischen Formpressen für Keramik gebunden. Sie ist auch mit den Oberflächengrafiken vollkommen synchronisiert.

Evoluta marque la naissance de Synchro Digit Piemme™, la surface avec structure synchronisée numérique Piemme, dont les variantes illimitées permettent une expression qui vient rehausser les normes de qualité de tout le secteur de la céramique. La surface tridimensionnelle n'étant plus formée par pressage, elle est désormais libérée des contraintes répétitives imposées par les moules pour céramique classiques. Par ailleurs, elle est parfaitement synchronisée avec l'évolution des éléments graphiques de la surface.

5

Colori
Colours
Farben
Couleurs

Modern Beyond Global Cosmopolitan Advanced

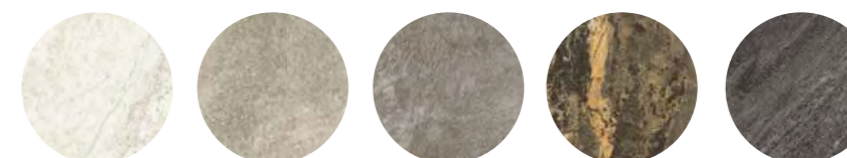

1

Formati
Sizes
Formate
Formats

60×120
24"×48"



3

Superfici
Surfaces
Oberflächen
Surfaces

Naturale Lappato Grip

3

Strutture 3D
3D structures
Strukturen
Décorations en relief

Cave Cluster Forest



i



Tecnologia - Technology - Technologie:
Synchro Digit Piemme™
Superficie con struttura digitale sincronizzata
Synchronized digital structured surface
Im synchronisierten Digitaldruckverfahren
hergestellte 3D-Oberfläche
Surface avec texture et finition par
impression numérique synchronisée

Gres fine porcellanato ad impasto colorato
Coloured-body fine porcelain stoneware
Feinsteinzeug aus farbiger Masse
Grès cérame fin à pâte colorée

Effetto Pietra
Stone Look
Natursteinoptik
Effet Pierre

Rivestimento
Wall Tiles
Wandfliesen
Revêtement

Pavimento
Floor Tiles
Bodenfliesen
Sol

Ripresa grafica tra le diverse lastre rettificata contenuta entro le tolleranze previste dalla norma. Per un corretto allineamento si consiglia di utilizzare una fuga di 2 mm.
Graphic representation between the rectified tiles is contained within the tolerances provided by the standard. For a correct alignment it is recommended to use a 2 mm joint.
Grafische Darstellung zwischen den verschiedenen rektifizierten Platten innerhalb der in der Norm vorgesehenen Toleranzen. Für eine korrekte Anpassung wird eine Fuge von 2mm empfohlen.
Reproduction graphique entre les différents carreaux rectifiés dans les limites des tolérances prévues par la norme. Pour un alignement correct, il est recommandé d'utiliser joints de 2 mm.



Evoluta

Modern

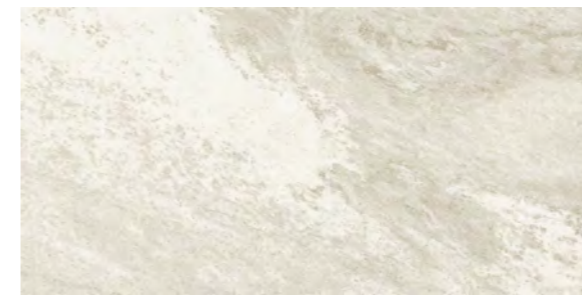

60x120

03544B | Evoluta Modern Nat/Ret
03548B | Evoluta Modern Lap/Ret
03552B | Evoluta Modern Grip/Ret



60x120

03614B | Evoluta Cluster Light Nat/Ret

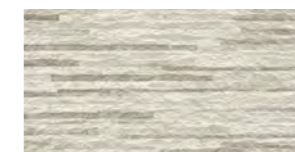

30x60

03609A | Evoluta Cave Light Nat/Ret



60x120

03685B | Evoluta Forest Light Lap/Ret

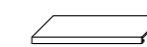
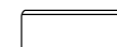



Evoluta

Stone Effect
PREMIUM

Beyond

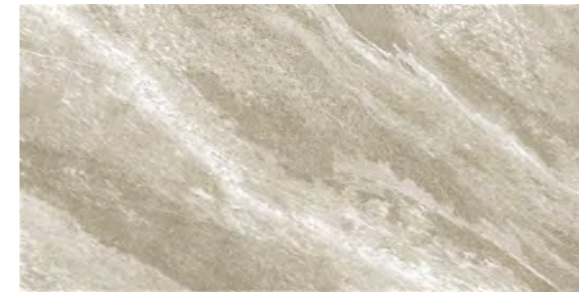

60x120

03596B | Evoluta Beyond Nat/Ret
03597B | Evoluta Beyond Lap/Ret
03598B | Evoluta Beyond Grip/Ret



60x120

03614B | Evoluta Cluster Light Nat/Ret

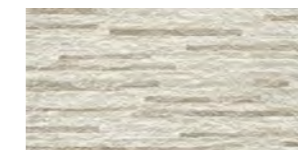

30x60

03609A | Evoluta Cave Light Nat/Ret



60x120

03685B | Evoluta Forest Light Lap/Ret



INDEX

Pezzi speciali
Special pieces

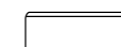

Battiscopa 4,5x60

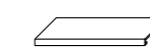

Gradino Costa Retta 33x120



INDEX



Evoluta

Stone Effect
PREMIUM

Global



60x120

03545B | Evoluta Global Nat/Ret
03549B | Evoluta Global Lap/Ret
03553B | Evoluta Global Grip/Ret



60x120

03613B | Evoluta Cluster Dark Nat/Ret

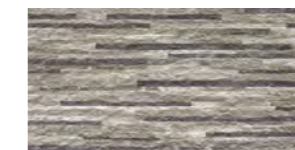

30x60

03608A | Evoluta Cave Dark Nat/Ret



60x120

03612B | Evoluta Forest Lap/Ret

Evoluta

Cosmopolitan



60x120

03546B | Evoluta Cosmopolitan Nat/Ret
03550B | Evoluta Cosmopolitan Lap/Ret
03554B | Evoluta Cosmopolitan Grip/Ret



60x120

03615B | Evoluta Cluster Multicolor Nat/Ret



30x60

03611A | Evoluta Cave Multicolor Nat/Ret

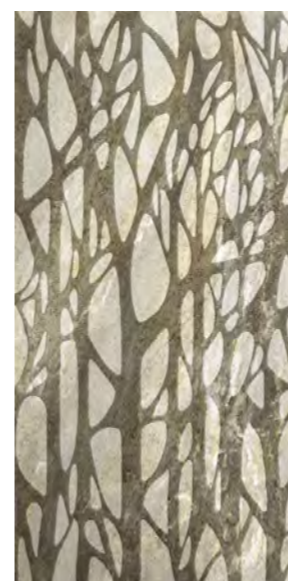

60x120

03612B | Evoluta Forest Lap/Ret



Evoluta

Advanced

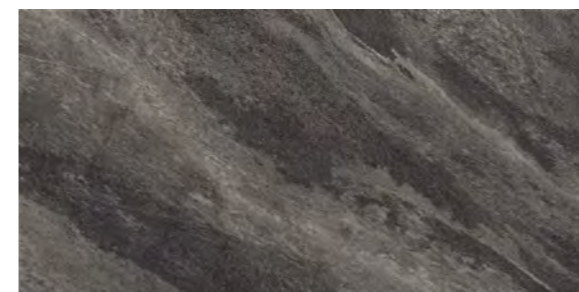

60x120

03543B | Evoluta Advanced Nat/Ret
03547B | Evoluta Advanced Lap/Ret
03551B | Evoluta Advanced Grip/Ret



60x120

03613B | Evoluta Cluster Dark Nat/Ret

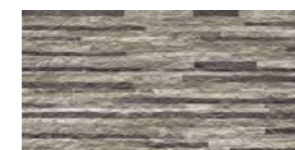

30x60

03608A | Evoluta Cave Dark Nat/Ret



60x120

03612B | Evoluta Forest Lap/Ret

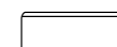

Formato / Size		± MM	Pezzi Scatola Pieces/Box Stck/Karton Carreaux/Boîte	Mq/Scatola Sqmt/Box Qm/Karton M2/Boîte	Kg/Scatola Kgs/Box Kg/Karton Kg/Boîte	Scatole/Paletta Boxes/Pallet Karton/Palette Boîte/Palette	Mq/Paletta Sqmt/Pallet Qm/Pallet M2/Palette	Kg/Paletta Kgs/Pallet Kg/Pallet Kg/Palette	Formato Paletta Size Pallet Format Pallet Dim. Palette
60x120 (24"x48") Nat/Ret	P	9,5	2	1,44	31,00	36	51,84	1116	122x95x76
60x120 (24"x48") Lap/Ret	P	9,5	2	1,44	31,00	36	51,84	1116	122x95x76
60x120 (24"x48") Grip/Ret	P	9,5	2	1,44	31,00	36	51,84	1116	122x95x76
60x120 (24"x48") Forest Lap/Ret	P	9,5	2	1,44	31,00	36	51,84	1116	122x95x76
60x120 (24"x48") Cluster Nat/Ret	P	9,5	2	1,44	31,00	36	51,84	1116	122x95x76
30x60 (12"x24") Cave Nat/Ret	P	9,5	7	1,26	25,30	32	40,32	809,6	120x80x75
Pezzi Speciali / Special Pieces									
33x120 (13"x48") Gradino Costa Retta Nat/Ret - Lap/Ret	P	9,5	2	0,792	18,50	20	-	-	-
4,5x60 (1 1/4"x24") Battiscopa Nat/Ret - Lap/Ret	P	9,5	14	0,378	8,00	80	-	-	-
1,5x120 (3/4"x48") Bacchetta Jolly Nat/Ret - Lap/Ret	P	9,5	6	0,108	2,50	48	-	-	-
1,5x1,5 (3/4"x3/4") Unghia Jolly Nat/Ret - Lap/Ret	P	9,5	6	0,001	0,50	48	-	-	-



Formati Sizes	EN 16165: 2021-C				Strutture 3D 3D Structures				Pezzi Speciali Special Pieces			
	EN 16165C	EN 16165A	DCOF	BS EN 16165: 2021-C	Cluster 60x120 24"x48"	Forest Light 60x120 24"x48"	Forest 60x120 24"x48"	Cave 30x60 12"x24"	Gradino Costa Retta 33x120 13"x48"	Battiscopa 4,5x60 1 1/4"x24"		
± 9,5					± 9,5	± 9,5	± 9,5	± 9,5	± 9,5	± 9,5		
Modern	Nat/Ret	03544B	V3	R10	A+B	>0,42	wet, dry >36	03614B		03609A	03564A	03556
	Lap/Ret	03548B				0,42			03685B		03568A	03560
	Grip/Ret	03552B		R11	A+B+C	>0,42	wet, dry >36					
Beyond	Nat/Ret	03596B	V3	R10	A+B	>0,42	wet, dry >36	03614B		03609A	03602A	03599
	Lap/Ret	03597B				0,42			03685B		03603A	03601
	Grip/Ret	03598B		R11	A+B+C	>0,42	wet, dry >36					
Global	Nat/Ret	03545B	V3	R10	A+B	>0,42	wet, dry >36	03613B		03608A	03565A	03557
	Lap/Ret	03549B				0,42				03612B	03569A	03561
	Grip/Ret	03553B		R11	A+B+C	>0,42	wet, dry >36					
Cosmopolitan	Nat/Ret	03546B	V4	R10	A+B	>0,42	wet, dry >36	03615B		03611A	03566A	03558
	Lap/Ret	03550B				0,42				03612B	03570A	03562
	Grip/Ret	03554B		R11	A+B+C	>0,42	wet, dry >36					
Advanced	Nat/Ret	03543B	V3	R10	A+B	>0,42	wet, dry >36	03613B		03608A	03563A	03555
	Lap/Ret	03547B				0,42				03612B	03567A	03559
	Grip/Ret	03551B		R11	A+B+C	>0,42	wet, dry >36					

Unigestone

Unigestone: una collezione ispirata all'estetica di pietre, graniti e marmi differenti, sapientemente miscelati tra di loro, per muovere con carattere lo stile di ogni ambiente, residenziale o commerciale.

Unigestone: a collection inspired by the aesthetics of different stones, granites and marbles, skilfully mixed together to move with character. The style of every environment, whether residential or commercial.

Unigestone: eine am aussehen verschiedener und auf gelungene weise miteinander kombinierter steine, granite und marmorarten inspirierte kollektion. Bringt stilvoll bewegung und charakter in jeden gewerbe- oder wohnraum.

Unigestone: une collection qui puise son inspiration a l'esthetique de la pierre. Plusieurs types de granits et de marbres savamment melanges apportent une note authentique de caractere a tout espace de vic, a usage privatif ou commercial.

5

Colori
Colours
Farben
Couleurs

Silk

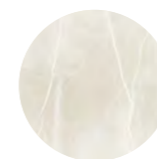

Sand



Silver



Titanium

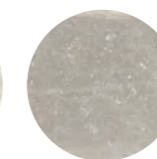

Nite

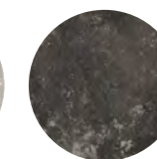

6

Formati
Sizes
Formate
Formats

120×120
48"×48"



60×120
24"×48"



80×80
31½"×31½"



60×60
24"×24"



30×60
12"×24"



10×53
4"×20"



1

Superfici
Surfaces
Oberflächen
Surfaces

Naturale

i

Effetto Pietra
Stone Look
Natursteinoptik
Effet Pierre

Rivestimento
Wall Tiles
Wandfliesen
Revêtement

Pavimento
Floor Tiles
Bodenfliesen
Sol

Gres fine porcellanato ad impasto colorato
Coloured-body fine porcelain stoneware
Feinsteinzeug aus farbiger Masse
Grès cérame fin à pâte colorée

Tecnologia digitale
Digital technology
Digital Technologie
Technologie numérique

Ripresa grafica tra le diverse lastre rettificata contenuta entro le tolleranze previste dalla norma. Per un corretto allineamento si consiglia di utilizzare una fuga di 2 mm.
Graphic representation between the rectified tiles is contained within the tolerances provided by the standard. For a correct alignment it is recommended to use a 2 mm joint.
Grafische Darstellung zwischen den verschiedenen rektifizierten Platten innerhalb der in der Norm vorgesehenen Toleranzen. Für eine korrekte Anpassung wird eine Fuge von 2mm empfohlen.
Reproduction graphique entre les différents carreaux rectifiés dans les limites des tolérances prévues par la norme. Pour un alignement correct, il est recommandé d'utiliser joints de 2 mm.

WATCH THE VIDEO

Unigestone

Silk



120x120
05295 | Unique Silk Nat/Ret

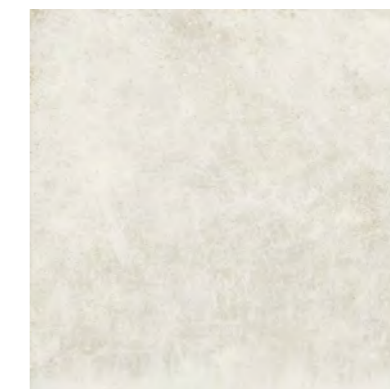

80x80
03639 | Unique Silk Nat/Ret

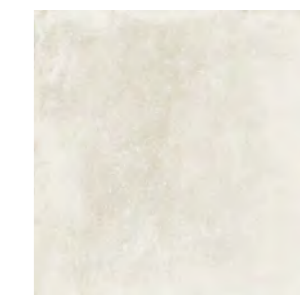

60x60
01702A | Unique Silk Nat/Ret

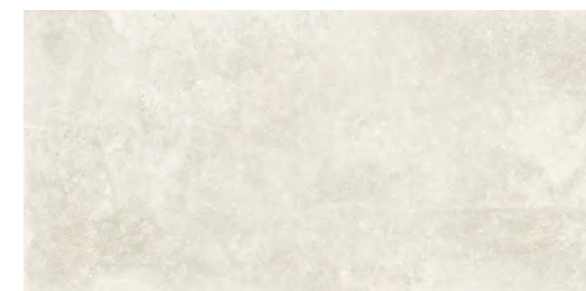

60x120
02995B | Unique Silk Nat/Ret



30x60
01707A | Unique Silk Nat/Ret

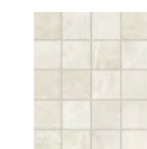

30x30
01771 | Unique Silk Mosaico Nat/Ret

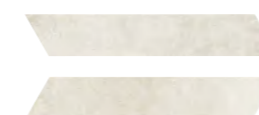

10x53
01792 | Unique Silk Chevron Nat/Ret



Unigestone

Sand



120x120
05296 | Unique Sand Nat/Ret



80x80
03684 | Unique Sand Nat/Ret

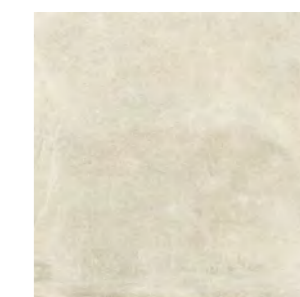

60x60
01703A | Unique Sand Nat/Ret



60x120
02996B | Unique Sand Nat/Ret



30x60
01708A | Unique Sand Nat/Ret

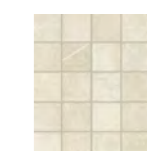

30x30
01772 | Unique Sand Mosaico Nat/Ret

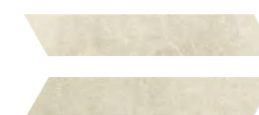

10x53
01793 | Unique Sand Chevron Nat/Ret

Unigestone

Silver

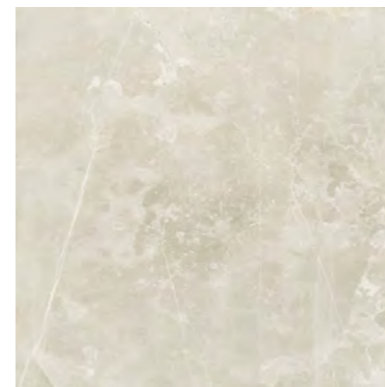

80x80
03642 | Unique Silver Nat/Ret

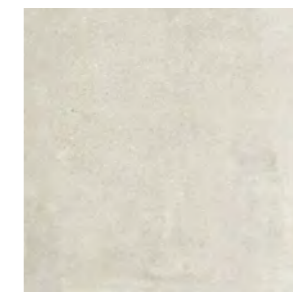

60x60
01704A | Unique Silver Nat/Ret



60x120
02997B | Unique Silver Nat/Ret



30x60
01709A | Unique Silver Nat/Ret

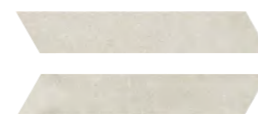

10x53
01794 | Unique Silver Chevron Nat/Ret

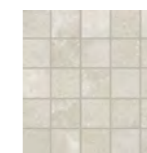

30x30
01773 | Unique Silver Mosaico Nat/Ret



Unigestone

Titanium

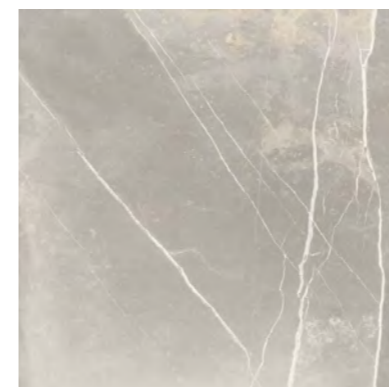

80x80
03637 | Unique Titanium Nat/Ret

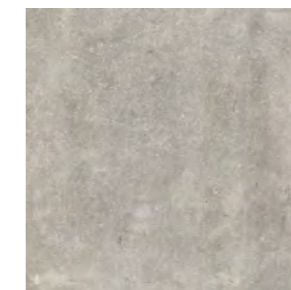

60x60
01705A | Unique Titanium Nat/Ret



60x120
02976A | Unique Titanium Nat/Ret



30x60
01711A | Unique Titanium Nat/Ret



10x53
01795 | Unique Titanium Chevron Nat/Ret

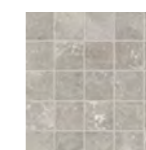

30x30
01774 | Unique Titanium Mosaico Nat/Ret





Nite



120x120
05297 | Unique Nite Nat/Ret



80x80
03617 | Unique Nite Nat/Ret



60x60
01706A | Unique Nite Nat/Ret



60x120
02998A | Unique Nite Nat/Ret



30x60
01712A | Unique Nite Nat/Ret



30x30
01775 | Unique Nite Mosaico Nat/Ret



10x53
01796 | Unique Nite Chevron Nat/Ret

Imballi

Packing
Verpackung
Emballage

Formato / Size		± MM	Pezzi Scatola Pcs/Box Stck/Karton Carreaux/Boîtes	Mq/Scatola Sqmt/Box M2/Karton Qm/Boîtes	Kg/Scatola Kgs/Box Kg/Karton Kg/Boîtes	Scatola/Paletta Boxes/Pallet Karton/Palette Boîtes/Pallet	Mq/Paletta Sqmt/Pallet M2/Palette Qm/Pallet	Kg/Paletta Kgs/Pallet Kg/Palette Kg/Pallet	Formato Paletta Size Pallet Format Palette Dim. Palette
120×120 (48"×48") Nat/Ret	P	9,5	2	2,88	58,00	22	63,36	1276	135×122×68
60×120 (24"×48") Nat/Ret (B)	P	9,5	2	1,44	31,00	36	51,84	1116	122×95×76
60×120 (24"×48") Nat/Ret (A)	P	9,5	2	1,44	31,00	30	43,20	930	122×82×75
80×80 (31½"×31½") Nat/Ret	P	9,5	2	1,280	27,50	50	64,00	1375	122×80×96
60×60 (24"×24") Nat/Ret	P	9,5	4	1,44	29,00	32	46,08	928	120×80×75
30×60 (12"×24") Nat/Ret	P	9,5	7	1,26	25,30	40	50,40	1012	120×80×75
10×53 (4"×20") Chevron Nat/Ret	P	9,5	12	0,636	13,20	60	38,16	792	120×80×75
30×30 (12"×12") Mosaico Nat/Ret	P	9,5	5	0,450	8,50	60	-	-	-
33×120 (13"×48") Gradino costa retta Nat/Ret	P	9,5	2	0,792	18,50	20	-	-	-
8×60 (3½"×24") Battiscopa Nat/Ret	P	9,5	10	0,480	11,00	72	-	-	-
8×80 (3½"×31½") Battiscopa Nat/Ret	P	9,5	7	0,450	11,00	65	-	-	-
6,5×120 (2½"×48") Battiscopa Nat/Ret - Lev/Ret	P	9,5	8	0,624	14,00	48	-	-	-

Riepilogo Gamma

Collection
Serie
Gamme

Formati Sizes											Mosaico 30×30 12"×12"	Pezzi Speciali Special Pieces			
	120×120 48"×48"	60×120 24"×48"	80×80 31½"×31½"	60×60 24"×24"	30×60 12"×24"	Chevron 10×53 4"×20"	EN 16165C	EN 16165A	DCOF	Gradino Costa Retta 33×120 13"×48"		Battiscopa 6,5×120 2½"×48"	Battiscopa 8×80 3½"×31½"	Battiscopa 8×60 3½"×24"	
	± 9,5	± 9,5	± 9,5	± 9,5	± 9,5	± 9,5					± 9,5	± 9,5	± 9,5	± 9,5	
Silk Nat/Ret	05295	02995B	03639	01702A	01707A	01792	V3	R10	A+B	>0.42	01771	03733A	01797	01808	01819
Sand Nat/Ret	05296	02996B	03684	01703A	01708A	01793	V3	R10	A+B	>0.42	01772	03734A	01798	01809	01821
Silver Nat/Ret		02997B	03642	01704A	01709A	01794	V3	R10	A+B	>0.42	01773	03735A	01799	01811	01822
Titanium Nat/Ret		02976A	03637	01705A	01711A	01795	V3	R10	A+B	>0.42	01774	03736A	01801	01812	01823
Nite Nat/Ret	05297	02998A	03617	01706A	01712A	01796	V3	R10	A+B	>0.42	01775	03737A	01802	01813	01824

Bits&Pieces

Designed by Gordon Guillaumier

L'arte del decoro della Roma Antica, dell'"opus incertum e del lapis porphyrites", sono reinterpretati secondo le tecnologie contemporanee, mantenendo intatto il fascino del riuso esaltato nella serialità dell'industria.

The art of decoration of ancient Rome, of the "opus incertum and lapis porphyrites", are reinterpreted according to contemporary technologies, maintaining intact the charm of reuse exalted in industrial mass production.

Die Verzierungskunst des Alten Roms, des "Opus incertum und Lapis porphyrites", den zeitgenössischen Technologien entsprechend neu interpretiert, unter Beibehaltung der Magie einer überschwänglichen Wiederverwendung in der Serienmäßigkeit der Industrie.

L'art de la décoration de la Rome antique, de l'"opus incertum et du lapis porphyrites", a été réinterprété selon les technologies modernes, en préservant le charme du recyclage dans la sérialité de l'industrie.

5

Colori
Colours
Farben
Couleurs



3

Formati
Sizes
Formate
Formats

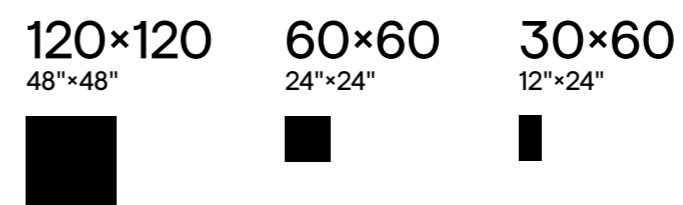

2

Superfici
Surfaces
Oberflächen
Surfaces

Naturale Antislip

1

Strutture 3D
3D structures
Strukturen
Decorations and relief

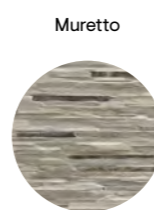

i

Effetto Pietra Stone Look Natursteinoptik Effet Pierre	Rivestimento Wall Tiles Wandfliesen Revêtement	Pavimento Floor Tiles Bodenfliesen Sol	Gres fine porcellanato ad impasto colorato Coloured-body fine porcelain stoneware Feinsteinzeug aus farbiger Masse Grès cérame fin à pâte colorée	Tecnologia digitale Digital technology Digital Technologie Technologie numérique
---	---	---	--	---



WATCH THE VIDEO

Bits&Pieces

Powder Bone



120x120
03403A | Powder Bone Nat/Ret

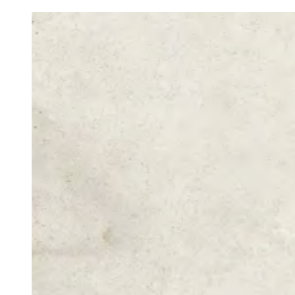

60x60
01157A | Powder Bone Nat/Ret



60x60
01162A | Powder Bone Facet Nat/Ret

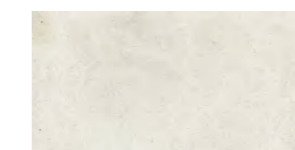

30x60
01205A | Powder Bone Nat/Ret
01222A | Powder Bone Antislip Ret



30x60
01210A | Powder Bone Facet Nat/Ret



30x60
01274A | Bits Muretto Cold Ret

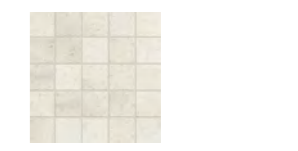

30x30
01276 | Powder Bone Mosaico Nat/Ret

Pearl Gray



120x120
03404A | Pearl Gray Nat/Ret

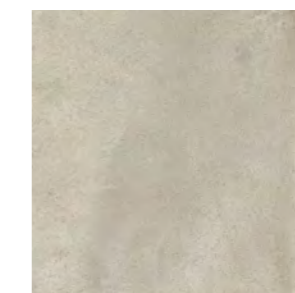

60x60
01159A | Pearl Gray Nat/Ret



60x60
01164A | Pearl Gray Quad Nat/Ret



30x60
01207A | Pearl Gray Nat/Ret
01224A | Pearl Gray Antislip Ret



30x60
01212A | Pearl Gray Quad Nat/Ret

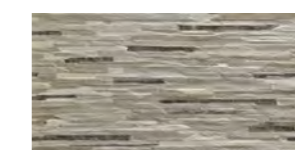

30x60
01274A | Bits Muretto Cold Ret

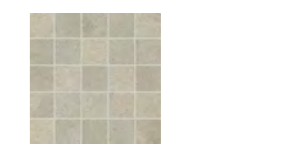

30x30
01278 | Pearl Gray Mosaico Nat/Ret



Pewter Smoke



120x120
03405A | Pewter Smoke Nat/Ret



60x60
01158A | Pewter Smoke Nat/Ret



30x60
01206A | Pewter Smoke Nat/Ret
01223A | Pewter Smoke Antislip Ret

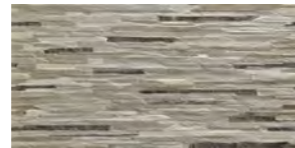

30x60
01274A | Bits Muretto Cold Ret



60x60
01163A | Pewter Smoke Facet Nat/Ret



30x60
01211A | Pewter Smoke Facet Nat/Ret

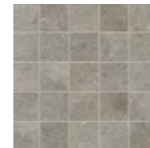

30x30
01277 | Pewter Smoke Mosaico Nat/Ret

Peat Brown

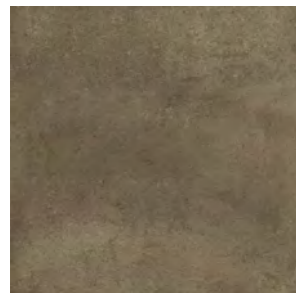

60x60
01160A | Peat Brown Nat/Ret

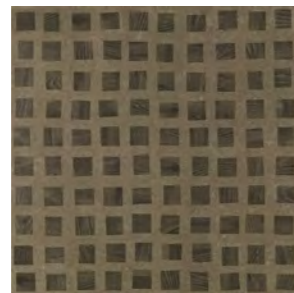

60x60
01165A | Peat Brown Quad Nat/Ret



30x60
01275A | Muretto Warm Ret



30x60
01208A | Peat Brown Nat/Ret
01225A | Peat Brown Antislip Ret



30x60
01213A | Peat Brown Quad Nat/Ret

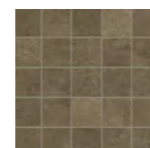

30x30
01279 | Peat Brown Mosaico Nat/Ret

Pitch Black



60x60
01161A | Pitch Black Nat/Ret



30x60
01209A | Pitch Black Nat/Ret
01226A | Pitch Black Antislip Ret

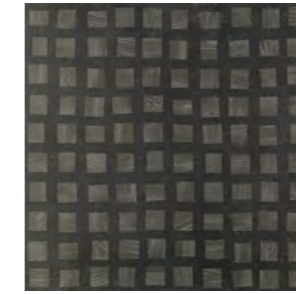

60x60
01166A | Pitch Black Quad Nat/Ret

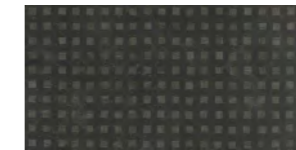

30x60
01214A | Pitch Black Quad Nat/Ret

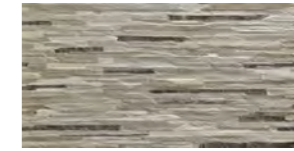

30x60
01274A | Bits Muretto Cold Ret

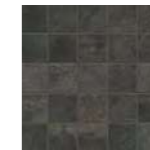

30x30
01281 | Pitch Black Mosaico Nat/Ret

Imballi

Packing
Verpackung
Emballage

Formato / Size		MM	Pezzi/Scatola Pieces/Box Stck/Karton Carreaux/Boîte	Mq/Scatola Sqmt/Box Qm/Karton M2/Boîte	Kg/Scatola Kgs/Box Kg/Karton Kg/Boîte	Scatole/Paletta Boxes/Pallet Karton/Pallet Boite/Palette	Mq/Paletta Sqmt/Pallet Qm/Pallet M2 /Palette	Kg/Paletta Kgs/Pallet Kg/Pallet Kg/Palette	Formato Paletta Size Pallet Format Pallet Dim. Palette
120x120 Nat/Ret	P	9,5	2	2,88	58	22	63,36	1276	135x122x68
60x60 Nat/Ret	P	9,5	4	1,44	29	32	46,08	928	120x80x75
30x60 Nat/Ret	P	9,5	7	1,26	25,30	40	50,40	1012	120x80x75
30x60 Antislip/Ret	P	9,5	7	1,26	25,30	40	50,40	1012	120x80x75
30x60 Muretto	P	9,5	7	1,26	25,30	32	40,32	809,6	120x80x75
60x60 Quad Nat/Ret	P	9,5	4	1,44	29	32	46,08	928	120x80x75
60x60 Facet Nat/Ret	P	9,5	4	1,44	29	32	46,08	928	120x80x75
30x60 Quad Nat/Ret	P	9,5	7	1,26	25,30	40	50,40	1012	120x80x75
30x60 Facet Nat/Ret	P	9,5	7	1,26	25,30	40	50,40	1012	120x80x75
30x30 Mosaico (Su Rete)	P	9,5	5	0,45	8,5	60			
Pezzi Speciali / Special Pieces									
6,5x120 Battiscopa	P	9,5	8	0,624	14	48			
8x60 Battiscopa	P	9,5	10	0,48	11	72			
30x60 Step	P	9,5	6	1,08	22	36			

Riepilogo Gamma

Collection
Serie
Gamme

Formati Sizes								
	120*120 48"*48"	60*60 24"*24"	30*60 12"*24"	EN 16165C	EN 16165A	DCOF		
 Powder Bone	Nat/Ret	03403A	01157A	01205A	V2	R10	A+B	> 0,42
	Antislip			01222A		R11		> 0,42
 Pearl Gray	Nat/Ret	03404A	01159A	01207A	V2	R10	A+B	> 0,42
	Antislip			01224A		R11		> 0,42
 Pewter Smoke	Nat/Ret	03405A	01158A	01206A	V2	R10	A+B	> 0,42
	Antislip			01223A		R11		> 0,42
 Peat Brown	Nat/Ret		01160A	01208A	V2	R10	A+B	> 0,42
	Antislip			01225A		R11		> 0,42
 Pitch Black	Nat/Ret		01161A	01209A	V2	R10	A+B	> 0,42
	Antislip			01226A		R11		> 0,42

Riepilogo Gamma

Collection
Serie
Gamme

Formati Sizes	Strutture 3D 3D Structures							Pezzi Speciali Special Pieces			
	Muretto Cold 30*60 12"*24"	Muretto Warm 30*60 12"*24"	Mosaico 30*30 (Su Rete) 12"*12" (2"*2" Dot)	Quad 60*60 24"*24"	Quad 30*60 12"*24"	Facet 60*60 24"*24"	Facet 30*60 12"*24"	Battiscopa 6,5*120 2½"*48"	Battiscopa 8*60 3¼"*24"	Step 30*60 12"*24"	
 Powder Bone	Nat/Ret	01274A	01275A	01276			01162A	01210A	01401	01248	01259
	Nat/Ret	01274A		01278	01164A	01212A			01402	01251	01262
 Pewter Smoke	Nat/Ret	01274A		01277			01163A	01211A	01403	01249	01261
	Nat/Ret		01275A	01279	01165A	01213A				01252	01263
 Pitch Black	Nat/Ret	01274A		01281	01166A	01214A				01253	01264

Geostone

Da un'attenta ricerca di design nasce Geostone. Il fascino senza tempo delle rocce sedimentarie è riproposto in un blend armonizzato sulla superficie del grès porcellanato Piemme.

Geostone was created on the basis of careful research into design. The timeless appeal of sedimentary rocks is re-presented in a harmonized blend on the surfaces of Piemme porcelain stoneware.

Aus einer sorgfältigen Designstudie entsteht Geostone. Zeitlose Magie des Sedimentgesteins, an der Oberfläche des Feinsteinzeugs von Piemme mit harmonisch abgestimmtem Blend nachempfunden.

Geostone est issue d'une recherche de design attentive; la fascination intemporelle des roches sédimentaires a été revisitée en un mélange harmonieux sur la surface du grès cérame Piemme.

5

Colori
Colours
Farben
Couleurs

Bianco



Beige



Tortora



Terra



Grigio



3

Formati
Sizes
Formate
Formats

60×120
24"×48"



60×60
24"×24"



30×60
12"×24"



3

Superfici
Surfaces
Oberflächen
Surfaces

Naturale

Levigato

Velvet

2

Strutture 3D
3D structures
Strukturen
Decorations and relief

Esagonetta



Velvet



i

Effetto Pietra
Stone Look
Natursteinoptik
Effet Pierre

Rivestimento
Wall Tiles
Wandfliesen
Revêtement

Pavimento
Floor Tiles
Bodenfliesen
Sol

Gres fine porcellanato ad impasto colorato
Coloured-body fine porcelain stoneware
Feinsteinzeug aus farbiger Masse
Grès cérame fin à pâte colorée

Tecnologia digitale
Digital technology
Digital Technologie
Technologie numérique



Geostone

Bianco

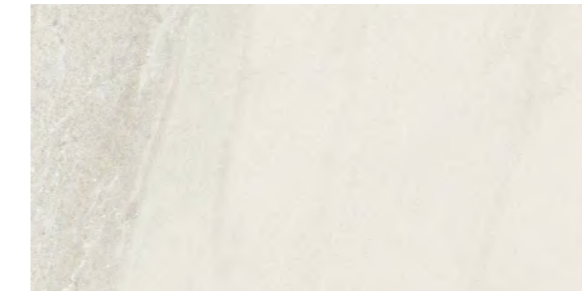

60x120
03053B | Geostone Bianco Nat/Ret
03057C | Geostone Bianco Lev/Ret

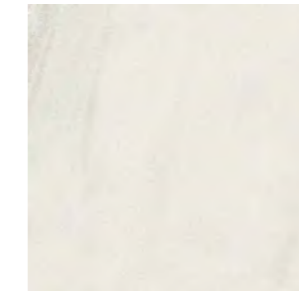

60x60
62150A | Geostone Bianco Nat/Ret



30x60
63550A | Geo Velvet Bianco Grip/Ret

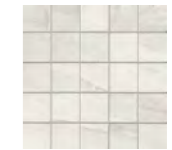

30x30
63650 | Geo Mosaico Bianco Nat/Ret



30x60
62750A | Geostone Bianco Nat/Ret



30x60
63600A | Geo Esagonetta Bianco Nat/Ret

Beige



60x120
03054B | Geostone Beige Nat/Ret
03058C | Geostone Beige Lev/Ret

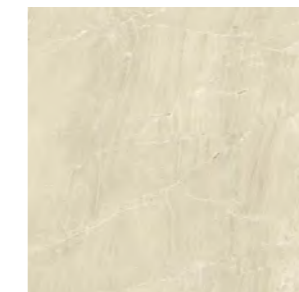

60x60
62170A | Geostone Beige Nat/Ret



30x60
63570A | Geo Velvet Beige Grip/Ret



30x30
64860 | Geo Mosaico Beige Nat/Ret

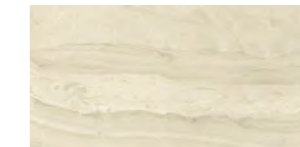

30x60
62780A | Geostone Beige Nat/Ret

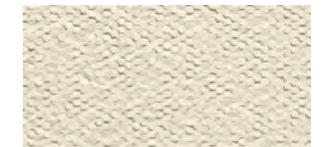

30x60
63620A | Geo Esagonetta Beige Nat/Ret

Tortora

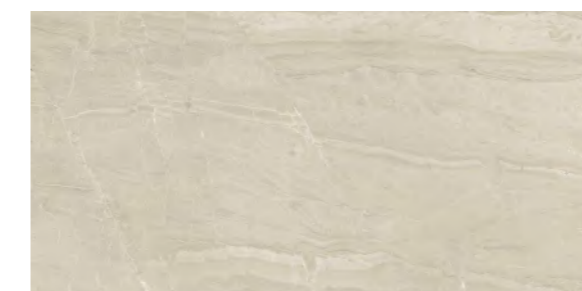

60x120
03056B | Geostone Tortora Nat/Ret
03061C | Geostone Tortora Lev/Ret

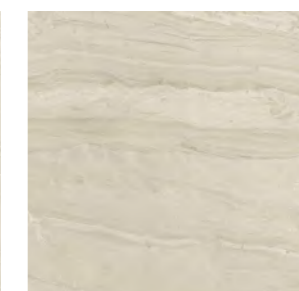

60x60
62190A | Geostone Tortora Nat/Ret

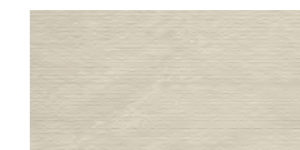

30x60
63590A | Geo Velvet Tortora Grip/Ret

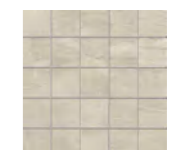

30x30
65680 | Geo Mosaico Tortora Nat/Ret



30x60
62840A | Geostone Tortora Nat/Ret



30x60
63640A | Geo Esagonetta Tortora Nat/Ret

Grigio



60x120
03055A | Geostone Grigio Nat/Ret
03059C | Geostone Grigio Lev/Ret

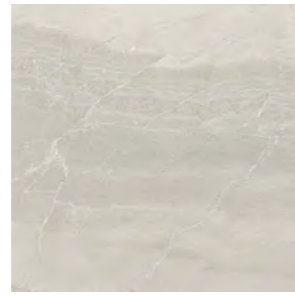

60x60
62160A | Geostone Grigio Nat/Ret

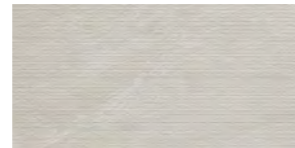

30x60
63560A | Geo Velvet Grigio Grip/Ret



30x30
63660 | Geo Mosaico Grigio Nat/Ret



30x60
62770A | Geostone Grigio Nat/Ret



30x60
63610A | Geo Esagonetta Grigio Nat/Ret

Terra



60x60
62180A | Geostone Terra Nat/Ret



30x60
62810A | Geostone Terra Nat/Ret



30x60
63580A | Geo Velvet Terra Grip/Ret

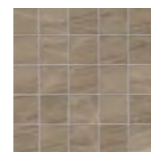

30x30
64870 | Geo Mosaico Terra Nat/Ret

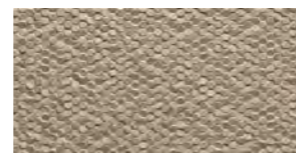

30x60
63630A | Geo Esagonetta Terra Nat/Ret

Imballi

Packing
Verpackung
Emballage

Formato / Size		± MM	Pezzi/Scatola Pieces/Box Stck/Karton Carreaux/Boîte	Mq/Scatola Sqmt/Box Qm/Karton M2/Boîte	Kg/Scatola Kgs/Box Kg/Karton Kg/Boîte	Scatole/Paletta Boxes/Pallet Karton/Pallet Boîte/Palette	Mq/Paletta Sqmt/Pallet Qm/Pallet M2 /Palette	Kg/Paletta Kgs/Pallet Kg/Pallet Kg/Palette	Formato Paletta Size Pallet Format Pallet Dim. Palette
60x120 Nat/Ret (A)	P	9,5	2	1,44	31,0	30	43,20	930	122x82x75
60x120 Nat/Ret (B)	P	9,5	2	1,44	31,0	36	51,84	1116	122x95x76
60x120 Lev/Ret (C)	P	8,5	2	1,44	28,0	44	63,36	1232	122x100x76
60x60 Nat/Ret	P	9,5	4	1,44	29	32	46,08	928	120x80x75
30x60 Nat/Ret	P	9,5	7	1,26	25,30	40	50,40	1012	120x80x75
30x60 Velvet Grip/Ret	P	9,5	7	1,26	25,30	40	50,40	1012	120x80x75
30x60 Esagonetta Ret	P	9,5	7	1,26	25,30	32	40,32	809,6	120x80x75
30x30 Mosaico (Su Rete)	P	9,5	5	0,45	8,5	60			
Pezzi Speciali / Special Pieces									
8x60 Battiscopa	P	9,5	10	0,48	11	72			



Riepilogo Gamma

Collection
Serie
Gamme

Formati Sizes	Formati Sizes				UPEC			Strutture 3D 3D Structures		Decor Decors	Pezzi Speciali Special Pieces	
	60x120 24"x48"	60x120 24"x48"	60x60 24"x24"	30x60 12"x24"	EN 16165C	EN 16165A	DCOF	Esagonetta 30x60 12"x24"	Velvet 30x60 12"x24"	Mosaico 30x30 Su Rete 12"x12" (2"x2" Dot)	Battiscopa 8x60 3 1/2"x24"	
Bianco	Nat/Ret	03053B		62150A	62750A	R10	A	> 0,42	63600A		63650	65830
	Lev/Ret		03057C			V3						66090
	Velvet Grip/Ret				63550A	R11	A+B+C	> 0,42	63550A			
Beige	Nat/Ret	03054B		62170A	62780A	R10	A	> 0,42	63620A		64860	66060
	Lev/Ret		03058C			V3						66110
	Velvet Grip/Ret				63570A	R11	A+B+C	> 0,42	63570A			
Tortora	Nat/Ret	03056B		62190A	62840A	R10	A	> 0,42	63640A		65680	66080
	Lev/Ret		03061C			V3						66130
	Velvet Grip/Ret				63590A	R11	A+B+C	> 0,42	63590A			
Terra	Nat/Ret			62180A	62810A	R10	A	> 0,42	63630A		64870	66070
	Lev/Ret					V3						66120
	Velvet Grip/Ret				63580A	R11	A+B+C	> 0,42	63580A			
Grigio	Nat/Ret	03055A		62160A	62770A	R10	A	> 0,42	63610A		63660	65840
	Lev/Ret		03059C			V3						66100
	Velvet Grip/Ret				63560A	R11	A+B+C	> 0,42	63560A			

Purestone

Una vera e propria materia d'arredo, ricavata elaborando l'estetica di diverse pietre esistenti in natura. "Purestone" Piemme è un moderno grès porcellanato dai toni delicati e dalle venature discrete, mai eccessive.

A real furnishing material, obtained by processing the aesthetics of various kinds of natural stones, Piemme "Purestone" is a modern porcelain stoneware with delicate colour shades and discreet and never excessive veins.

Ein echtes Einrichtungsmaterial, gewonnen aus einem Mix der Optik verschiedener Natursteine. Piemme "Purestone" ist ein modernes Feinsteinzeug in zarten Tönen und mit dezenten, unaufdringlichen Aderungen.

Cette véritable révolution en matière d'architecture intérieure est le fruit d'une étude précise sur les différentes pierres existant dans la nature. "Purestone" by Piemme est un grès cérame moderne, aux teintes délicates, aux veines discrètes parfaitement dosées.

5

Colori
Colours
Farben
Couleurs



3

Formati
Sizes
Formate
Formats

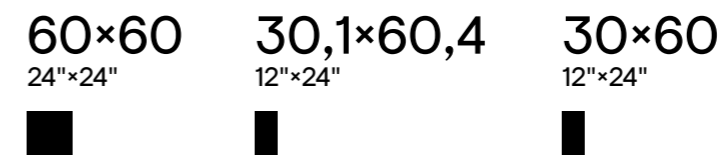

2

Superfici
Surfaces
Oberflächen
Surfaces

Naturale Velvet

2

Strutture 3D
3D structures
Strukturen
Decorations and relief

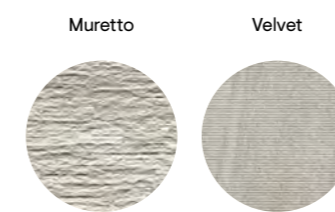

i

Effetto Pietra
Stone Look
Natursteinoptik
Effet Pierre

Rivestimento
Wall Tiles
Wandfliesen
Revêtement

Pavimento
Floor Tiles
Bodenfliesen
Sol

Gres fine porcellanato ad impasto colorato
Coloured-body fine porcelain stoneware
Feinsteinzeug aus farbiger Masse
Grès cérame fin à pâte colorée

Tecnologia digitale
Digital technology
Digital Technologie
Technologie numérique



Purestone

Bianco

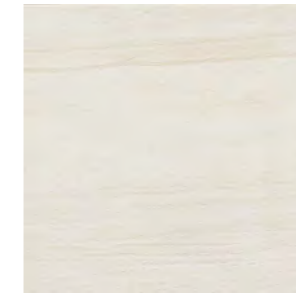

60x60
10840A | Purestone Bianco Nat/Ret



30x60
11160A | Purestone Muretto Bianco Nat/Ret



30,1x60,4
03774A | Purestone Bianco Nat
30x60
10990A | Purestone Bianco Nat/Ret



30x30
39590 | Purestone Mosaico Bianco Nat/Ret



30x60
00530A | Purestone Bianco Velvet Ret

Beige

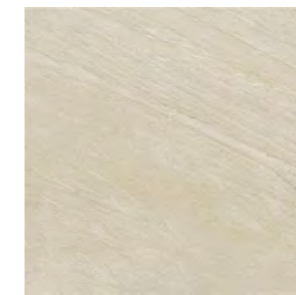

60x60
10850A | Purestone Beige Nat/Ret



30x60
11300A | Purestone Muretto Beige Nat/Ret



30,1x60,4
03775A | Purestone Beige Nat
30x60
11000A | Purestone Beige Nat/Ret



30x30
39600 | Purestone Mosaico Beige Nat/Ret



30x60
00531A | Purestone Beige Velvet Ret

Piombo



60x60
00519A | Purestone Piombo Nat/Ret



30x60
00725A | Purestone Muretto Piombo/Antracite Nat/Ret



30,1x60,4
03777A | Purestone Piombo Nat
30x60
00526A | Purestone Piombo Nat/Ret

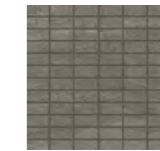

30x30
00540 | Purestone Mosaico Piombo Nat/Ret



30x60
00533A | Purestone Piombo Velvet Ret

Grigio



60x60
10860A | Purestone Grigio Nat/Ret



30x60
11310A | Purestone Muretto Grigio Nat/Ret

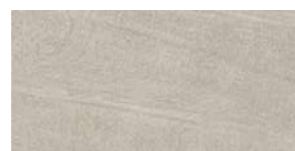

30,1x60,4
03776A | Purestone Grigio Nat

30x60
11070A | Purestone Grigio Nat/Ret



30x30
39610 | Purestone Mosaico Grigio Nat/Ret



30x60
00532A | Purestone Grigio Velvet Ret

Antracite



60x60
00521A | Purestone Antracite Nat/Ret



30x60
00725A | Purestone Muretto Piombo/Antracite Nat/Ret

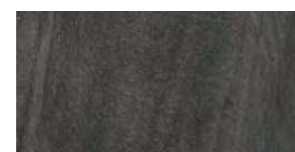

30,1x60,4
03778A | Purestone Antracite Nat

30x60
00527A | Purestone Antracite Nat/Ret

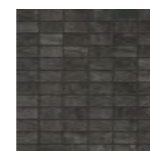

30x30
00541 | Purestone Mosaico Antracite Nat/Ret



30x60
00534A | Purestone Antracite Velvet Ret

Imballi

Packing
Verpackung
Emballage

Formato / Size		± MM	Packing / Verpackung / Emballage							Formato Paletta Size Pallet Format Palette Dim. Palette
			Pezzi/Scatola Pieces/Box Stck/Karton Carreaux/Boite	Mq/Scatola Sqmt/Box Qm/Karton M2/Boite	Kg/Scatola Kgs/Box Kg/Karton Kg/Boite	Scatole/Paletta Boxes/Pallet Karton/Pallet Boite/Palette	Mq/Paletta Sqmt/Pallet Qm/Pallet M2 /Palette	Kg/Paletta Kgs/Pallet Kg/Pallet Kg/Palette		
60x60 Nat/Ret	P	9,5	4	1,44	29,00	32	46,08	928	120x80x75	
30,1x60,4 Nat	P	9,5	7	1,273	25,70	40	50,92	1028	120x80x75	
30x60 Nat/Ret	P	9,5	7	1,26	25,30	40	50,40	1012	120x80x75	
30x60 Velvet Ret	P	9,5	7	1,26	25,30	40	50,40	1012	120x80x75	
30x60 Muretto Ret	P	9,5	7	1,26	25,30	32	40,32	809,6	120x80x75	
30x30 Mosaico (Su Rete)	P	9,5	5	0,45	8,5	60				
Pezzi Speciali / Special Pieces										
8x60 Battiscopa Nat - Nat/Ret	P	9,5	10	0,48	11	72				
30x60 Step	P	9,5	6	1,08	22	36				

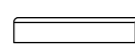
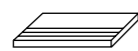

Riepilogo Gamma

Collection
Serie
Gamme

Formati Sizes	Formati / Sizes			EN 16165C	EN 16165A	DCOF	Strutture 3D 3D Structures		Mosaico 30x30 (Su Rete) 12"x12" 1"x2" Dot	Pezzi Speciali Special Pieces	
	60x60 24"x24"	30,1x60,4 12"x24"	30x60 12"x24"				Muretto 30x60 12"x24"	Velvet 30x60 12"x24"		Battiscopa 8x60 3 1/4"x24"	Step 30x60 12"x24"
Bianco	Nat				R10	A	> 0,42				
	Nat/Ret	10840A		10990A	V3 R10	A	> 0,42	11160A		39590	71980
	Velvet/Ret			00530A	R11	A+B+C	> 0,42		00530A		
Beige	Nat		03775A		R10	A	> 0,42				11330
	Nat/Ret	10850A		11000A	V3 R10	A	> 0,42	11300A		39600	71990
	Velvet/Ret			00531A	R11	A+B+C	> 0,42		00531A		
Grigio	Nat		03776A		R10	A	> 0,42				11380
	Nat/Ret	10860A		11070A	V3 R10	A	> 0,42	11310A		39610	72000
	Velvet/Ret			00532A	R11	A+B+C	> 0,42		00532A		
Piombo	Nat		03777A		R10	A	> 0,42				00542
	Nat/Ret	00519A		00526A	V3 R10	A	> 0,42	00725A		00540	00544
	Velvet/Ret			00533A	R11	A+B+C	> 0,42		00533A		
Antracite	Nat		03778A		R10	A	> 0,42				00543
	Nat/Ret	00521A		00527A	V3 R10	A	> 0,42	00725A		00541	00545
	Velvet/Ret			00534A	R11	A+B+C	> 0,42		00534A		

Castlestone

Con Castlestone il fascino della pietra è ora al servizio dell'arredamento architettonico.

Thanks to Castlestone, the appeal of stone is now at the service of architectural design.

Mit Castlestone steht der Zauber des Natursteins heute im Dienst der architektonischen Raumgestaltung.

Avec Castlestone, le charme de la pierre est maintenant au service de l'architecture d'intérieur.

5

Colori
Colours
Farben
Couleurs

White



Almond



Grey



Musk



Black

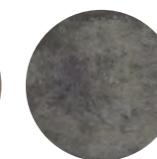

2

Formati
Sizes
Formate
Formats

60×60
24"×24"



30×60
12"×24"



2

Superfici
Surfaces
Oberflächen
Surfaces

Naturale

Antislip

1

Strutture 3D
3D structures
Strukturen
Decorations and relief

Muretto



i

Effetto Pietra
Stone Look
Natursteinoptik
Effet Pierre

Rivestimento
Wall Tiles
Wandfliesen
Revêtement

Pavimento
Floor Tiles
Bodenfliesen
Sol

Gres fine porcellanato ad impasto colorato
Coloured-body fine porcelain stoneware
Feinsteinzeug aus farbiger Masse
Grès cérame fin à pâte colorée

Tecnologia digitale
Digital technology
Digital Technologie
Technologie numérique

White



60x60
00126A | Castlestone White Nat/Ret



60x60
00456A | Castlestone Antislip White Ret



30x60
00136A | Castlestone White Nat/Ret



30x60
00224A | Castlestone Mix Cold Ret

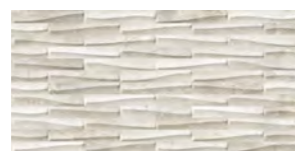

30x60
00149A | Castlestone Muretto White Ret

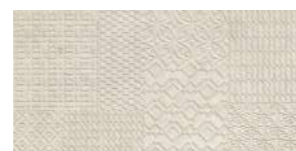

30x60
***00282** | Castlestone Inciso White Ret

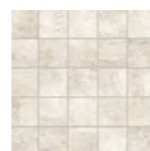

30x30
00159 | Castlestone Mosaico White Ret

Almond



60x60
00127A | Castlestone Almond Nat/Ret



60x60
00457A | Castlestone Antislip Almond Ret



30x60
00137A | Castlestone Almond Nat/Ret



30x60
00225A | Castlestone Mix Warm Ret

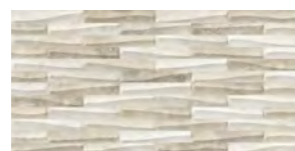

30x60
00150A | Castlestone Muretto Almond Ret

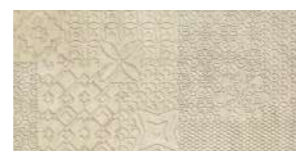

30x60
***00283** | Castlestone Inciso Almond Ret

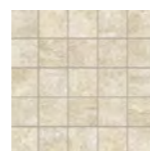

30x30
00160 | Castlestone Mosaico Almond Ret

* Decori realizzati con smalti e metalli preziosi. Vedere nota a pag. 382-383
Decors made with glazes and precious metals. See note on pages 382-383
Dekore aus Glasuren und Edelmetallen. Siehe Hinweis auf Seiten 382-383
Décors réalisés avec des émaux et des métaux précieux. Voir note aux pages 382-383

Grey



60x60
00128A | Castlestone Grey Nat/Ret

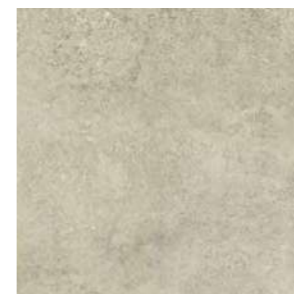

60x60
00458A | Castlestone Antislip Grey Ret

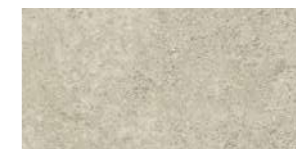

30x60
00138A | Castlestone Grey Nat/Ret



30x60
00224A | Castlestone Mix Cold Ret

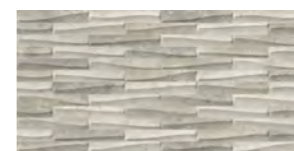

30x60
00151A | Castlestone Muretto Grey Ret



30x60
***00284** | Castlestone Inciso Grey Ret

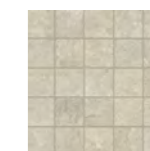

30x30
00161 | Castlestone Mosaico Grey Ret

Musk



60x60
00129A | Castlestone Musk Nat/Ret

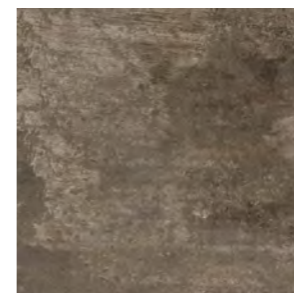

60x60
00459A | Castlestone Antislip Musk Ret



30x60
00139A | Castlestone Musk Nat/Ret



30x60
00225A | Castlestone Mix Warm Ret

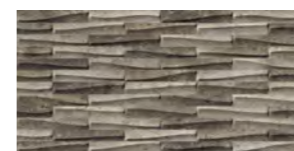

30x60
00152A | Castlestone Muretto Musk Ret



30x30
00162 | Castlestone Mosaico Musk Ret

* Decori realizzati con smalti e metalli preziosi. Vedere nota a pag. 382-383
Decors made with glazes and precious metals. See note on pages 382-383
Dekore aus Glasuren und Edelmetallen. Siehe Hinweis auf Seiten 382-383
Décors réalisés avec des émaux et des métaux précieux. Voir note aux pages 382-383

Black



60x60
00130A | Castlestone Black Nat/Ret



60x60
00460A | Castlestone Antislip Black Ret



30x60
00141A | Castlestone Black Nat/Ret



30x60
00224A | Castlestone Mix Cold Ret

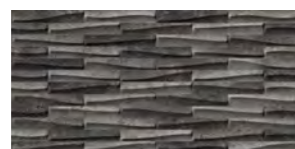

30x60
00153A | Castlestone Muretto Black Ret

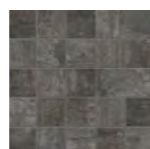

30x30
00163 | Castlestone Mosaico Black Ret

* Decori realizzati con smalti e metalli preziosi. Vedere nota a pag. 382-383
Decors made with glazes and precious metals. See note on pages 382-383
Dekore aus Glasuren und Edelmetallen. Siehe Hinweis auf Seiten 382-383
Décors réalisés avec des émaux et des métaux précieux. Voir note aux pages 382-383

Imballi

Packing
Verpackung
Emballage

Formato / Size		± MM	Pezzi/Scatola Pieces/Box Stck/Karton Carreaux/Boîte	Mq/Scatola Sqmt/Box Qm/Karton M2/Boîte	Kg/Scatola Kgs/Box Kg/Karton Kg/Boîte	Scatole/Paletta Boxes/Pallet Karton/Pallet Boîte/Palette	Mq/Paletta Sqmt/Pallet Qm/Pallet M2 /Palette	Kg/Paletta Kgs/Pallet Kg/Pallet Kg/Palette	Formato Paletta Size Pallet Format Pallet Dim. Palette
60x60 Nat/Ret	P	9,5	4	1,44	29	32	46,08	928	120x80x75
60x60 Antislip/Ret	P	9,5	4	1,44	29	32	46,08	928	120x80x75
30x60 Nat/Ret	P	9,5	7	1,26	25,30	40	50,40	1012	120x80x75
30x60 Muretto	P	9,5	7	1,26	25,30	32	40,32	809,60	120x80x75
30x60 Mix	P	9,5	7	1,26	25,30	40	50,40	1012	120x80x75
30x60 Inciso	P	9,5	6	1,08	21,5	21	22,68	451,5	120x80x75
30x30 Mosaico (Su Rete)	P	9,5	5	0,45	8,5	60			
Pezzi Speciali / Special Pieces									
8x60 Battiscopa	P	9,5	10	0,48	11	72			
30x60 Step	P	9,5	6	1,08	21,5	36			

Riepilogo Gamma

Collection
Serie
Gamme

Formati Sizes	60x60 24"x24"		30x60 12"x24"		EN 16165C EN 16165A DCOF			Strutture 3D 3D Structures	Mix Warm 30x60 12"x24"	Mix Cold 30x60 12"x24"	Inciso 30x60 12"x24"	Mosaico 30x30 (Su Rete) 12"x12" 2"x2" Dot	Pezzi Speciali Special Pieces	
	± 9,5	± 9,5					± 9,5	± 9,5	± 9,5	± 9,5	± 9,5	± 9,5	± 9,5	± 9,5
	Nat/Ret	00126A	00136A	V3	R10	A+B	> 0,42	00149A	00225A	00224A	00282	00159	00179	00189
	Antislip/Ret	00456A			R11	A+B+C								
	Nat/Ret	00127A	00137A	V3	R10	A+B	> 0,42	00150A	00225A		00283	00160	00180	00190
	Antislip/Ret	00457A			R11	A+B+C								
	Nat/Ret	00128A	00138A	V3	R10	A+B	> 0,42	00151A		00224A	00284	00161	00181	00191
	Antislip/Ret	00458A			R11	A+B+C								
	Nat/Ret	00129A	00139A	V3	R10	A+B	> 0,42	00152A	00225A			00162	00182	00192
	Antislip/Ret	00459A			R11	A+B+C								
	Nat/Ret	00130A	00141A	V3	R10	A+B	> 0,42	00153A		00224A		00163	00183	00193
	Antislip/Ret	00460A			R11	A+B+C								

More

More è una moderna superficie di design; un equilibrato blend di pietre messo a punto dalla ricerca Piemme e declinato in numerosi formati e finiture; il tutto arricchito da superfici tridimensionali e decorazioni coordinate che rendono More un vero e proprio materiale d'architettura.

More is a modern design surface; it is a balanced blend of stones developed by Piemme research and available in numerous shapes and finishes; all this is enhanced by three-dimensional surfaces and decorations which make More a real architectural material.

More ist eine moderne Design-Oberfläche; ein ausgewogener Mix aus Steinen aus den Piemme-Forschungslabors. In zahlreichen Formaten und Oberflächenversionen erhältlich. Bereichert durch 3D-Oberflächen und passend abgestimmte Dekore, die More zu einem wahren Architektur-Material machen.

More est une surface au design moderne, un mélange subtilement dosé de pierres mis au point par la Recherche Piemme, décliné en de nombreux formats et finitions. Le tout est enrichi de surfaces tridimensionnelles et de décors coordonnés faisant de More un matériau d'architecture proprement dit.

5

Colori
Colours
Farben
Couleurs

Bianco



Avorio



Tortora

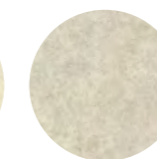

Perla



Grigio

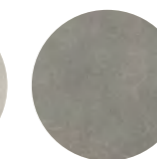

1

Formati
Sizes
Formate
Formats

30×60
12"×24"



1

Superfici
Surfaces
Oberflächen
Surfaces

Naturale

2

Strutture 3D
3D structures
Strukturen
Decorations and relief

Design



Muretto



i

Effetto Pietra
Stone Look
Natursteinoptik
Effet Pierre

Rivestimento
Wall Tiles
Wandfliesen
Revêtement

Pavimento
Floor Tiles
Bodenfliesen
Sol

Gres fine porcellanato ad impasto colorato
Coloured-body fine porcelain stoneware
Feinsteinzeug aus farbiger Masse
Grès cérame fin à pâte colorée

Tecnologia digitale
Digital technology
Digital Technologie
Technologie numérique



More

Bianco



10x30

00665 | More Bianco Nat/Ret

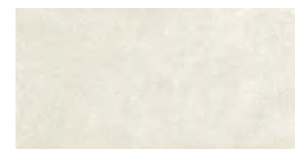

30x60

00612A | More Bianco Nat/Ret

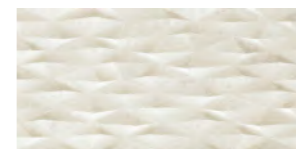

30x60

00648A | More Design Bianco Ret

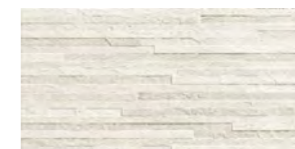

30x60

00719A | More Muretto Bianco Ret

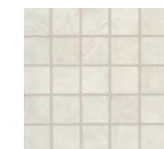

30x30

00659 | More Mosaico Bianco Nat/Ret

Avorio



10x30

00667 | More Avorio Nat/Ret

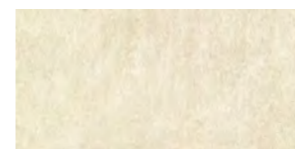

30x60

00614A | More Avorio Nat/Ret



30x60

00651A | More Design Avorio Ret



30x60

00722A | More Muretto Avorio Ret

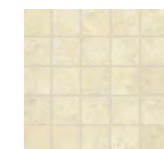

30x30

00662 | More Mosaico Avorio Nat/Ret

Tortora



10x30

00668 | More Tortora Nat/Ret

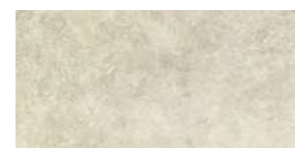

30x60

00615A | More Tortora Nat/Ret



30x60

00652A | More Design Tortora Ret



30x60

00723A | More Muretto Tortora Ret

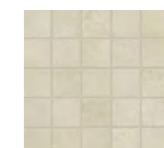

30x30

00663 | More Mosaico Tortora Nat/Ret

Perla

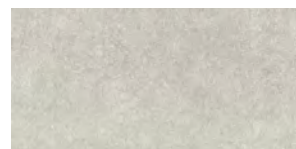

30x60
00613A | More Perla Nat/Ret

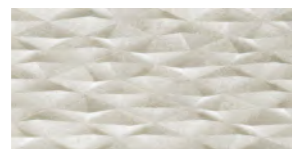

30x60
00649A | More Design Perla Ret

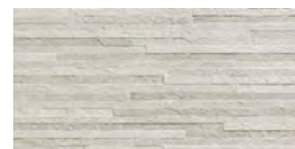

30x60
00721A | More Muretto Perla Ret

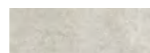

10x30
00666 | More Perla Nat/Ret

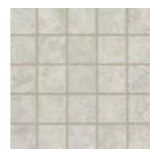

30x30
00661 | More Mosaico Perla Nat/Ret

Grigio



30x60
00616A | More Grigio Nat/Ret



30x60
00653A | More Design Grigio Ret

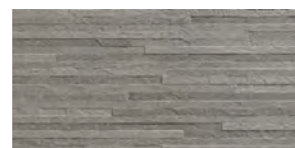

30x60
00724A | More Muretto Grigio Ret

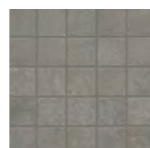

30x30
00664 | More Mosaico Grigio Nat/Ret



10x30
00669 | More Grigio Nat/Ret

Imballi

Packing
Verpackung
Emballage

Formato / Size		± MM	Pezzi/Scatola Pieces/Box Stck/Karton Carreaux/Boîte	Mq/Scatola Sqmt/Box Qm/Karton M2/Boîte	Kg/Scatola Kgs/Box Kg/Karton Kg/Boîte	Scatole/Paletta Boxes/Pallet Karton/Pallet Boîte/Palette	Mq/Paletta Sqmt/Pallet Qm/Pallet M2 /Palette	Kg/Paletta Kgs/Pallet Kg/Pallet Kg/Palette	Formato Paletta Size Pallet Format Pallet Dim. Palette
30x60 Nat/Ret	P	9,5	7	1,26	25,30	40	50,4	1012	120x80x75
30x60 Design	P	9,5	7	1,26	25,30	32	40,32	809,6	120x80x75
30x60 Muretto	P	9,5	7	1,26	25,30	32	40,32	809,6	120x80x75
30x30 Mosaico (Su Rete)	P	9,5	5	0,45	8,5	60			
10x30	P	9,5	12	0,36	7,4	84			
Pezzi Speciali / Special Pieces									
8x60 Battiscopa	P	9,5	10	0,48	11	72			
30x60 Step	P	9,5	6	1,08	21,5	36			

Riepilogo Gamma

Collection
Serie
Gamme

	Formati Sizes	±	EN 16165C	EN 16165A	DCOF	Strutture 3D 3D Structures		Mosaico 30x30 (Su Rete) 12"x12" (2"x2" Dot)	10x30 4"x12"	Pezzi Speciali Special Pieces	
						Design 30x60 12"x24"	Muretto 30x60 12"x24"				
Bianco	Nat/Ret	00612A	V3	R10	A	> 0,42	00648A	00719A	00659	00665	00693
Avorio	Nat/Ret	00614A	V3	R10	A	> 0,42	00651A	00722A	00662	00667	00695
Tortora	Nat/Ret	00615A	V3	R10	A	> 0,42	00652A	00723A	00663	00668	00696
Perla	Nat/Ret	00613A	V3	R10	A	> 0,42	00649A	00721A	00661	00666	00694
Grigio	Nat/Ret	00616A	V3	R10	A	> 0,42	00653A	00724A	00664	00669	00697

Moon

La serie Moon nasce con l'obiettivo di coniugare estetica e funzionalità, dando vita a una pietra ispirata al travertino dalle caratteristiche tecniche avanzate ma con un design semplice e trasversale, adatto sia a contesti residenziali che commerciali. La superficie si distingue per l'elevata resistenza al carico e alla scivolosità, rispondendo a esigenze prestazionali particolarmente elevate.

The Moon series was created to combine aesthetics and functionality, resulting in a travertine-inspired stone with advanced technical features and a simple, versatile design – ideal for both residential and commercial spaces. Its surface is distinguished by high resistance to load and slipperiness, meeting demanding performance standards.

Die Serie Moon wurde mit dem Ziel entwickelt, Ästhetik und Funktionalität zu vereinen. Es ist ein Stein entstanden, inspiriert vom Travertin, mit fortschrittlichen technischen Eigenschaften und einem schlichten, vielseitigen Design, das sich sowohl für Wohn- als auch für Gewerbebereiche eignet. Die Oberfläche zeichnet sich durch ihre hohe Belastbarkeit und Rutschfestigkeit aus und erfüllt höchste Leistungsanforderungen.

La série Moon est née avec l'objectif de conjuguer esthétique et fonctionnalité, en donnant vie à une pierre inspirée du travertin, dotée de caractéristiques techniques avancées mais d'un design simple et transversal, adapté aussi bien aux contextes résidentiels que commerciaux. La surface se distingue par sa grande résistance à la charge et à la glissance, répondant à des exigences de performance particulièrement élevées.

3

Colori
Colours
Farben
Couleurs

White



Beige



Greige

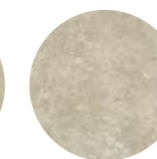

4

Formati
Sizes
Formate
Formats

60×120
24"×48"



80×80
31½"×31½"



60×60
24"×24"



30×60
12"×24"



2

Superfici
Surfaces
Oberflächen
Surfaces

Naturale

Grip

2

Strutture 3D
3D structures
Strukturen
Decorations and relief

Raffia



Linear

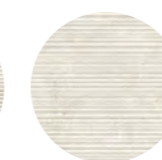

i

Effetto Pietra
Stone Look
Natursteinoptik
Effet Pierre



Rivestimento
Wall Tiles
Wandfliesen
Revêtement

Pavimento
Floor Tiles
Bodenfliesen
Sol

Gres fine porcellanato ad impasto colorato
Coloured-body fine porcelain stoneware
Feinsteinzeug aus farbiger Masse
Grès cérame fin à pâte colorée

Tecnologia digitale
Digital technology
Digital Technologie
Technologie numérique

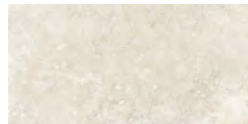
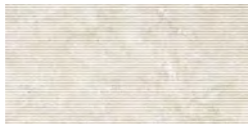
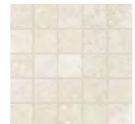
White

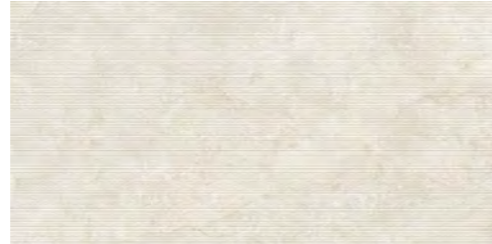
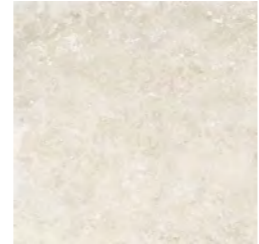
			
80x80 06257 Moon White Nat/Ret 06279 Moon White Grip/Ret	30x60 06248 Moon White Nat/Ret	30x60 06407 Raffia White Nat/Ret	30x30 06290 Mosaico Moon White Nat/Ret
			
60x120 06254 Moon White Nat/Ret	60x120 06273 Linear White Nat/Ret	60x60 06251 Moon White Nat/Ret 06276 Moon White Grip/Ret	

Beige



			
80x80 06258 Moon Beige Nat/Ret 06280 Moon Beige Grip/Ret	30x60 06249 Moon Beige Nat/Ret	30x60 06408 Raffia Beige Nat/Ret	30x30 06291 Mosaico Moon Beige Nat/Ret
			
60x120 06255 Moon Beige Nat/Ret	60x120 06274 Linear Beige Nat/Ret	60x60 06252 Moon Beige Nat/Ret 06277 Moon Beige Grip/Ret	

Greige

			
80x80 06270 Moon Greige Nat/Ret 06281 Moon Greige Grip/Ret	30x60 06250 Moon Greige Nat/Ret	30x60 06409 Raffia Greige Nat/Ret	30x30 06292 Mosaico Moon Greige Nat/Ret
			
60x120 06256 Moon Greige Nat/Ret	60x120 06275 Linear Greige Nat/Ret	60x60 06253 Moon Greige Nat/Ret 06278 Moon Greige Grip/Ret	







Imballi

Packing
Verpackung
Emballage

Formati Sizes		± MM	 Pezzi Scatola Pieces/Box Stck/Karton Carreaux/Boite	 Mq/Scatola Sqmt/Box Qm/Karton M2/Boite	 Kg/Scatola Kgs/Box Kg/Karton Kg/Boite	 Scatole/Paletta Boxes/Pallet Karton/Palette Boite/Palette	 Mq/Paletta Sqmt/Pallet Qm/Pallet M2/Palette	 Kg/Paletta Kgs/Pallet Kg/Pallet Kg/Palette	 Formato Paletta Size Pallet Format Pallet Dim. Palette
60x120 (24"x48") Nat/Ret	P	8,5	2	1,44	28,00	44	63,36	1232	120x80x75
80x80 (31½"x31½") Nat/Ret	P	8,5	2	1,28	24,50	54	69,12	1323	124x80x96
60x60 (24"x24") Nat/Ret - Grip/Ret	P	9,5	4	1,44	29,00	32	46,08	928	120x80x75
30x60 (12"x24") Nat/Ret	P	9,5	7	1,26	25,30	40	50,40	1012	120x80x75
60x120 (24"x48") Linear Nat/Ret	P	8,5	2	1,44	28,00	44	63,36	1232	120x80x75
30x60 (12"x24") Raffia Nat/Ret	P	9,5	7	1,26	25,30	32	40,32	809,60	120x80x75
30x30 (12"x12") Mosaico Nat/Ret	P	9,5	5	0,45	8,50	60	-	-	-
Pezzi Speciali / Special Pieces									
4,5x60 (1¾"x24") Battiscopa Nat/Ret	P	9,5	14	0,378 - m.l. 8,40	8,00	80	-	-	-
30x60 (12"x24") Step Nat/Ret	P	8,5	6	1,08	22,00	36	-	-	-

Riepilogo Gamma

Collection
Serie
Gamme

	Formati Sizes												
		60x120 24"x48"	80x80 31½"x31½"	60x60 24"x24"	30x60 12"x24"	DIN 51130	DIN 51097	Linear 60x120 - 24"x48"	Raffia 30x60 - 12"x24"	Mosaico 30x30 - 12"x12"	Battiscopa 4,5x60 - 1¾"x24"	Step 30x60 - 12"x24"	
		± 8,5	± 8,5	± 9,5	± 9,5		± 8,5	± 9,5	± 9,5	± 9,5	± 9,5		
	Nat/Ret	06254	06257	06251	06248	V2	R10	A+B	06273	06407	06290	06293	06296
	Grip/Ret		06279	06276			R11	A+B+C					
	Nat/Ret	06255	06258	06252	06249	V2	R10	A+B	06274	06408	06291	06294	06297
	Grip/Ret		06280	06277			R11	A+B+C					
	Nat/Ret	06256	06270	06253	06250	V2	R10	A+B	06275	06409	06292	06295	06298
	Grip/Ret		06281	06278			R11	A+B+C					

Artdesia 2.0

Artdesia 2.0: una collezione, ispirata alle rocce sedimentarie, in grado di rispondere al meglio alle esigenze di architetti e progettisti alla ricerca di una estetica minimale caratterizzata da una eleganza senza tempo.

Artdesia 2.0: a collection, inspired by sedimentary rocks, that best meets the needs of architects and designers looking for a minimalist design characterized by a timeless elegance.

Artdesia 2.0: eine vom Schiefer-Stein inspirierte Kollektion, die den Bedürfnissen von Architekten und Designern, die eine minimalistische Ästhetik mit zeitloser Eleganz suchen, am besten gerecht wird.

Artdesia 2.0: une collection inspirée des roches sédimentaires, capable de répondre au mieux aux besoins des architectes et designers à la recherche d'une esthétique minimale caractérisée par une élégance intemporelle.

5

Colori
Colours
Farben
Couleurs

Ivory



Sand



Silver



Grey



Black

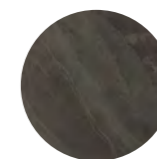

3

Formati
Sizes
Formate
Formats

60×120
24"×48"



60×60
24"×24"



30×60
12"×24"



3

Superfici
Surfaces
Oberflächen
Surfaces

Naturale

Antislip

Grip

i

Effetto Pietra
Stone Look
Natursteinoptik
Effet Pierre

Rivestimento
Wall Tiles
Wandfliesen
Revêtement

Pavimento
Floor Tiles
Bodenfliesen
Sol

Gres fine porcellanato ad impasto colorato
Coloured-body fine porcelain stoneware
Feinsteinzeug aus farbiger Masse
Grès cérame fin à pâte colorée

Tecnologia digitale
Digital technology
Digital Technologie
Technologie numérique

Ivory



60x120
04987A | Artdesia 2.0 Ivory Nat/Ret

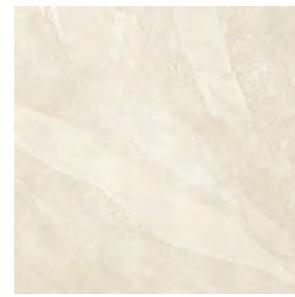

60x60
04991 | Artdesia 2.0 Ivory Nat/Ret
05368A | Artdesia 2.0 Ivory Grip/Ret \pm 20mm



30x60
04994 | Artdesia 2.0 Ivory Nat/Ret

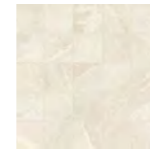

30x30
04998 | Mosaico Art Ivory Nat/Ret

Sand

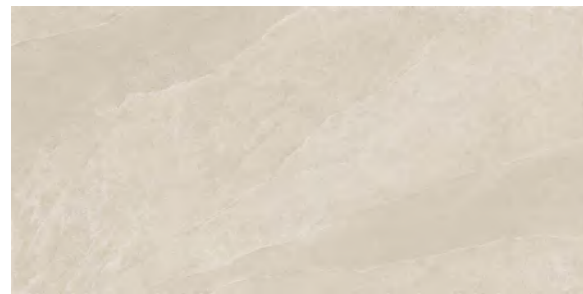

60x120
05651 | Artdesia 2.0 Sand Nat/Ret
05659 | Artdesia 2.0 Sand Antislip/Ret

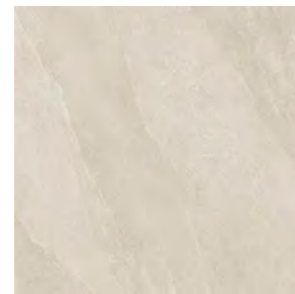

60x60
05649 | Artdesia 2.0 Sand Nat/Ret



30x60
05647 | Artdesia 2.0 Sand Nat/Ret



30x30
05653 | Mosaico Art Sand Nat/Ret

Silver



60x120
05652 | Artdesia 2.0 Silver Nat/Ret
05660 | Artdesia 2.0 Silver Antislip/Ret

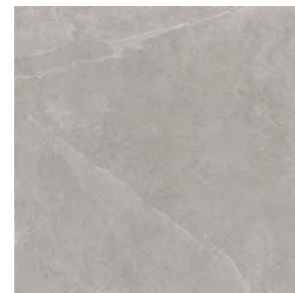

60x60
05650 | Artdesia 2.0 Silver Nat/Ret



30x60
05648 | Artdesia 2.0 Silver Nat/Ret



30x30
05654 | Mosaico Art Silver Nat/Ret

Grey

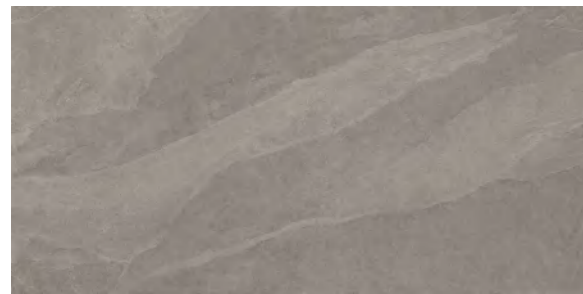

60x120
04988A | Artdesia 2.0 Grey Nat/Ret

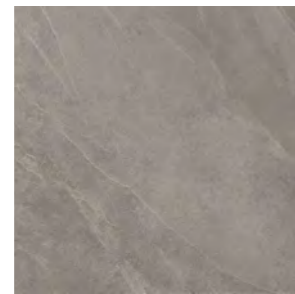

60x60
04992 | Artdesia 2.0 Grey Nat/Ret
05369A | Artdesia 2.0 Grey Grip/Ret \pm 20mm



30x60
04995 | Artdesia 2.0 Grey Nat/Ret

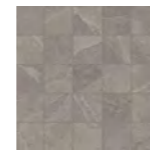

30x30
04999 | Mosaico Art Grey Nat/Ret

Black



60x120
04989A | Artdesia 2.0 Black Nat/Ret

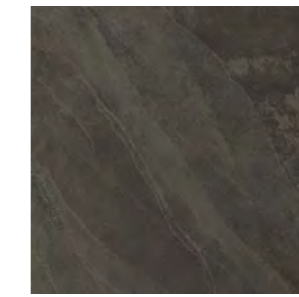

60x60
04993 | Artdesia 2.0 Black Nat/Ret

PDF Merchandising



30x60
04996 | Artdesia 2.0 Black Nat/Ret

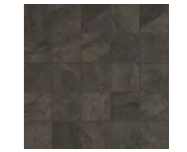

30x30
05000 | Mosaico Art Black Nat/Ret

Imballi

Packing Verpackung Emballage	Formati Sizes	\pm MM	Pezzi Scatola Pieces/Box Stck/Karton Carreaux/Boite	Mq/Scatola Sqmt/Box Qm/Karton M2/Boite	Kg/Scatola Kgs/Box Kg/Karton Kg/Boite	Scatole/Paletta Boxes/Pallet Karton/Palette Boite/Palette	Mq/Paletta Sqmt/Pallet Qm/Pallet M2/Palette	Kg/Paletta Kgs/Pallet Kg/Pallet Kg/Palette	Formato Paletta Size Pallet Format Pallet Dim. Palette	
	60x120 (24"x48") Nat/Ret	P	8,5	2	1,44	28,00	44	63,36	1232	122x100x76
	60x60 (24"x24") Nat/Ret	P	8,5	4	1,44	26,00	40	57,6	1040	122x82x75
	60x60 (24"x24") Grip/Ret (A)	P	20	2	0,72	31,40	32	23,04	1004,80	120x80x75
	30x60 (12"x24") Nat/Ret	P	8,5	7	1,26	22,50	48	60,48	1080	120x80x75
	30x30 (12"x12") Mosaico Nat/Ret	P	8,5	5	0,45	8,50	60	-	-	-
	4,5x60 (1 1/2"x24") Battiscopa Nat/Ret	P	8,5	14	0,378	8,00	80	-	-	-
	30x60 (12"x24") Step Nat/Ret	P	8,5	6	1,08	21,5	36	-	-	-

Riepilogo Gamma

Collection Serie Gamme	Formati Sizes	60x120 24"x48"	60x60 24"x24"	60x60 24"x24"	30x60 12"x24"	EN 16165C	EN 16165A	DCOF	Mosaico 30x30 - 12"x12"	Battiscopa 4,5x60 - 1 1/2"x24"	Step 30x60 - 12"x24"	
		\pm 8,5	\pm 8,5	\pm 20	\pm 8,5				\pm 8,5	\pm 8,5	\pm 8,5	
Ivory	Nat/Ret	04987A	04991		04994	V2	R10	A+B	>0.42	04998	05001	05004
	Grip/Ret			05368A			R11	A+B+C	>0.42			
Sand	Nat/Ret	05651	05649		05647	V2	R10	A+B	>0.42	05653	05655	05657
	Antislip/Ret	05659					R11	A+B+C	>0.42			
Silver	Nat/Ret	05652	05650		05648	V2	R10	A+B	>0.42	05654	05656	05658
	Antislip/Ret	05660					R11	A+B+C	>0.42			
Grey	Nat/Ret	04988A	04992		04995	V2	R10	A+B	>0.42	04999	05002	05005
	Grip/Ret			05369A			R11	A+B+C	>0.42			
Black	Nat/Ret	04989A	04993		04996	V2	R10	A+B	>0.42	05000	05003	05006

CONTEMPORARY

Contemporaneo / Moderne / Contemporain



- 144 Makro Deco PREMIUM /
- 154 Makro Project PREMIUM /
- 164 Homey PREMIUM /
- 198 Materia ESSENZA /
- 216 Fragments ESSENZA /
- 220 Venetian Marble EMPORIO /



INSPIRATION FOR UNIQUE SPACE

Makro Deco

Makro Deco è il contenitore dedicato a tutte le decorazioni applicate su lastra. Comprende una serie di soluzioni decorative ideate per esaltare il grande formato, con pattern progettati per offrire continuità visiva, armonia compositiva e un forte impatto estetico. Si tratta di proposte che arricchiscono la superficie, valorizzandone le dimensioni e conferendo un carattere distintivo a ogni progetto.

Makro Deco is the collection dedicated to all decorative finishes applied to slabs. It includes a series of decorative solutions designed to enhance large formats, with patterns created to provide visual continuity, compositional harmony, and a strong aesthetic impact. These proposals enrich the surface, highlighting its dimensions and giving each project a distinctive character.

Makro Deco ist die Designwelt, die allen auf Großformatplatten realisierten Dekoren gewidmet ist. Sie umfasst eine Auswahl dekorativer Lösungen, die entwickelt wurden, um das große Format hervorzuheben mit Mustern, die visuelle Kontinuität, kompositorische Harmonie und eine starke ästhetische Wirkung gewährleisten. Oberflächen, die an Ausdruckskraft gewinnen, ihre Dimensionen betonen und jedem Projekt eine unverwechselbare Identität verleihen.

Makro Deco est l'univers dédié à l'ensemble des décorations appliquées sur dalle. Il réunit une collection de solutions décoratives conçues pour sublimer le grand format, grâce à des motifs pensés pour offrir continuité visuelle, harmonie de composition et fort impact esthétique. Des propositions qui enrichissent la surface, en valorisent les dimensions et confèrent une identité distinctive à chaque projet.

Blossom è un rivestimento ceramico di grande formato, incluso nella serie **Makro Deco**, sviluppato con la tecnologia avanzata **Synchro Digit Piemme**. Un decoro dal linguaggio naturale e contemporaneo, pensato per arricchire gli spazi con eleganza e personalità.

Blossom is a large-format ceramic covering, part of the **Makro Deco** collection, developed using **Piemme's** advanced **Synchro Digit** technology. It features a natural, contemporary design, created to enrich spaces with elegance and personality.

Blossom ist eine keramische Großformatverkleidung aus der Serie **Makro Deco**, entwickelt mit der fortschrittlichen Technologie **Synchro Digit Piemme**. Ein Dekor mit einer natürlichen und zugleich zeitgemäßen Designsprache, geschaffen, um Räume mit Eleganz und Persönlichkeit zu bereichern.

Blossom est un revêtement céramique grand format, intégré à la série **Makro Deco**, développé grâce à la technologie avancée **Synchro Digit Piemme**. Un décor au langage naturel et contemporain, imaginé pour enrichir les espaces avec élégance et personnalité.

4

Colori
Colours
Farben
Couleurs



2

Formati
Sizes
Formate
Formats

120×280
48"×110"

60×120
24"×48"

1

Superfici
Surfaces
Oberflächen
Surfaces

Naturale

La grafica tra i vari pezzi non è continuativa. The graphics between the various pieces are not continuous. Die Grafik zwischen den verschiedenen Teilen ist nicht durchgehend. Le graphisme entre les différentes pièces n'est pas continu.

i



Tecnologia - Technology - Technologie:
Synchro Digit Piemme®
Superficie con struttura digitale sincronizzata
Synchronized digital structured surface
Im synchronisierten Digitaldruckverfahren hergestellte 3D-Oberfläche
Surface avec texture et finition par impression numérique synchronisée

Gres fine porcellanato ad impasto colorato
Coloured-body fine porcelain stoneware
Feinsteinzeug aus farbiger Masse
Grès cérame fin à pâte colorée

Effetto Contemporaneo
Contemporary effect
Moderne Wirkung
Effet Contemporain

Rivestimento
Wall Tiles
Wandfliesen
Revêtement

Makro Deco

Blossom White

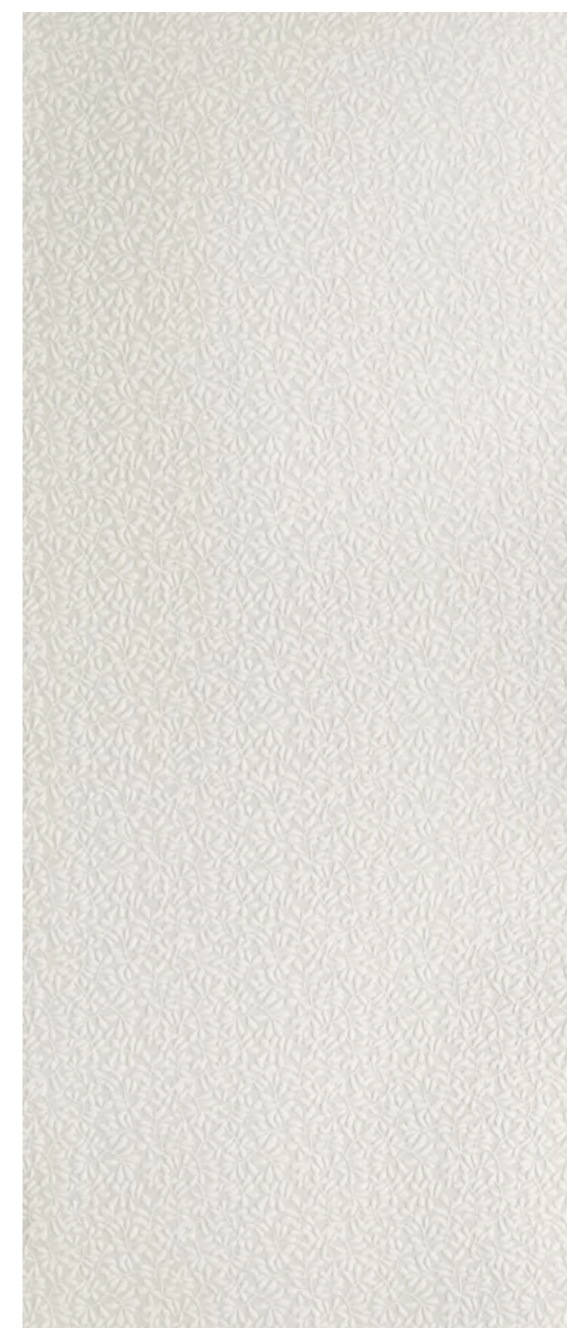

120x280

06336 | Blossom White Nat/Ret



60x120

06388 | Blossom White Nat/Ret

La grafica tra i vari pezzi non è continuativa.
The graphics between the various pieces are not continuous.
Die Grafik zwischen den verschiedenen Teilen ist nicht durchgehend.
Le graphisme entre les différentes pièces n'est pas continu.

Abbinabilità - Matching - Passende Kombination - Coloris Compatibles

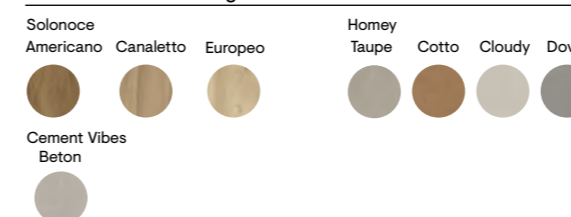

Makro Deco

Blossom Beige



120x280

06337| Blossom Beige Nat/Ret



60x120

06389| Blossom Beige Nat/Ret

La grafica tra i vari pezzi non è continuativa.
The graphics between the various pieces are not continuous.
Die Grafik zwischen den verschiedenen Teilen ist nicht durchgehend.
Le graphisme entre les différentes pièces n'est pas continu.

Abbinabilità - Matching - Passende Kombinatione - Coloris Compatibles

Solonoce

Americano Canaletto Europeo



Homey

Chalk Taupe Cotto Cloudy Dove



Cement Vibes

Malta Fango



Makro Deco

Blossom Green



120x280

06338 | Blossom Green Nat/Ret



60x120

06391 | Blossom Green Nat/Ret

La grafica tra i vari pezzi non è continuativa.
The graphics between the various pieces are not continuous.
Die Grafik zwischen den verschiedenen Teilen ist nicht durchgehend.
Le graphisme entre les différentes pièces n'est pas continu.

Abbinabilità - Matching - Passende Kombinatione - Coloris Compatibles

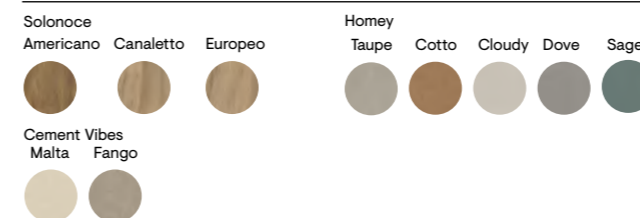



Blossom Blue



120x280
06339 | Blossom Blue Nat/Ret



60x120
06392 | Blossom Blue Nat/Ret

		120x280 48"x110"	60x120 24"x48"
		± 6	± 8,5
	Nat/Ret	06336	06388
	Nat/Ret	06337	06389
	Nat/Ret	06338	06391
	Nat/Ret	06339	06392

La grafica tra i vari pezzi non è continuativa.
The graphics between the various pieces are not continuous.
Die Grafik zwischen den verschiedenen Teilen ist nicht durchgehend.
Le graphisme entre les différentes pièces n'est pas continu.

Abbinabilità - Matching

Passende Kombinatione - Coloris Compatibles

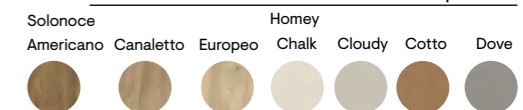

Formati Sizes		± MM	Pezzi Scatola Pieces/Box Stck/Karton Carreaux/Boîte	Mq/Scatola Sqmt/Box Qm/Karton M2/Boîte	Kg/Scatola Kgs/Box Kg/Karton Kg/Boîte	Scatole/Paletta Boxes/Pallet Karton/Palette Boîte/Palette	Mq/Paletta Sqmt/Pallet Qm/Pallet M2/Palette	Kg/Paletta Kgs/Pallet Kg/Pallet Kg/Palette	Formato Paletta Size Pallet Format Pallet Dim. Palette
120x280 (48"x110") Nat/Ret	P	6	1	3,36	46,50	20	67,20	930	143x294x35
60x120 (24"x48") Nat/Ret	P	8,5	2	1,44	28,00	44	63,36	1232	122x100x76

CERAMIC SOLUTION FOR EVERY PROJECT

Makro Project

Makro Project è una serie sviluppata per rispondere alle esigenze specifiche del mondo contract, dell'hospitality e dell'arredamento nautico. L'obiettivo è offrire soluzioni affidabili, versatili e performanti, capaci di adattarsi a contesti ad alto traffico e a progetti che richiedono standard qualitativi elevati. Accanto ai formati disponibili a catalogo, la linea prevede anche la possibilità di realizzare dimensioni personalizzate su richiesta, così da garantire la massima libertà creativa e una perfetta integrazione con ogni concept architettonico.

Makro Project is a series developed to meet the specific needs of the contract, hospitality, and nautical furniture sectors. The aim is to provide reliable, versatile, and high-performance solutions, capable of adapting to high-traffic environments and projects that require high-quality standards. In addition to the available standard sizes, the collection also offers the possibility of creating custom dimensions upon request, ensuring maximum creative freedom and perfect integration with any architectural concept.

Makro Project ist eine Serie, die entwickelt wurde, um den spezifischen Anforderungen der Bereiche Contract, Hospitality und Yacht-Design gerecht zu werden. Ziel ist es, zuverlässige, vielseitige und leistungsstarke Lösungen anzubieten, die sich ideal für stark frequentierte Umgebungen und Projekte mit höchsten Qualitätsstandards eignen. Neben den im Katalog verfügbaren Formaten bietet die Kollektion auch die Möglichkeit, auf Anfrage maßgeschneiderte Abmessungen zu realisieren – für maximale gestalterische Freiheit und eine perfekte Integration in jedes architektonische Konzept.

Makro Project est une collection développée pour répondre aux exigences spécifiques des secteurs contract, hospitality et de l'aménagement nautique. Son objectif est d'offrir des solutions fiables, polyvalentes et performantes, capables de s'adapter à des environnements à fort passage et à des projets requérant des standards qualitatifs élevés. En complément des formats disponibles au catalogue, la gamme propose également la réalisation de dimensions personnalisées sur demande, garantissant ainsi une liberté créative maximale et une intégration parfaite dans chaque concept architectural.

<p>All'interno della serie Makro Project, i nuovi prodotti Bambù, Bambù Black, Black Wood e Radica reinterpretano in chiave ceramica l'eleganza della radica naturale, materiale pregiato utilizzato da sempre in ambiti realizzativi ad alto profilo come l'arredamento nautico, l'hotellerie e l'automotive di lusso.</p>	<p>Within the Makro Project collection, the new products Bambù, Bambù Black, Black Wood, and Radica reinterpret the elegance of reconstituted woods and natural burl in ceramic form—precious materials historically used in high-end sectors such as nautical furniture, hospitality, and luxury automotive design.</p>	<p>Innerhalb der Serie Makro Project interpretieren die neuen Produkte Bambù, Bambù Black, Black Wood und Radica die Eleganz rekonstruierter Hölzer und natürlicher Wurzelmaserungen in keramischer Form neu. Edle Materialien, die seit jeher in hochwertigen Anwendungsbereichen wie Yachtbau, Hotellerie und Luxusautomobilbau geschätzt werden.</p>	<p>Au sein de la série Makro Project, les nouveaux produits Bambù, Bambù Black, Black Wood et Radica réinterprètent en céramique l'élégance des bois recomposés et de la ronce naturelle, un matériau noble historiquement utilisé dans des réalisations haut de gamme telles que l'aménagement nautique, l'hôtellerie et l'automobile de luxe.</p>
--	--	---	---

4

Colori
Colours
Farben
Couleurs

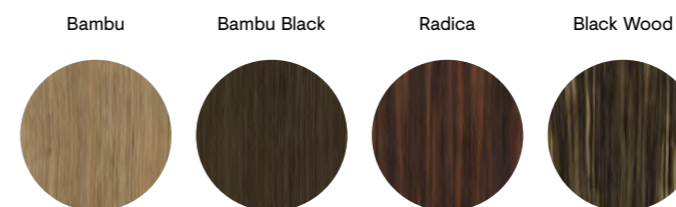

1

Formati
Sizes
Formate
Formats

120×280
48"×110"



2

Superfici
Surfaces
Oberflächen
Surfaces

Satin

Levigato

i

Effetto Contemporaneo
Contemporary effect
Moderne Wirkung
Effet Contemporain

Rivestimento
Wall Tiles
Wandfliesen
Revêtement

Pavimento
Floor Tiles
Bodenfliesen
Sol

Gres fine porcellanato ad impasto colorato
Coloured-body fine porcelain stoneware
Feinsteinzeug aus farbiger Masse
Grès cérame fin à pâte colorée

Tecnologia digitale
Digital technology
Digital technologie
Technologie numérique

Ripresa grafica tra le diverse lastre rettificate contenuta entro le tolleranze previste dalla norma. Per un corretto allineamento si consiglia di utilizzare una fuga di 2 mm.
Graphic representation between the rectified tiles is contained within the tolerances provided by the standard. For a correct alignment it is recommended to use a 2 mm joint.
Grafische Darstellung zwischen den verschiedenen rektifizierten Platten innerhalb der in der Norm vorgesehenen Toleranzen. Für eine korrekte Anpassung wird eine Fuge von 2mm empfohlen.
Reproduction graphique entre les différents carreaux rectifiés dans les limites des tolérances prévues par la norme. Pour un alignement correct, il est recommandé d'utiliser joints de 2 mm.

Makro Project

Bambù



120x280

06366 | Bambù Satin/Ret

06369 | Bambù Lev/Ret

Abbinabilità - Matching - Passende Kombinatione - Coloris Compatibles

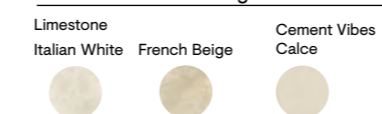



Makro Project

Contemporary
PREMIUM

Bambù Black



120x280

06394 | Bambù Black Satin/Ret
06395 | Bambù Black Lev/Ret

Abbinabilità - Matching - Passende Kombinatione - Coloris Compatibles

Limestone
English Grey



Cement Vibes
Beton



Makro Project

Radica

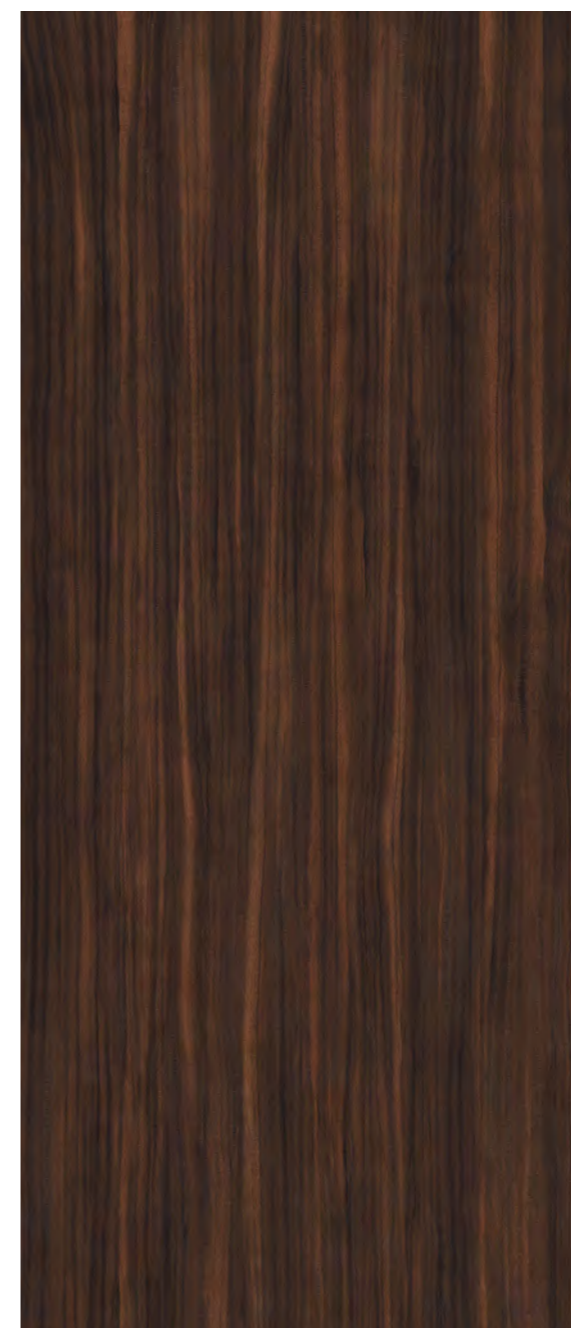

120x280

06364 | Radica Satin/Ret

06367 | Radica Lev/Ret

Abbinabilità - Matching - Passende Kombinatione - Coloris Compatibles

Cement Vibes
Calce Malta







Black Wood



120x280

06365 | Black Wood Satin/Ret
06368 | Black Wood Lev/Ret

Formati Sizes		
120x280 48"x110"		
± 6		
 Sat/Ret		06366
Bambù Lev/Ret		06369
 Sat/Ret		06394
Bambù Black Lev/Ret		06395
 Sat/Ret		06364
Radica Lev/Ret		06367
 Sat/Ret		06365
Black Wood Lev/Ret		06368

Abbinabilità - Matching

Passende Kombinatione - Coloris Compatibles

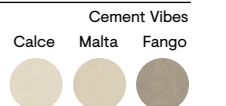

Formati Sizes	P	± MM	Pezzi Scatola Pieces/Box Stck/Karton Carreaux/Boîte	Mq/Scatola Sqmt/Box Qm/Karton M2/Boîte	Kg/Scatola Kgs/Box Kg/Karton Kg/Boîte	Scatole/Paletta Boxes/Pallet Karton/Palette Boîte/Palette	Mq/Paletta Sqmt/Pallet Qm/Pallet M2/Palette	Kg/Paletta Kgs/Pallet Kg/Pallet Kg/Palette	Formato Paletta Size Pallet Format Pallet Dim. Palette
120x280 (48"x110") Nat/Ret	P	6	1	3,36	46,50	20	67,20	930	143x294x35

Homey

La serie Homey è ispirata all'idea di ottenere superfici dall'aspetto naturale prendendo spunto dalla terra, nello specifico l'argilla con i suoi colori caldi e le sfumature 'ton sur ton' ottenendo una superficie morbida, ideale per una casa calda e confortevole.

The Homey series is inspired by the idea of obtaining natural-looking surfaces inspired by the earth, specifically clay with its warm colors and shades 'ton sur ton' obtaining a soft surface, ideal for a warm and cozy home.

Die Homey-Serie ist von der Idee inspiriert, natürlich aussehende Oberflächen zu erhalten, die sich von der Erde inspirieren lassen, insbesondere die Tonerde mit seinen warmen Farb- auf Farbtönen, um eine sanfte Oberfläche zu erhalten, die ideal für ein warmes und komfortables Zuhause ist.

La série Homey est inspirée par l'idée d'obtenir des surfaces à l'aspect naturel en s'inspirant de la terre, en particulier l'argile avec ses couleurs chaudes et les nuances 'ton sur ton' en obtenant une surface douce, idéale pour une maison chaude et confortable.

7

Colori
Colours
Farben
Couleurs

Chalk



Taupe



Cotto



Cloudy

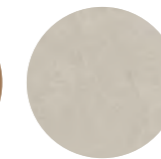

Dove



Sage

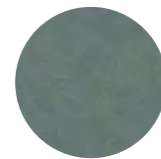

Berry



5

Formati
Sizes
Formate
Formats

120×280
48"×110"



120×120
48"×48"



60×120
24"×48"



60×60
24"×24"



10×60
4"×24"



4

Strutture 3D
3D structures
Strukturen
Décorations en relief

30×60
12"×24"



60×120
24"×48"



60×120
24"×48"



60×120
24"×48"



8

Colori
Colours
Farben
Couleurs

Stripes
Glossy

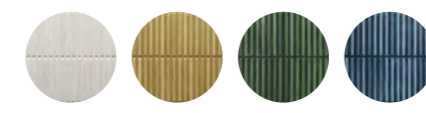

Stripes
Mat



6

Colori
Colours
Farben
Couleurs

Canneté
Mat

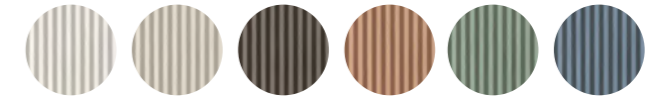

8

Colori
Colours
Farben
Couleurs

Paper Clay
Mat



5

Colori
Colours
Farben
Couleurs

Ramie
Mat

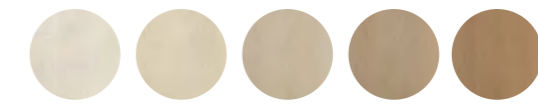

i

Effetto Contemporaneo
Contemporary effect
Moderne Wirkung
Effet Contemporain

Rivestimento
Wall Tiles
Wandfliesen
Revêtement

Pavimento
Floor Tiles
Bodenfliesen
Sol

Gres fine porcellanato ad impasto colorato
Coloured-body fine porcelain stoneware
Feinsteinzeug aus farbiger Masse
Grès cérame fin à pâte colorée

Tecnologia digitale
Digital technology
Digital technologie
Technologie numérique

Ripresa grafica tra le diverse lastre rettificate contenuta entro le tolleranze previste dalla norma. Per un corretto allineamento si consiglia di utilizzare una fuga di 2 mm.
Graphic representation between the rectified tiles is contained within the tolerances provided by the standard. For a correct alignment it is recommended to use a 2 mm joint.
Grafische Darstellung zwischen den verschiedenen rektifizierten Platten innerhalb der in der Norm vorgesehenen Toleranzen. Für eine korrekte Anpassung wird eine Fuge von 2mm empfohlen.
Reproduction graphique entre les différents carreaux rectifiés dans les limites des tolérances prévues par la norme. Pour un alignement correct, il est recommandé d'utiliser joints de 2 mm.

▶ WATCH THE VIDEO



Selezione Compasso d'Oro

Homey Paper Clay

Designed by Paola Paronetto

L'eccellenza dell'Artigianalità Italiana trova la sua massima espressione nella collezione Homey Paper Clay nata dalla collaborazione con l'artista Paola Paronetto. La serie getta un ponte tra il nostro mondo industriale e la tradizione della ceramica artistica, offrendo un'esperienza sensoriale avvolgente grazie a un gioco di riflessi e ombre creato dalle sue superfici dinamiche e fluide.

The excellence of Italian craftsmanship finds its maximum expression in the new collection Homey Paper Clay, created in collaboration with artist Paola Paronetto. The series bridges the gap between our industrial world and the tradition of artistic ceramics, offering an enveloping sensory experience through the interplay of reflections and shadows produced by its dynamic and fluid surfaces.

Die Exzellenz italienischer Handwerkskunst findet ihren höchsten Ausdruck in der Kollektion Homey Paper Clay, die in Zusammenarbeit mit der Künstlerin Paola Paronetto entstanden ist. Die Serie verbindet unsere industrielle Welt mit der Tradition der künstlerischen Keramik und bietet ein umfassendes Sinneserlebnis durch ein Spiel von Reflexionen und Schatten, das von ihren dynamischen und fließenden Oberflächen erzeugt wird.

L'excellence de l'Artisanat Italien trouve sa plus haute expression dans la nouvelle collection Homey Paper Clay, née de la collaboration avec la célèbre artiste Paola Paronetto. Cette série crée un pont entre notre monde industriel et la tradition de la céramique artistique, offrant une expérience sensorielle enveloppante grâce à un jeu de reflets et d'ombres créé par ses surfaces dynamiques et fluides.

8

Colori
Colours
Farben
Couleurs

Paper Clay
Antracite



Paper Clay
Cipria



Paper Clay
Sabbia



Paper Clay
Neve

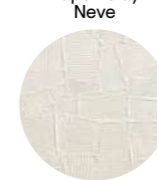

Paper Clay
Nuvola

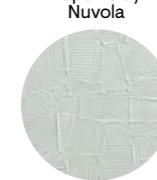

Paper Clay
Avio

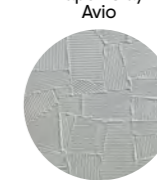

Paper Clay
Verde

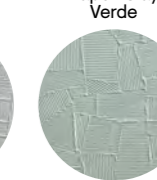

Paper Clay
Muschio

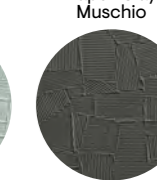

1

Formati
Sizes
Formate
Formats

60×120

24"×48"



1

Superfici
Surfaces
Oberflächen
Surfaces

Naturale

i

Effetto Contemporaneo
Contemporary effect
Moderne Wirkung
Effet Contemporain

Rivestimento
Wall Tiles
Wandfliesen
Revêtement

Pavimento
Floor Tiles
Bodenfliesen
Sol

Gres fine porcellanato ad impasto colorato
Coloured-body fine porcelain stoneware
Feinsteinzeug aus farbiger Masse
Grès cérame fin à pâte colorée

Tecnologia digitale
Digital technology
Digital technologie
Technologie numérique

Per ottenere una resa estetica ottimale delle piastrelle decorate, Piemme consiglia di effettuare una prova di posa a secco prima di procedere con l'installazione definitiva. Questa pratica consente di visualizzare il risultato finale, permettendo di valutare l'effetto complessivo e di apportare eventuali modifiche, come la disposizione o l'orientamento delle piastrelle, al fine di ottenere una composizione armoniosa.

To achieve the best aesthetic result for decorated tiles, Piemme recommends performing a dry-lay test before proceeding with the final installation. This practice allows you to preview the final result, enabling you to assess the overall effect and make any necessary adjustments, such as the arrangement or orientation of the tiles, to achieve a harmonious composition.

WATCH THE VIDEO



INDEX



INDEX

167



60x120
06076 | Homey Paper Clay Antracite Ret



60x120
06073 | Homey Paper Clay Nuvola Ret



60x120
06069 | Homey Paper Clay Cipria Ret

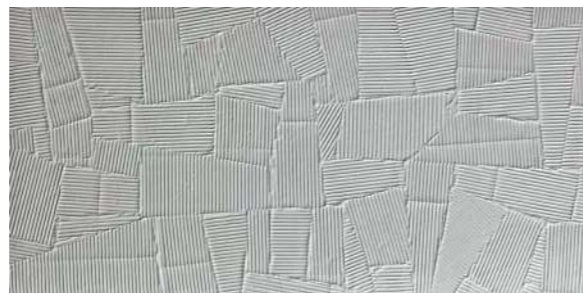

60x120
06072 | Homey Paper Clay Avio Ret



60x120
06070 | Homey Paper Clay Sabbia Ret



60x120
06071 | Homey Paper Clay Verde Ret



60x120
06074 | Homey Paper Clay Neve Ret

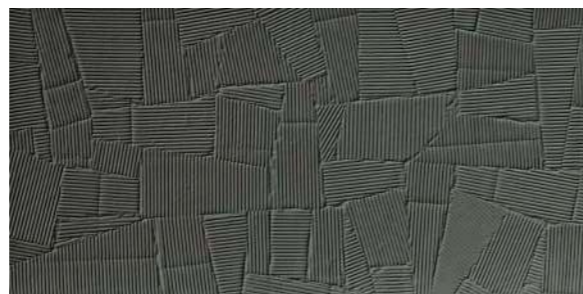

60x120
06075 | Homey Paper Clay Muschio Ret

Riepilogo Gamma

Abbinabilità

Collection
Serie
Gamme

Matching
Passende Kombinationen
Coloris Compatibles

PDF Merchandising

		Strutture 3D 3D Structures							
		Paper Clay Antracite 60x120 - 24"x48"	Paper Clay Cipria 60x120 - 24"x48"	Paper Clay Sabbia 60x120 - 24"x48"	Paper Clay Neve 60x120 - 24"x48"	Paper Clay Nuvola 60x120 - 24"x48"	Paper Clay Avio 60x120 - 24"x48"	Paper Clay Verde 60x120 - 24"x48"	Paper Clay Muschio 60x120 - 24"x48"
		€ 9,5	€ 9,5	€ 9,5	€ 9,5	€ 9,5	€ 9,5	€ 9,5	€ 9,5
	Nat/Ret	06076	06069	06070		06073	06072	06071	06075
	Nat/Ret		06069		06074				06075
	Nat/Ret				06074	06073			
	Nat/Ret	06076	06069	06070	06074				
	Nat/Ret		06069	06070	06074	06073	06072	06071	06075
	Nat/Ret				06074	06073			
	Nat/Ret				06074		06072		
Stucchi Consigliati Recommended grouts Joints recommandés Empfohlene Fugen		Kerakoll 10	Mapei 141	Kerakoll 86	Mapei 100	Mapei 103	Mapei 176	Mapei 177	Mapei 114

Homey Ramie

Texture naturale, ispirazione tessile, formato contemporaneo.
Con Homey Ramie, la struttura prende vita ispirandosi a un tessuto antico e nobile, il ramie, fibra naturale originaria dell'Estremo Oriente.

Natural texture, textile inspiration, contemporary format.
With Homey Ramie, structure comes to life, inspired by an ancient and noble fabric—ramie, a natural fiber originating from the Far East.

Natürliche Textur, textile Inspiration, zeitgemäßes Format.
Mit Homey Ramie erwacht die Struktur zum Leben – inspiriert von einem antiken und edlen Stoff, dem Ramie, einer Naturfaser aus dem Fernen Osten.

Texture naturelle, inspiration textile, format contemporain.
Avec Homey Ramie, la texture prend vie, inspirée d'un tissu ancien et noble : la ramie, une fibre naturelle originaire d'Extrême-Orient.

5

Colori
Colours
Farben
Couleurs

Ramie
Latte



Ramie
Crema



Ramie
Ecrù



Ramie
Terra



Ramie
Mattone



1

Formati
Sizes
Formate
Formats

60×120
24"×48"



1

Superfici
Surfaces
Oberflächen
Surfaces

Naturale

i

Effetto Contemporaneo
Contemporary effect
Moderne Wirkung
Effet Contemporain

Rivestimento
Wall Tiles
Wandfliesen
Revêtement

Gres fine porcellanato ad impasto colorato
Coloured-body fine porcelain stoneware
Feinsteinzeug aus farbiger Masse
Grès cérame fin à pâte colorée

Tecnologia digitale
Digital technology
Digital technologie
Technologie numérique

Per ottenere una resa estetica ottimale delle piastrelle decorate, Piemme consiglia di effettuare una prova di posa a secco prima di procedere con l'installazione definitiva. Questa pratica consente di visualizzare il risultato finale, permettendo di valutare l'effetto complessivo e di apportare eventuali modifiche, come la disposizione o l'orientamento delle piastrelle, al fine di ottenere una composizione armoniosa.

To achieve the best aesthetic result for decorated tiles, Piemme recommends performing a dry-lay test before proceeding with the final installation. This practice allows you to preview the final result, enabling you to assess the overall effect and make any necessary adjustments, such as the arrangement or orientation of the tiles, to achieve a harmonious composition.



60x120
06341 | Homey Ramie Latte Ret



60x120
06342 | Homey Ramie Crema Ret



60x120
06343 | Homey Ramie Ecrú Ret



60x120
06344 | Homey Ramie Terra Ret



60x120
06345 | Homey Ramie Mattone Ret

Riepilogo Gamma

Abbinabilità

Collection
Serie
Gamme

Matching
Passende Kombinationen
Coloris Compatibles

		Strutture 3D 3D Structures				
		Homey Ramie Latte 60x120 - 24"x48"	Homey Ramie Crema 60x120 - 24"x48"	Homey Ramie Ecrú 60x120 - 24"x48"	Homey Ramie Terra 60x120 - 24"x48"	Homey Ramie Mattone 60x120 - 24"x48"
		± 9,5	± 9,5	± 9,5	± 9,5	± 9,5
	Nat/Ret Chalk	06341	06342	06343	06344	06345
	Nat/Ret Taupe	06341	06342	06343	06344	06345
	Nat/Ret Cotto	06341	06342		06344	
	Nat/Ret Cloudy			06343		06345
	Nat/Ret Dove	06341		06343	06344	06345
	Nat/Ret Sage	06341	06342			06345
	Nat/Ret Berry	06341	06342			06345
Solonoce						
	Americano	06341	06342	06343	06344	06345
	Canaletto					
	Europeo					
Stucchi Consigliati Recommended grouts Joints recommandés Empfohlene Fugen		Mapei 103	Mapei 132	Mapei 189	Mapei 141	Kerakoll 155

Homey Canneté

La riscoperta della struttura cannettata, finitura 3D in auge tra gli anni '30 e '50, rielaborata in chiave moderna e declinata in diverse nuance.

The resurgence of a "Canneté" structure, a 3D finish popular in the 1930s and 1950s, reintroduced in a modern nuanced version.

Die Wiederentdeckung der Rattanstruktur, einer 3D-Oberflächenbearbeitung, die in den 1930er- bis 1950er-Jahren beliebt war, wurde auf moderne Weise neu interpretiert und in verschiedenen Nuancen in dem neuen dekorativen Vorschlag Homey Canneté umgesetzt.

La redécouverte de la structure cannetée, finition 3D en vogue entre les années 30 et 50, retravaillée de manière moderne et déclinée en différentes nuances.

6

Colori
Colours
Farben
Couleurs

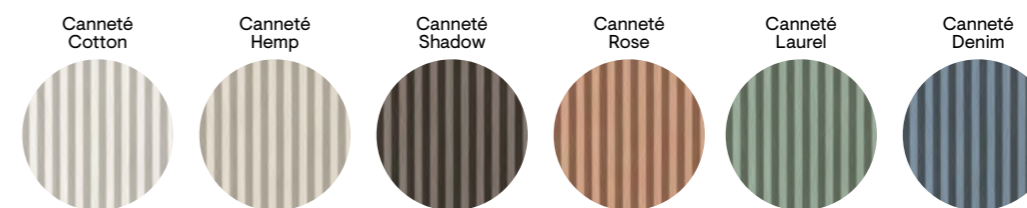

1

Formati
Sizes
Formate
Formats

60×120
24"×48"



1

Superfici
Surfaces
Oberflächen
Surfaces

Naturale

Per ottenere una resa estetica ottimale delle piastrelle decorate, Piemme consiglia di effettuare una prova di posa a secco prima di procedere con l'installazione definitiva. Questa pratica consente di visualizzare il risultato finale, permettendo di valutare l'effetto complessivo e di apportare eventuali modifiche, come la disposizione o l'orientamento delle piastrelle, al fine di ottenere una composizione armoniosa.

To achieve the best aesthetic result for decorated tiles, Piemme recommends performing a dry-lay test before proceeding with the final installation. This practice allows you to preview the final result, enabling you to assess the overall effect and make any necessary adjustments, such as the arrangement or orientation of the tiles, to achieve a harmonious composition.

i

Effetto Contemporaneo
Contemporary effect
Moderne Wirkung
Effet Contemporain

Rivestimento
Wall Tiles
Wandfliesen
Revêtement

Pavimento
Floor Tiles
Bodenfliesen
Sol

Gres fine porcellanato ad impasto colorato
Coloured-body fine porcelain stoneware
Feinsteinzeug aus farbiger Masse
Grès cérame fin à pâte colorée

Tecnologia digitale
Digital technology
Digital technologie
Technologie numérique

Ripresa grafica tra le diverse lastre rettificata contenuta entro le tolleranze previste dalla norma. Per un corretto allineamento si consiglia di utilizzare una fuga di 2 mm. Graphic representation between the rectified tiles is contained within the tolerances provided by the standard. For a correct alignment it is recommended to use a 2 mm joint. Grafische Darstellung zwischen den verschiedenen rektifizierten Platten innerhalb der in der Norm vorgesehenen Toleranzen. Für eine korrekte Anpassung wird eine Fuge von 2mm empfohlen. Reproduction graphique entre les différents carreaux rectifiés dans les limites des tolérances prévues par la norme. Pour un alignement correct, il est recommandé d'utiliser joints de 2 mm.



60x120
05981 | Homey Cannelé Cotton Ret



60x120
05983 | Homey Cannelé Rose Ret



60x120
05982 | Homey Cannelé Hemp Ret



60x120
05984 | Homey Cannelé Laurel Ret



60x120
05986 | Homey Cannelé Shadow Ret



60x120
05985 | Homey Cannelé Denim Ret

Riepilogo Gamma

Abbinabilità

Collection
Serie
Gamme

Matching
Passende Kombinationen
Coloris Compatibles

	Strutture 3D 3D Structures					
	Cannelé Cotton 60x120 24"x48"	Cannelé Hemp 60x120 24"x48"	Cannelé Shadow 60x120 24"x48"	Cannelé Rose 60x120 24"x48"	Cannelé Laurel 60x120 24"x48"	Cannelé Denim 60x120 24"x48"
	± 9,5	± 9,5	± 9,5	± 9,5	± 9,5	± 9,5
Nat/Ret Chalk		05982	05986	05983	05984	05985
Nat/Ret Taupe	05981				05984	05985
Nat/Ret Cotto	05981	05982			05984	05985
Nat/Ret Cloudy			05986			05985
Nat/Ret Dove	05981			05983		
Nat/Ret Sage	05981					
Nat/Ret Berry	05981	05982				

Stucchi Consigliati
Recommended grouts
Joints recommandés
Empfohlene Fugen

Mapei 103	Mapei 123	Mapei 114	Mapei 145	Kerakoll KK 50	50% Kerakoll KK 29 50% Kerakoll KK 30
-----------	-----------	-----------	-----------	----------------	--

Per ottenere una resa estetica ottimale delle piastrelle decorate, Piemme consiglia di effettuare una prova di posa a secco prima di procedere con l'installazione definitiva. Questa pratica consente di visualizzare il risultato finale, permettendo di valutare l'effetto complessivo e di apportare eventuali modifiche, come la disposizione o l'orientamento delle piastrelle, al fine di ottenere una composizione armoniosa.

To achieve the best aesthetic result for decorated tiles, Piemme recommends performing a dry-lay test before proceeding with the final installation. This practice allows you to preview the final result, enabling you to assess the overall effect and make any necessary adjustments, such as the arrangement or orientation of the tiles, to achieve a harmonious composition.

Homey Stripes

Dall'argilla, pressata in forme stabilite, asciugata e cotta vengono creati i laterizi di vari ornamenti architettonici utilizzati in edilizia. La collezione Homey trae ispirazione da queste forme di laterizio e propone una struttura a mattoncini sia in versione naturale che smaltata lucida.

From the clay, pressed in established forms, then dried and fired, are created the bricks of various architectural ornaments used in construction. The Homey collection draws inspiration from these brick shapes and presents a structure in both natural and glossy finish.

Die Homey-Kollektion ist von diesen Ziegelformen inspiriert und bietet eine Ziegelstruktur sowohl in natürlicher als auch in glänzend glasierter Ausführung.

La collection Homey s'inspire de ces formes de briques et propose une structure en briques aussi bien en version naturelle qu'en émail brillant.

8

Colori
Colours
Farben
Couleurs

Stripes
White Glossy



Stripes
Mustard Glossy

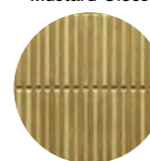

Stripes
Green Glossy

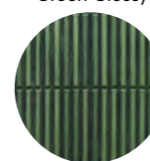

Stripes
Blue Glossy

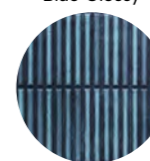

Stripes
White Matt



Stripes
Powder Matt



Stripes
Clay Matt



Stripes
Grey Matt



1

Formati
Sizes
Formate
Formats

30×60

12"×24"



1

Superfici
Surfaces
Oberflächen
Surfaces

Naturale

i

Effetto Contemporaneo
Contemporary effect
Moderne Wirkung
Effet Contemporain

Rivestimento
Wall Tiles
Wandfliesen
Revêtement

Pavimento
Floor Tiles
Bodenfliesen
Sol

Gres fine porcellanato ad impasto colorato
Coloured-body fine porcelain stoneware
Feinsteinzeug aus farbiger Masse
Grès cérame fin à pâte colorée

Tecnologia digitale
Digital technology
Digital technologie
Technologie numérique

Per ottenere una resa estetica ottimale delle piastrelle decorate, Piemme consiglia di effettuare una prova di posa a secco prima di procedere con l'installazione definitiva. Questa pratica consente di visualizzare il risultato finale, permettendo di valutare l'effetto complessivo e di apportare eventuali modifiche, come la disposizione o l'orientamento delle piastrelle, al fine di ottenere una composizione armoniosa.

To achieve the best aesthetic result for decorated tiles, Piemme recommends performing a dry-lay test before proceeding with the final installation. This practice allows you to preview the final result, enabling you to assess the overall effect and make any necessary adjustments, such as the arrangement or orientation of the tiles, to achieve a harmonious composition.

WATCH THE VIDEO

Stripes Glossy



30x60
05234 | Stripes White Glossy Ret



30x60
05235 | Stripes Mustard Glossy Ret

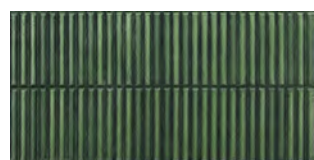

30x60
05233 | Stripes Green Glossy Ret



30x60
05232 | Stripes Blue Glossy Ret

Stripes Mat



30x60
05236 | Stripes White Mat Ret

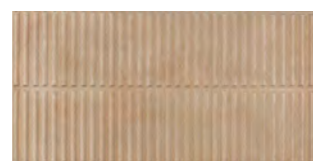

30x60
05237 | Stripes Powder Mat Ret

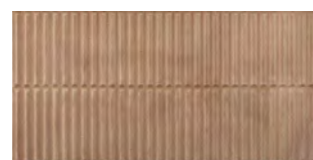

30x60
05238 | Stripes Clay Mat Ret



30x60
05239 | Stripes Grey Mat Ret

Riepilogo Gamma

Abbinabilità

Collection
Serie
Gamme

Matching
Passende Kombinationen
Coloris Compatibles

		Strutture 3D 3D Structures							
		Stripes White Glossy 30x60 12"x24"	Stripes Mustard Glossy 30x60 12"x24"	Stripes Green Glossy 30x60 12"x24"	Stripes Blue Glossy 30x60 12"x24"	Stripes White Mat 30x60 12"x24"	Stripes Powder Mat 30x60 12"x24"	Stripes Clay Mat 30x60 12"x24"	Stripes Grey Mat 30x60 12"x24"
		€ 9,5	€ 9,5	€ 9,5	€ 9,5	€ 9,5	€ 9,5	€ 9,5	€ 9,5
	Nat/Ret Chalk			05233	05232			05238	05239
	Nat/Ret Taupe	05234	05235	05233	05232	05236			
	Nat/Ret Cotto	05234		05233	05232		05237	05238	
	Nat/Ret Cloudy				05232	05236			05239
	Nat/Ret Dove	05234	05235			05236			
	Nat/Ret Sage	05234				05236		05238	
	Nat/Ret Berry	05234	05235			05236	05237	05238	
Stucchi Consigliati Recommended grouts Joints recommandés Empfohlene Fugen		Mapei 111	Kerakoll KK 102	Mapei 174	Kerakoll KK 30	Mapei 111	Mapei 141	Kerakoll KK 155	Mapei 112

Homey

Chalk

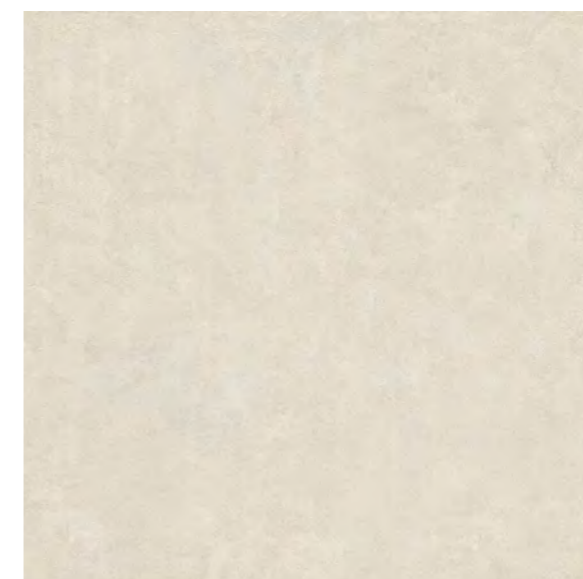

120x120
05245 | Homey Chalk Nat/Ret

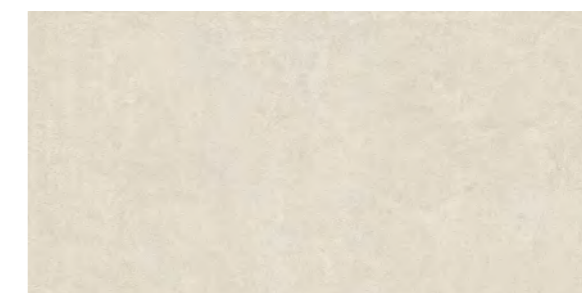

60x120
05216A | Homey Chalk Nat/Ret

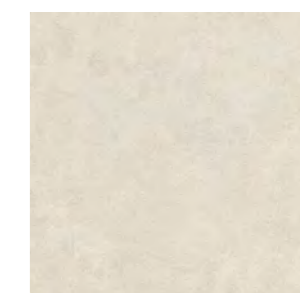

60x60
05224 | Homey Chalk Nat/Ret

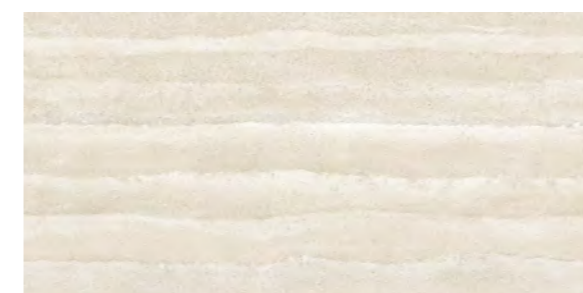

60x120
***05243A** | Homey Rammed Cold Nat/Ret
(mix 9 graphics)



60x120
05276A | Homey Bloom White Nat/Ret
(mix 6 graphics)



10x60 - 4"x24"
05277 | Homey Chalk Nat/Ret



60x120
***05244A** | Homey Rammed Warm Nat/Ret
(mix 9 graphics)

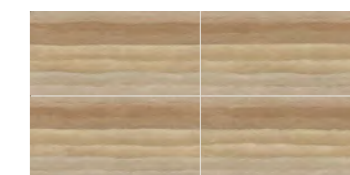

Posa corretta / Correct laying

* Per la continuità di posa, si consiglia il verso della grafica come da minimale a catalogo
For continuity of installation, we recommend the direction of the graphics as per picture in the catalogue
Für eine kontinuierliche Verlegung empfehlen wir die Verlegung gemäß der Abbildung im Katalog
Pour la continuité de l'installation, nous recommandons la direction des graphiques selon les détournés du catalogue

Homey

Taupe



120x120
05248 | Homey Taupe Nat/Ret

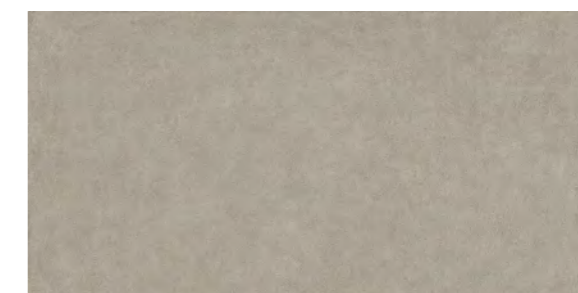

60x120
05219A | Homey Taupe Nat/Ret

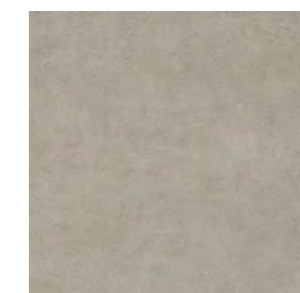

60x60
05227 | Homey Taupe Nat/Ret

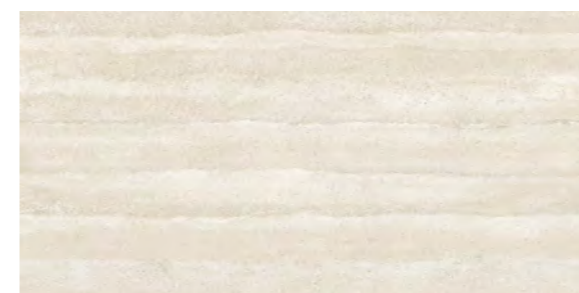

60x120
*05243A | Homey Rammed Cold Nat/Ret
(mix 9 graphics)

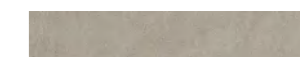

10x60
05280 | Homey Taupe Nat/Ret



60x120
05275A | Homey Bloom Blue Nat/Ret
(mix 6 graphics)

* Per la continuità di posa, si consiglia il verso della grafica come da minimale a catalogo
For continuity of installation, we recommend the direction of the graphics as per picture in the catalogue
Für eine kontinuierliche Verlegelinie empfehlen wir die Verlegung gemäß der Abbildung im Katalog
Pour la continuité de l'installation, nous recommandons la direction des graphiques selon les détournés du catalogue

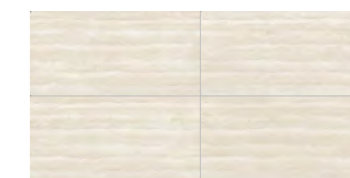

Posa corretta / Correct laying



INDEX

Pezzi speciali
Special pieces

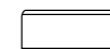

Battiscopa 4,5x60

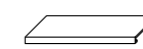

Gradino Costa Retta 33x120



INDEX

Homey

Cotto



60×60
05228 | Homey Cotto Nat/Ret



10×60
05281 | Homey Cotto Nat/Ret



120×120
05249 | Homey Cotto Nat/Ret

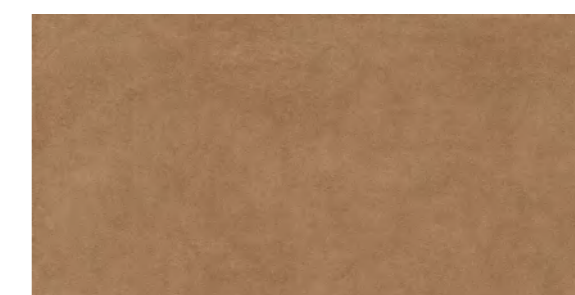

60×120
05221A | Homey Cotto Nat/Ret

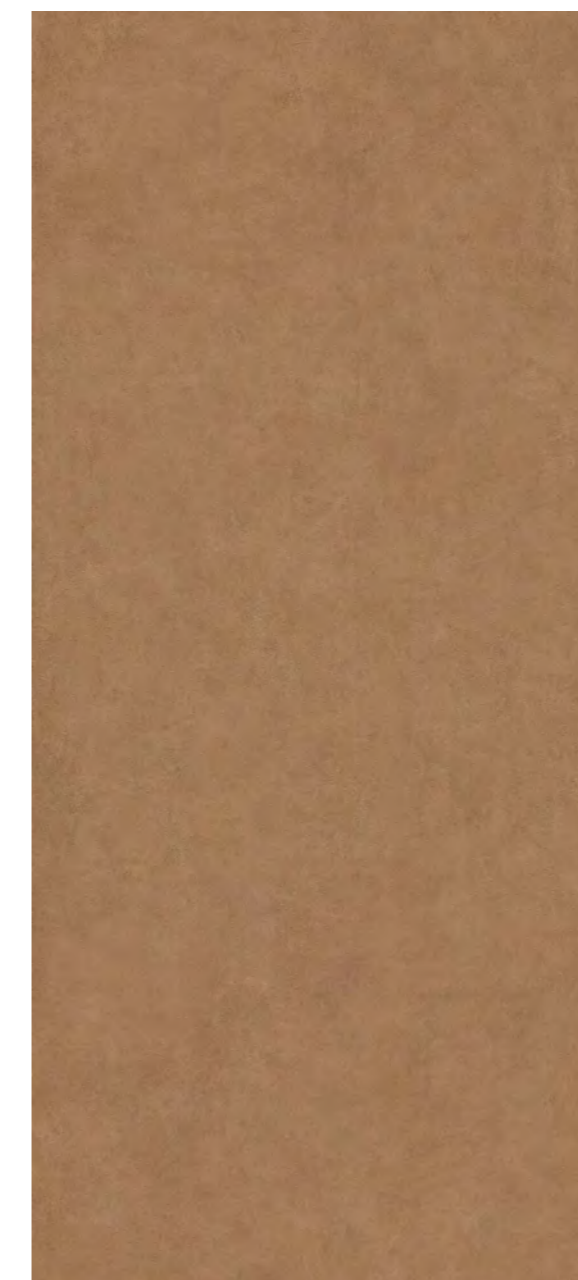

120×280
06231 | Homey Cotto Nat/Ret



60×120
05241A | Homey Flower Cotto Nat/Ret



60×120
*05244A | Homey Rammed Warm Nat/Ret (mix 9 graphics)
* Per la continuità di posa, si consiglia il verso della grafica come da minimale a catalogo
For continuity of installation, we recommend the direction of the graphics as per picture in the catalogue
Für eine kontinuierliche Verlegelinie empfehlen wir die Verlegung gemäß der Abbildung im Katalog
Pour la continuité de l'installation, nous recommandons la direction des graphiques selon les détours du catalogue

Homey

Cloudy

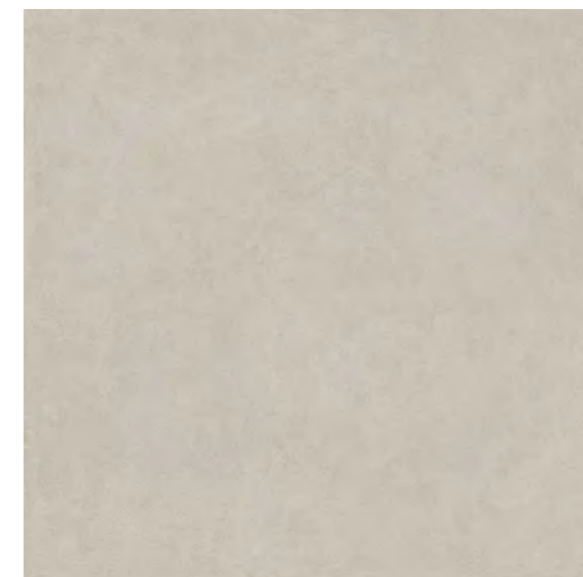

120x120
05246 | Homey Cloudy Nat/Ret

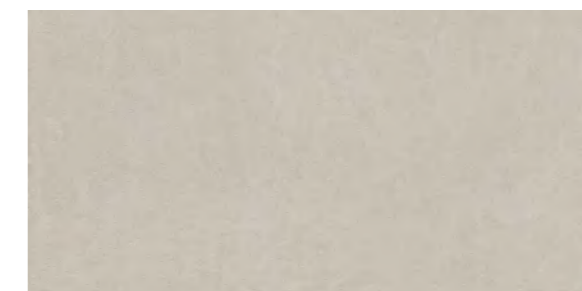

60x120
05217A | Homey Cloudy Nat/Ret



60x60
05225 | Homey Cloudy Nat/Ret

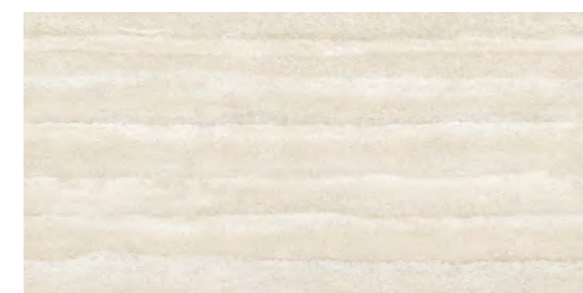

60x120
***05243A** | Homey Rammed Cold Nat/Ret
(mix 9 graphics)

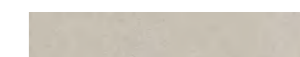

10x60
05278 | Homey Cloudy Nat/Ret



60x120
05275A | Homey Bloom Blue Nat/Ret
(mix 6 graphics)

* Per la continuità di posa, si consiglia il verso della grafica come da minimale a catalogo
For continuity of installation, we recommend the direction of the graphics as per picture in the catalogue
Für eine kontinuierliche Verlegung empfehlen wir die Verlegung gemäß der Abbildung im Katalog
Pour la continuité de l'installation, nous recommandons la direction des graphiques selon les détournés du catalogue

Homey

Dove

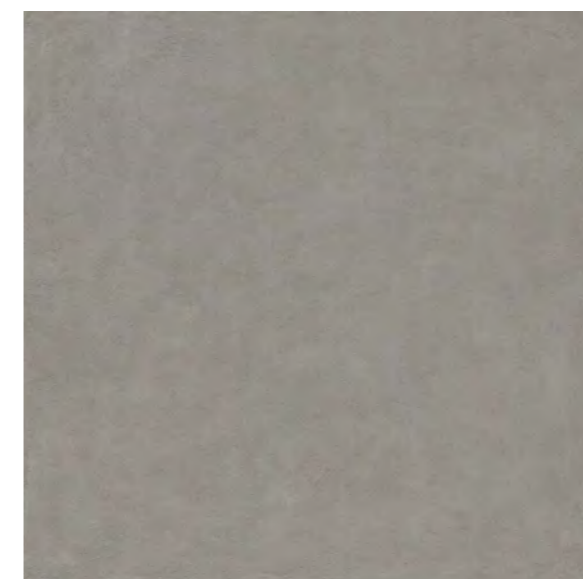

120x120
05247 | Homey Dove Nat/Ret

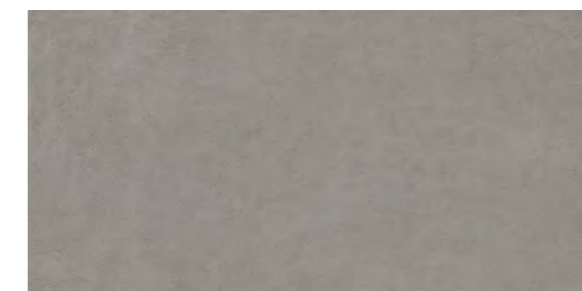

60x120
05218A | Homey Dove Nat/Ret

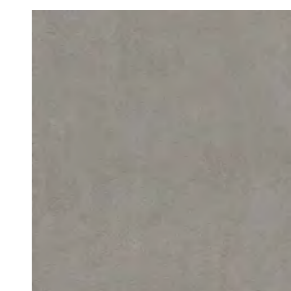

60x60
05226 | Homey Dove Nat/Ret

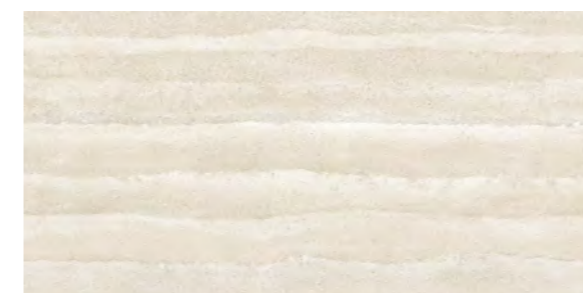

60x120
***05243A** | Homey Rammed Cold Nat/Ret
(mix 9 graphics)



10x60
05279 | Homey Dove Nat/Ret



60x120
05242A | Homey Flower Chalk Nat/Ret

* Per la continuità di posa, si consiglia il verso della grafica come da minimale a catalogo
For continuity of installation, we recommend the direction of the graphics as per picture in the catalogue
Für eine kontinuierliche Verlegung empfehlen wir die Verlegung gemäß der Abbildung im Katalog
Pour la continuité de l'installation, nous recommandons la direction des graphiques selon les détournés du catalogue

Homey

Sage



120×280
06230 | Homey Sage Nat/Ret

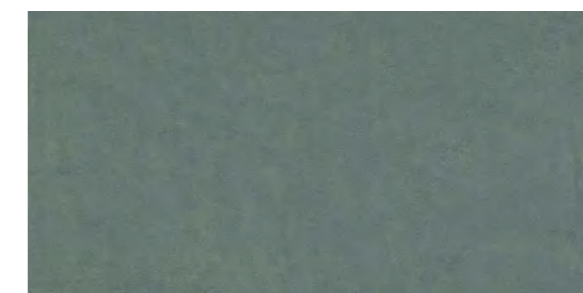

60×120
05222A | Homey Sage Nat/Ret

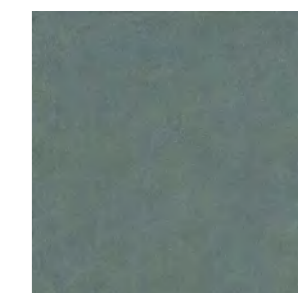

60×60
05229 | Homey Sage Nat/Ret



60×120
05276A | Homey Bloom White Nat/Ret
(mix 6 graphics)



10×60
05282 | Homey Sage Nat/Ret

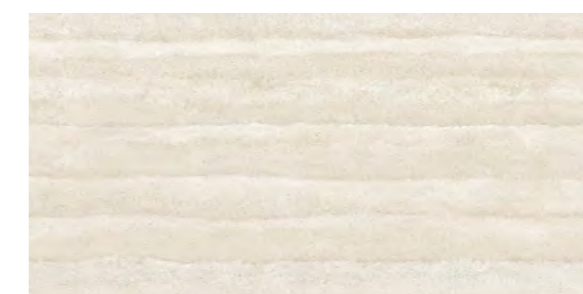

60×120
***05243A** | Homey Rammed Cold Nat/Ret
(mix 9 graphics)



Berry



120x280
06229 | Homey Berry Nat/Ret



60x120
05223A | Homey Berry Nat/Ret

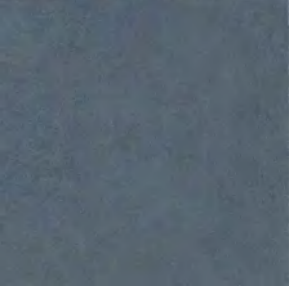

60x60
05231 | Homey Berry Nat/Ret



60x120
05241A | Homey Flower Cotto Nat/Ret



10x60
05283 | Homey Berry Nat/Ret

Imballi

Packing
Verpackung
Emballage

Formati Sizes	P	± MM	Pezzi Scatola Pieces/Box Stck/Karton Carreaux/Boîte		Mq/Scatola Sqmt/Box Qm/Karton M2/Boîte		Kg/Scatola Kgs/Box Kg/Karton Kg/Boîte		Scatole/Paletta Boxes/Pallet Karton/Palette Boîte/Palette		Mq/Paletta Sqmt/Pallet Qm/Pallet M2/Palette		Kg/Paletta Kgs/Pallet Kg/Pallet Kg/Palette		Formato Paletta Size Pallet Format Pallet Dim. Palette	
			1	3,36	46,50	20	67,20	930	143x294x35							
120x280 (48"x110") Nat/Ret	P	6	1	3,36	46,50	20	67,20	930	143x294x35							
120x120 (48"x48") Nat/Ret	P	9,5	2	2,880	58,00	22	63,36	1276,00	135x122x68							
60x120 (24"x48") Nat/Ret (A)	P	9,5	2	1,440	31,00	36	51,84	1116,00	122x95x76							
60x120 (24"x48") Ramie	P	9,5	2	1,44	31,00	36	51,84	1116,00	122x95x76							
60x120 (24"x48") Paper Clay	P	9,5	2	1,440	28,50	36	51,84	1026	122x95x76							
60x120 (24"x48") Cannetè Ret	P	9,5	1	0,720	16,00	60	43,20	960	122x95x76							
60x60 (24"x24") Nat/Ret	P	9,5	4	1,440	29,00	32	46,08	928,00	120x80x75							
10x60 (4"x24") Nat/Ret	P	9,5	10	0,600	12,50	72	43,20	900,00	120x80x75							
30x60 (12"x24") Stripes Nat/Ret	P	9,5	7	1,260	26,30	32	40,32	841,60	120x80x75							
60x120 (24"x48") Rammed Nat/Ret (A)	P	9,5	2	1,440	31,00	36	51,84	1116	122x95x76							
60x120 (24"x48") Bloom Nat/Ret (A)	P	9,5	2	1,440	31,00	36	51,84	1116	122x95x76							
60x120 (24"x48") Flower Nat/Ret (A)	P	9,5	2	1,440	31,00	36	51,84	1116	122x95x76							
Pezzi Speciali / Special Pieces																
33x120 (13"x48") Gradino Costa Retta Nat/Ret	P	9,5	2	0,792	18,50	20	-	-	-							
4,5x60 (1½"x24") Battiscopa Nat/Ret	P	9,5	14	0,378 m.l. 8,40	8,00	80	-	-	-							

Riepilogo Gamma

Abbinabilità

Collection
Serie
Gamme

Matching
Passende Kombinationen
Coloris Compatibles

PDF Merchandising

Colori Colors Couleurs	Formati Sizes	P	± MM	Pezzi Scatola Pieces/Box Stck/Karton Carreaux/Boîte		Mq/Scatola Sqmt/Box Qm/Karton M2/Boîte		Kg/Scatola Kgs/Box Kg/Karton Kg/Boîte		Scatole/Paletta Boxes/Pallet Karton/Palette Boîte/Palette		Mq/Paletta Sqmt/Pallet Qm/Pallet M2/Palette		Kg/Paletta Kgs/Pallet Kg/Pallet Kg/Palette		Formato Paletta Size Pallet Format Pallet Dim. Palette		Pezzi Speciali Special Pieces		Stucchi Consigliati Recommended grouts Joints recommandés Empfohlene Fugen
				1	3,36	46,50	20	67,20	930	143x294x35										
Chalk	120x120 (48"x48") Nat/Ret	P	9,5	2	2,880	58,00	22	63,36	1276,00	135x122x68										Mapei 111
Taupe	120x120 (48"x48") Nat/Ret	P	9,5	2	2,880	58,00	22	63,36	1276,00	135x122x68										50% Mapei 111 50% Mapei 112
Cotto	60x120 (24"x48") Nat/Ret	P	9,5	2	1,440	31,00	36	51,84	1116,00	122x95x76										Mapei 142
Cloudy	60x120 (24"x48") Nat/Ret	P	9,5	2	1,440	31,00	36	51,84	1116,00	122x95x76										Mapei 111
Dove	60x120 (24"x48") Nat/Ret	P	9,5	2	1,440	31,00	36	51,84	1116,00	122x95x76										Mapei 112
Sage	60x120 (24"x48") Nat/Ret	P	9,5	2	1,440	31,00	36	51,84	1116,00	122x95x76										Kerakoll 50
Berry	60x120 (24"x48") Nat/Ret	P	9,5	2	1,440	31,00	36	51,84	1116,00	122x95x76										Kerakoll 30

Kerakoll 34	Mapei 111	Mapei 133	Mapei 111	Mapei 111	Kerakoll 14
-------------	-----------	-----------	-----------	-----------	-------------

Stucchi Consigliati
Recommended grouts
Joints recommandés
Empfohlene Fugen



Materia

Materia nasce dall'idea sviluppata in Piemme per una nuova espressione della ceramica, una materia nobile con una grande storia creativa che ritrova e rilancia il proprio estro originario e, grazie alla sua tecnica grafica, analizza l'estetica di materie differenti, come il metallo, la pietra e la ceramica stessa.

Materia is conceived to introduce a new expression of ceramics. A noble material with a great history relaunches its creative potential thanks to the graphic technique and the diverse esthetics of materials like metal, stone and ceramics itself.

Mit „Materia“ möchte Piemme der Keramik einen neuen Ausdruck verleihen. Das edle und geschichtsträchtige Material findet zurück zu seinen Wurzeln, erfindet sich neu und analysiert mit seiner graphischen Technik seine eigene Ästhetik sowie die anderer Materialien wie Metall und Stein.

« Materia » est l'aboutissement d'une idée développée par Piemme: donner à la céramique, matière noble, riche d'une histoire nourrie de créativité, une nouvelle forme d'expression où elle puisse retrouver son style originel. Ses techniques graphiques lui permettent d'analyser les dimensions esthétiques de matières comme le métal, la pierre ainsi que la céramique.

6

Colori
Colours
Farben
Couleurs

Opal



Shimmer



Nacre



Reflex



Rust

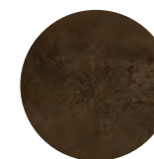

Deep



4

Formati
Sizes
Formate
Formats

120×120
48"×48"



60×120
24"×48"



60×60
24"×24"



30×60
12"×24"



2

Superfici
Surfaces
Oberflächen
Surfaces

Naturale

Lappato

2

Strutture 3D
3D structures
Strukturen
Decorations and relief

Tensegrity



Garage

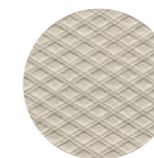

i

Effetto Contemporaneo
Contemporary effect
Moderne Wirkung
Effet Contemporain

Rivestimento
Wall Tiles
Wandfliesen
Revêtement

Pavimento
Floor Tiles
Bodenfliesen
Sol

Gres fine porcellanato ad impasto colorato
Coloured-body fine porcelain stoneware
Feinsteinzeug aus farbiger Masse
Grès cérame fin à pâte colorée

Tecnologia digitale
Digital technology
Digital Technologie
Technologie numérique

▶ WATCH THE VIDEO

Materia

Opal

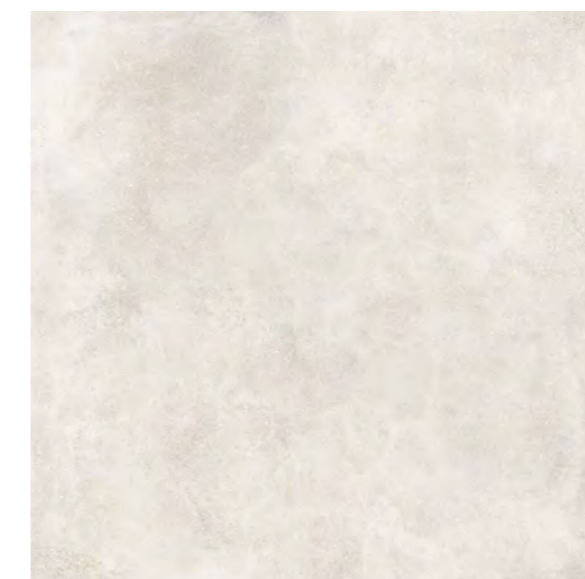

120x120
03071A | Materia Opal Nat/Ret
03075A | Materia Opal Lap/Ret



60x60
02847A | Materia Opal Nat/Ret
02853A | Materia Opal Lap/Ret



60x60
***02981A** | Materia Platinum Nat/Ret
(mix 4 graphics)

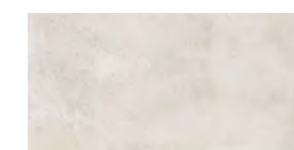

30x60
02827A | Materia Opal Nat/Ret
02834A | Materia Opal Lap/Ret

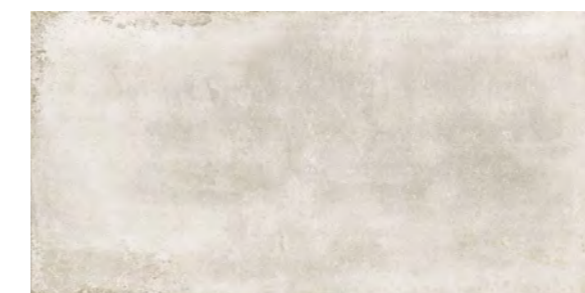

60x120
02859B | Materia Opal Nat/Ret
02866B | Materia Opal Lap/Ret

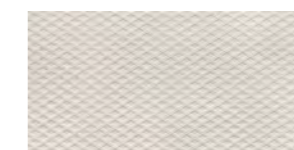

30x60
02936A | Materia Garage Opal Nat/Ret



30x120
***02944A** | Materia Raku Warm Nat/Ret
(handcrafted decor)

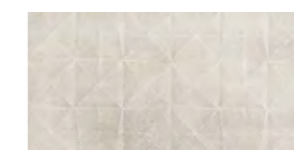

30x60
03079A | Materia Tensegrity Opal Nat/Ret

* Decori realizzati con smalti e metalli preziosi. Vedere nota a pag. 382-383.
Decors made with glazes and precious metals. See note on pages 382-383.
Dekore aus Glasuren und Edelmetallen. Siehe Hinweis auf Seiten 382-383.
Décors réalisés avec des émaux et des métaux précieux. Voir note aux pages 382-383.

Materia

Shimmer



120x120

03072A | Materia Shimmer Nat/Ret
03076A | Materia Shimmer Lap/Ret

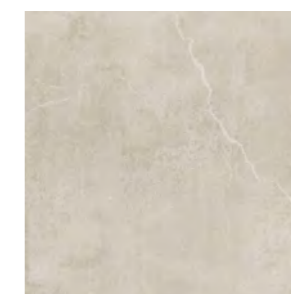

60x60

02849A | Materia Shimmer Nat/Ret
02855A | Materia Shimmer Lap/Ret

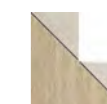

20x15

02989 | Soul Kaleido Light Nat/Ret

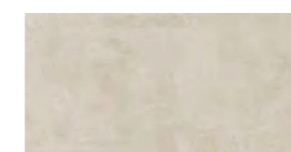

30x60

02829A | Materia Shimmer Nat/Ret
02838A | Materia Shimmer Lap/Ret

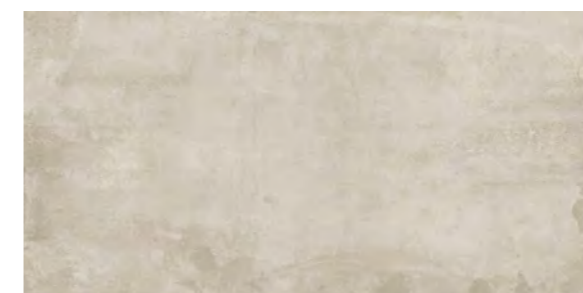

60x120

02862B | Materia Shimmer Nat/Ret
02868A | Materia Shimmer Lap/Ret

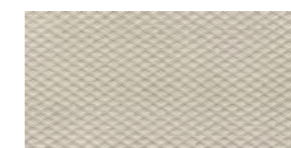

30x60

02938A | Materia Garage Shimmer Nat/Ret



30x120

***02944A** | Materia Raku Warm Nat/Ret
(handcrafted decor)



30x60

03082A | Materia Tensegrity Shimmer Nat/Ret

* Decori realizzati con smalti e metalli preziosi. Vedere nota a pag. 382-383
Decors made with glazes and precious metals. See note on pages 382-383
Dekore aus Glasuren und Edelmetallen. Siehe Hinweis auf Seiten 382-383
Décors réalisés avec des émaux et des métaux précieux. Voir note aux pages 382-383

Materia

Nacre



60x120
02861B | Materia Nacre Nat/Ret
02867A | Materia Nacre Lap/Ret



60x60
02848A | Materia Nacre Nat/Ret
02854A | Materia Nacre Lap/Ret



60x60
***02980A** | Materia Gold Nat/Ret
(mix 4 graphics)



30x120
***02944A** | Materia Raku Warm Nat/Ret
(handcrafted decor)

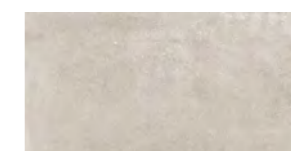

30x60
02828A | Materia Nacre Nat/Ret
02836A | Materia Nacre Lap/Ret

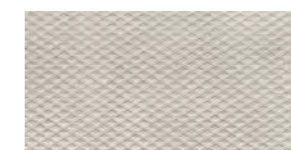

30x60
02937A | Materia Garage Nacre Nat/Ret

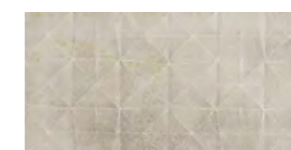

30x60
03081A | Materia Tensegrity Nacre Nat/Ret

* Decori realizzati con smalti e metalli preziosi. Vedere nota a pag. 382-383
Decors made with glazes and precious metals. See note on pages 382-383
Dekore aus Glasuren und Edelmetallen. Siehe Hinweis auf Seiten 382-383
Décors réalisés avec des émaux et des métaux précieux. Voir note aux pages 382-383



Reflex



60×120

02863A | Materia Reflex Nat/Ret
02869A | Materia Reflex Lap/Ret



60×60

02850A | Materia Reflex Nat/Ret
02856A | Materia Reflex Lap/Ret



30×120

***02944A** | Materia Raku Warm Nat/Ret
(handcrafted decor)



30×60

02831A | Materia Reflex Nat/Ret
02841A | Materia Reflex Lap/Ret

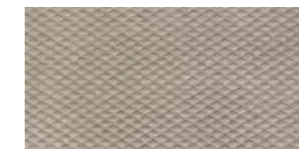

30×60

02939A | Materia Garage Reflex Nat/Ret

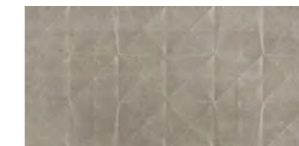

30×60

03083A | Materia Tensegrity Reflex Nat/Ret

* Decori realizzati con smalti e metalli preziosi. Vedere nota a pag. 382-383
Decors made with glazes and precious metals. See note on pages 382-383
Dekore aus Glasuren und Edelmetallen. Siehe Hinweis auf Seiten 382-383
Décors réalisés avec des émaux et des métaux précieux. Voir note aux pages 382-383

Materia

Rust



120x120

03073A | Materia Rust Nat/Ret
03077A | Materia Rust Lap/Ret



60x60

02851A | Materia Rust Nat/Ret
02857A | Materia Rust Lap/Ret



60x60

***02945A** | Materia Jade Nat/Ret
(mix 4 graphics)

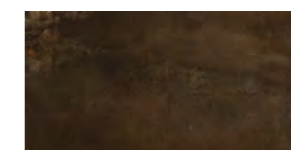

30x60

02832A | Materia Rust Nat/Ret
02843A | Materia Rust Lap/Ret



20x15

02990 | Soul Kaleido Dark Nat/Ret

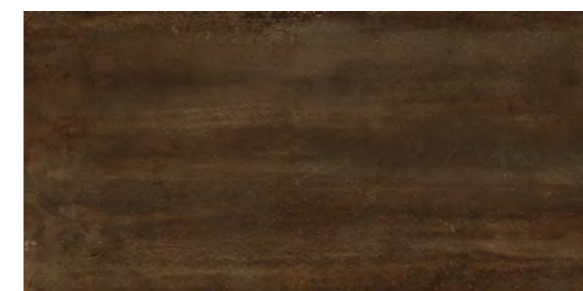

60x120

02864A | Materia Rust Nat/Ret
02871A | Materia Rust Lap/Ret

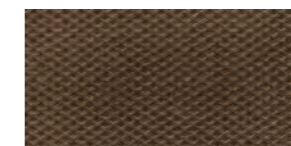

30x60

02941A | Materia Garage Rust Nat/Ret



30x120

***02944A** | Materia Raku Warm Nat/Ret
(handcrafted decor)

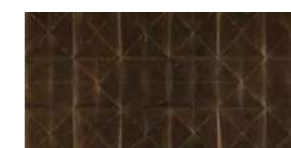

30x60

03084A | Materia Tensegrity Rust Nat/Ret

* Decori realizzati con smalti e metalli preziosi. Vedere nota a pag. 382-383
Decors made with glazes and precious metals. See note on pages 382-383
Dekore aus Glasuren und Edelmetallen. Siehe Hinweis auf Seiten 382-383
Décors réalisés avec des émaux et des métaux précieux. Voir note aux pages 382-383

Materia

Deep



120x120

03074A | Materia Deep Nat/Ret
03078A | Materia Deep Lap/Ret



60x60

02852A | Materia Deep Nat/Ret
02858A | Materia Deep Lap/Ret



60x60

***02946A** | Materia Zaphire Nat/Ret
(mix 4 graphics)

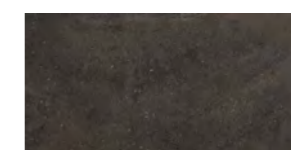

30x60

02833A | Materia Deep Nat/Ret
02846A | Materia Deep Lap/Ret

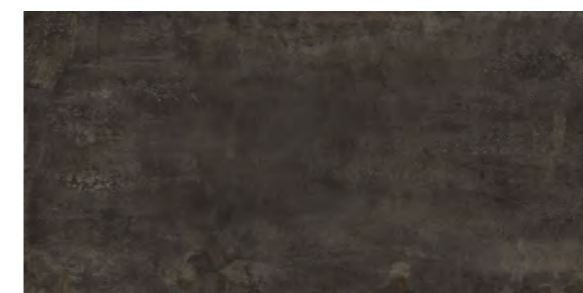

60x120

02865B | Materia Deep Nat/Ret
02872B | Materia Deep Lap/Ret



30x60

02942A | Materia Garage Deep Nat/Ret



30x120

***02943A** | Materia Raku Cold Nat/Ret
(handcrafted decor)

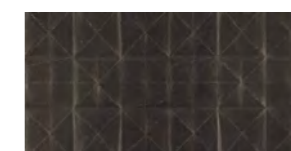

30x60

03085A | Materia Tensegrity Deep Nat/Ret

* Decori realizzati con smalti e metalli preziosi. Vedere nota a pag. 382-383
Decors made with glazes and precious metals. See note on pages 382-383
Dekore aus Glasuren und Edelmetallen. Siehe Hinweis auf Seiten 382-383
Décors réalisés avec des émaux et des métaux précieux. Voir note aux pages 382-383

Packing
Verpackung
Emballage











Formati Sizes	P	± MM						Formato Paletta Size Pallet Format Pallet Dim. Palette	
			Pezzi Scatola Pieces/Box Stck/Karton Carreaux/Boîte	Mq/Scatola Sqmt/Box Qm/Karton M2/Boîte	Kg/Scatola Kgs/Box Kg/Karton Kg/Boîte	Scatole/Paletta Boxes/Pallet Karton/Palette Boîte/Palette	Mq/Paletta Sqmt/Pallet Qm/Pallet M2/Palette		Kg/Paletta Kgs/Pallet Kg/Pallet Kg/Palette
120x120 (48"x48") Nat/Ret - Lap/Ret	P	9,5	2	2,88	58,00	22	63,36	1276	135x122x68
60x120 (24"x48") Nat/Ret - Lap/Ret (B)	P	9,5	2	1,44	31,00	36	43,20	930	122x82x75
60x120 (24"x48") Nat/Ret (A)	P	9,5	2	1,44	31,00	30	43,20	930	122x82x75
60x120 (24"x48") Lap/Ret (A)	P	9,5	2	1,44	32,00	30	43,20	960	122x82x75
60x60 (24"x24") Nat/Ret	P	9,5	4	1,44	29,00	32	46,08	928	120x80x75
60x60 (24"x24") Lap/Ret	P	9,5	4	1,44	30,00	32	46,08	960	120x80x75
30x60 (12"x24") Nat/Ret	P	9,5	7	1,26	25,30	40	50,4	1012	120x80x75
30x60 (12"x24") Lap/Ret	P	9,5	7	1,26	26,30	40	50,4	1052	120x80x75
30x120 (12"x48") Raku Nat/Ret	P	9,5	2	0,72	15,50	30	21,60	465	122x96x70
60x60 (24"x24") Jade - Zaphire - Gold - Platinum Nat/Ret	P	9,5	2	0,72	14,50	32	23,04	464	120x80x75
30x60 (12"x24") Garage Nat/Ret	P	9,5	7	1,26	25,30	32	40,32	809,6	120x80x75
30x60 (12"x24") Tensegrity Nat/Ret	P	9,5	7	1,26	25,30	32	40,32	809,6	120x80x75
20x15 (8"x6") Kaleido Nat/Ret	P	9,5	25	0,750	15,50	36	-	-	-
Pezzi Speciali / Special Pieces									
33x120 (13"x48") Gradino Costa Retta Nat/Ret - Lap/Ret	P	9,5	2	0,792	18,50	20	-	-	-
4,5x60 (1 1/2"x24") Battiscopa Nat/Ret - Lap/Ret	P	9,5	14	0,378	8,00	80	-	-	-

Collection
Serie
Gamme

Formati Sizes	P	± MM								
			120x120 48"x48"	60x120 24"x48"	60x60 24"x24"	30x60 12"x24"	EN 16165C	EN 16165A	DCOF	
			± 9,5	± 9,5	± 9,5	± 9,5				
	Nat/Ret		03071A	02859B	02847A	02827A	V2	R10	A+B	>0.42
	Lap/Ret		03075A	02866B	02853A	02834A				
	Nat/Ret		03072A	02862B	02849A	02829A	V2	R10	A+B	>0.42
	Lap/Ret		03076A	02868A	02855A	02838A				
	Nat/Ret			02861B	02848A	02828A	V2	R10	A+B	>0.42
	Lap/Ret			02867A	02854A	02836A				
	Nat/Ret			02863A	02850A	02831A	V2	R10	A+B	>0.42
	Lap/Ret			02869A	02856A	02841A				
	Nat/Ret		03073A	02864A	02851A	02832A	V2	R10	A+B	>0.42
	Lap/Ret		03077A	02871A	02857A	02843A				
	Nat/Ret		03074A	02865B	02852A	02833A	V2	R10	A+B	>0.42
	Lap/Ret		03078A	02872B	02858A	02846A				

Riepilogo Gamma

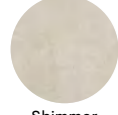
Collection
Serie
Gamme

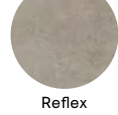
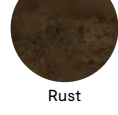
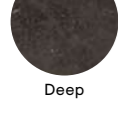
	Formati Sizes	Strutture 3D 3D Structures							
									
		Tensegrity 30×60 12"×24"	Garage 30×60 12"×24"	Platinum 60×60 24"×24"	Gold 60×60 24"×24"	Jade 60×60 24"×24"	Zaphire 60×60 24"×24"	Raku 30×120 12"×48"	Kaleido 20×15 8"×6"
		± 9,5	± 9,5	± 9,5	± 9,5	± 9,5	± 9,5	± 9,5	
 Opal	Nat/Ret	03079A	02936A	02981A				02944A	
 Shimmer	Nat/Ret	03082A	02938A					02944A	02989
 Nacre	Nat/Ret	03081A	02937A		02980A			02944A	
 Reflex	Nat/Ret	03083A	02939A					02944A	
 Rust	Nat/Ret	03084A	02941A			02945A		02944A	02990
 Deep	Nat/Ret	03085A	02942A				02946A	02943A	

Riepilogo Gamma

Collection
Serie
Gamme

	Formati Sizes	Pezzi Speciali Special Pieces	
			
		Gradino Costa Retta 33×120 13"×48"	Battiscopa 4,5×60 1 3/4"×24"
		± 9,5	± 9,5
 Opal	Nat/Ret	03097A	02893
	Lap/Ret	03104A	02899
 Shimmer	Nat/Ret	03099A	02895
	Lap/Ret	03106A	02902
 Nacre	Nat/Ret	03098A	02894
	Lap/Ret	03105A	02901
 Reflex	Nat/Ret	03101A	02896
	Lap/Ret	03107A	02903
 Rust	Nat/Ret	03102A	02897
	Lap/Ret	03108A	02904
 Deep	Nat/Ret	03103A	02898
	Lap/Ret	03109A	02905

Fragments

Designed by Pierre Charpin

Proprio come i "frammenti di un discorso amoroso" la collezione disegnata da Pierre Charpin per Ceramiche Piemme insegue il movimento, non ha trama, se non quella dell'indagine sul linguaggio delle forme.

Just like the "fragments of a lover's discourse" the collection designed by Pierre Charpin for Ceramiche Piemme follows movement and has no plot except for the investigation into the language of shapes.

Ebenso wie die "fragmente einer sprache der liebe" folgt die von Pierre Charpin für Ceramiche Piemme entworfene kollektion der Bewegung, ohne feste Struktur ausser jener einer Untersuchung der Formensprache.

A la manière des "fragments d'un discours amoureux", la collection dessinée par Pierre Charpin pour Ceramiche Piemme épouse le mouvement ; elle n'a pas de trame si ce n'est l'analyse du langage des formes.

6

Colori
Colours
Farben
Couleurs

Maiolica Milk

Maiolica Cloud

Maiolica Tan

Maiolica Fern

Maiolica Ocean

Maiolica Charcoal

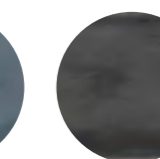
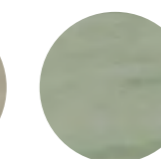
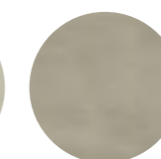
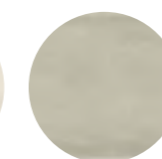

1

Formati
Sizes
Formate
Formats

7,5×30

3"×12"

1

1

Superfici
Surfaces
Oberflächen
Surfaces

Naturale

i

Effetto Contemporaneo
Contemporary effect
Moderne Wirkung
Effet Contemporain

Rivestimento
Wall Tiles
Wandfliesen
Revêtement

Pasta Bianca
White Body
Weißscherbisig
Pâte Blanche

Tecnologia digitale
Digital technology
Digital Technologie
Technologie numérique

Maiolica Milk



Maiolica Fern



Maiolica Cloud



Maiolica Ocean

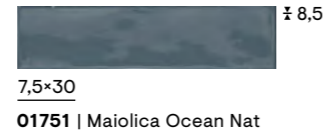

Maiolica Tan



Maiolica Charcoal



Imballi

Packing
Verpackung
Emballage

Formato / Size		± MM	Pezzi Scatola Pcs/Box Stck/Karton Carreaux/Boîtes	Mq/Scatola Sqmt/Box M2/Karton Qm/Boîtes	Kg/Scatola Kgs/Box Kg/Karton Kg/Boîtes	Scatola/Paletta Boxes/Pallet Karton/Palette Boîtes/Pallet	Mq/Paletta Sqmt/Pallet M2/Palette Qm/Pallet	Kg/Paletta Kgs/Pallet Kg/Palette Kg/Pallet	Formato Paletta Size Pallet Format Palette Dim. Palette
7,5x30 (3"x12") Nat	PB	8,5	22	0,50	7,29	120	60	875	120x80x75

Riepilogo Gamma

Collection
Serie
Gamme

	Formati Sizes	7,5x30 3"x12"	
		± 8,5	
	Nat	01746	V2
Milk			
	Nat	01747	V2
Cloud			
	Nat	01748	V2
Tan			
	Nat	01752	V2
Fern			
	Nat	01751	V2
Ocean			
	Nat	01749	V2
Charcoal			

Venetian Marble

Una collezione ispirata al terrazzo alla veneziana; utilizzato fin dall'antichità in Grecia ha poi raggiunto l'Italia con larga diffusione grazie agli antichi romani prima ed ai nobili veneziani poi.

A collection inspired by the Venetian terrazzo flooring used since ancient times in Greece. It then reached and became widespread in Italy, first of all thanks to the ancient Romans and then to the Venetian nobles.

Die Kollektion ist am venezianischen Terrazzoboden inspiriert, der bereits in der griechischen Antike bekannt war und dann in Italien weite Verbreitung fand - im alten Rom wie später in den Adelshäusern Venedigs.

Une collection inspirée du terrazzo à la vénitienne. Apprécié depuis l'Antiquité en Grèce, le terrazzo a été largement diffusé en Italie par les anciens Romains d'abord et par la noblesse vénitienne ensuite.

4

Colori
Colours
Farben
Couleurs

Rainbow

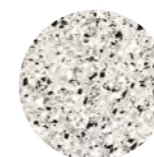

Cloud

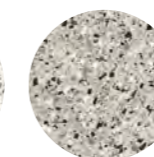

Fog

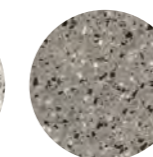

Storm

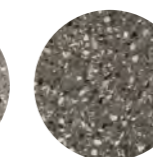

3

Formati
Sizes
Formate
Formats

60×120
24"×48"



60×60
24"×24"



30×60
12"×24"



1

Superfici
Surfaces
Oberflächen
Surfaces

Naturale

i

Effetto Contemporaneo
Contemporary effect
Moderne Wirkung
Effet Contemporain

Rivestimento
Wall Tiles
Wandfliesen
Revêtement

Pavimento
Floor Tiles
Bodenfliesen
Sol

Gres fine porcellanato ad impasto colorato
Coloured-body fine porcelain stoneware
Feinsteinzeug aus farbiger Masse
Grès cérame fin à pâte colorée

Tecnologia digitale
Digital technology
Digital Technologie
Technologie numérique

Rainbow



60x120
02657B | Venetian Marble Rainbow Nat/Ret

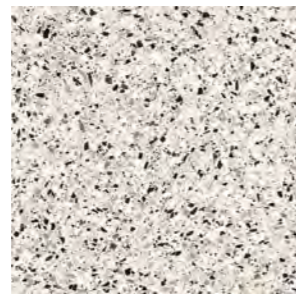

60x60
02688A | Venetian Marble Rainbow Nat/Ret

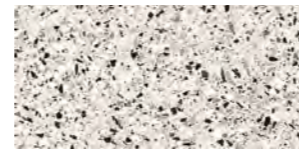

30x60
03063A | Venetian Marble Rainbow Nat/Ret

Cloud



60x120
02692B | Venetian Marble Cloud Nat/Ret

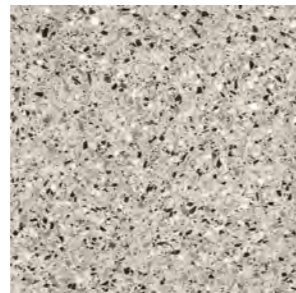

60x60
02689A | Venetian Marble Cloud Nat/Ret

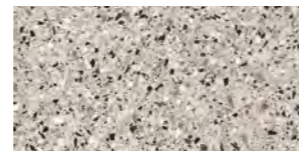

30x60
03066A | Venetian Marble Cloud Nat/Ret

Fog



60x120
02693B | Venetian Marble Fog Nat/Ret



60x60
02690A | Venetian Marble Fog Nat/Ret



30x60
03067A | Venetian Marble Fog Nat/Ret

Storm



60x120
02694A | Venetian Marble Storm Nat/Ret

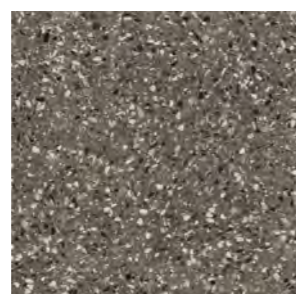

60x60
02691A | Venetian Marble Storm Nat/Ret



30x60
03068A | Venetian Marble Storm Nat/Ret

Imballi

Packing
Verpackung
Emballage

Formati Sizes		± MM	Pezzi Scatola Pieces/Box Stck/Karton Carreaux/Boite	Mq/Scatola Sqmt/Box Qm/Karton M2/Boite	Kg/Scatola Kgs/Box Kg/Karton Kg/Boite	Scatole/Paletta Boxes/Pallet Karton/Palette Boite/Palette	Mq/Paletta Sqmt/Pallet Qm/Pallet M2/Palette	Kg/Paletta Kgs/Pallet Kg/Pallet Kg/Palette	Formato Paletta Size Pallet Format Pallet Dim. Palette
60x120 (24"x48") Nat/Ret	P	8,5	2	1,44	28,00	36	51,84	1008	122x100x76
60x120 (24"x48") Nat/Ret (B)	P	8,5	2	1,44	28,00	44	63,36	1232	122x100x76
60x60 (24"x24") Nat/Ret	P	8,5	4	1,44	26,00	40	57,60	1040	122x82x75
30x60 (12"x24") Nat/Ret	P	8,5	7	1,26	22,50	48	60,48	1080	120x80x75
Pezzi Speciali / Special Pieces									
30x60 (12"x24") Step Nat/Ret	P	8,5	6	1,080	21,50	36	-	-	-
8x60 (3 1/2"x24") Battiscopa Nat/Ret	P	8,5	10	0,480	11,00	72	-	-	-

Riepilogo Gamma

Collection
Serie
Gamme

Formati Sizes		60x120 24"x48"	60x60 24"x24"	30x60 12"x24"		Pezzi Speciali Special Pieces	
						Step 30x60 - 12"x24"	Battiscopa 8x60 - 3 1/2"x24"
		± 8,5	± 8,5	± 8,5		± 8,5	± 8,5
Rainbow	Nat/Ret	02657B	02688A	03063A	V3	02812	02695
Cloud	Nat/Ret	02692B	02689A	03066A	V3	02813	02696
Fog	Nat/Ret	02693B	02690A	03067A	V3	02814	02697
Storm	Nat/Ret	02694A	02691A	03068A	V3	02815	02698

CEMENT EFFECT

Effetto Cemento / Beton Optik / Effet Béton

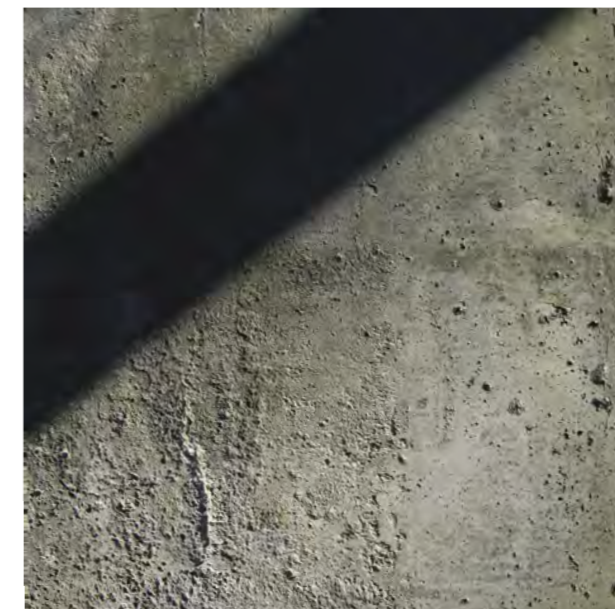

226 Cement Vibes PREMIUM /

252 Glitch ESSENZA /

272 Suprema EMPORIO /

276 Concrete EMPORIO /

Cement Vibes

Ispirata al cemento e alle sue differenti tonalità cromatiche, la collezione Cement Vibes reinterpreta una materia che esiste da sempre. Le due declinazioni Solid e Resin vengono mostrate con tutti i loro dettagli e caratteristiche: l'anima più strutturale, solida, vibrante e l'anima più fluida, più minimal, contemporanea del cemento.

Inspired by concrete and its different chromatic shades, the Cement Vibes collection reinterprets a material that has always existed. The two variations, Solid and Resin, are shown with all their details and characteristics: the more structural, vibrant essence, and the more fluid, contemporary aspect of concrete.

Inspiriert vom Beton und seinen verschiedenen Farbtönen, interpretiert die Kollektion Cement Vibes ein Material, das schon immer existiert, neu. Die beiden Ausführungen Solid und Resin werden mit all ihren Details und Eigenschaften gezeigt: die strukturellere, festere, lebendigere Seele und die flüssigere, minimalistischere, zeitgenössische Seele des Betons.

Inspirée par le béton et ses différentes nuances chromatiques, la collection Cement Vibes réinterprète une matière qui existe depuis toujours. Les deux déclinaisons Solid et Resin sont montrées avec tous leurs détails et caractéristiques: l'âme plus structurelle, solide et vibrante, et l'âme plus fluide, plus minimaliste et contemporaine du béton.

8

Colori
Colours
Farben
Couleurs

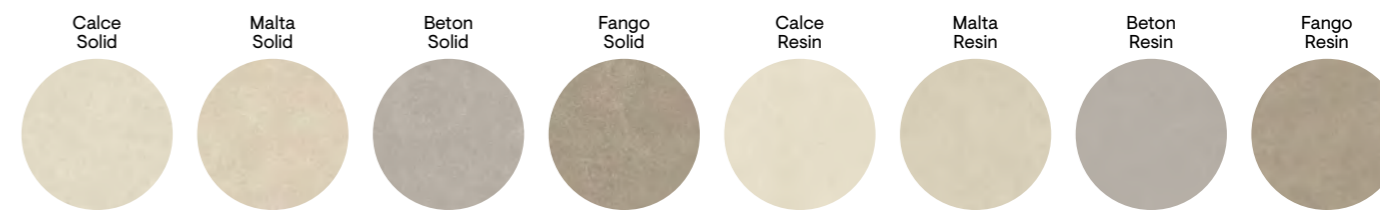

5

Formati
Sizes
Formate
Formats

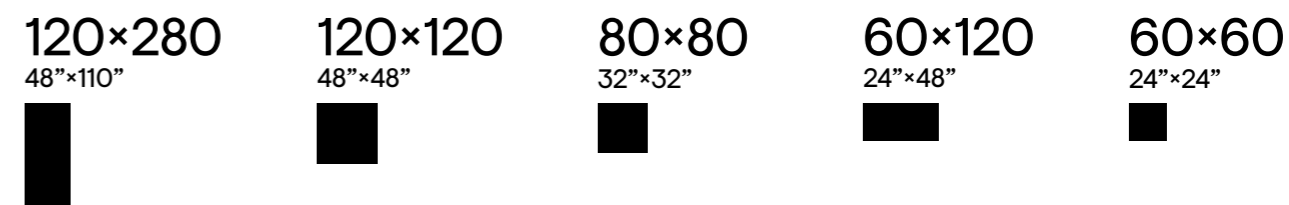

2

Superfici
Surfaces
Oberflächen
Surfaces

Naturale Antislip

1

Strutture 3D
3D structures
Strukturen
Décorations en relief



i

Effetto Cemento
Cement Look
Beton Optik
Effet Béton

Rivestimento
Wall Tiles
Wandfliesen
Revêtement

Pavimento
Floor Tiles
Bodenfliesen
Sol

Gres fine porcellanato ad impasto colorato
Coloured-body fine porcelain stoneware
Feinsteinzeug aus farbiger Masse
Grès cérame fin à pâte colorée

Tecnologia digitale
Digital technology
Digital technologie
Technologie numérique

Ripresa grafica tra le diverse lastre rettificate contenute entro le tolleranze previste dalla norma. Per un corretto allineamento si consiglia di utilizzare una fuga di 2 mm.
Graphic representation between the rectified tiles is contained within the tolerances provided by the standard. For a correct alignment it is recommended to use a 2 mm joint.
Grafische Darstellung zwischen den verschiedenen rektifizierten Platten innerhalb der in der Norm vorgesehenen Toleranzen. Für eine korrekte Anpassung wird eine Fuge von 2mm empfohlen.
Reproduction graphique entre les différents carreaux rectifiés dans les limites des tolérances prévues par la norme. Pour un alignement correct, il est recommandé d'utiliser joints de 2 mm.



Cement Vibes

Cement Effect
PREMIUM

Calce Solid



120x120
05959 | Calce Solid Nat/Ret
05967 | Calce Solid Antislip/Ret

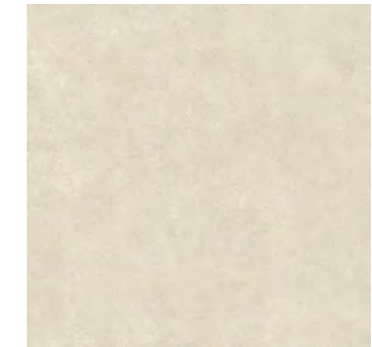

80x80
06156 | Calce Solid Nat/Ret

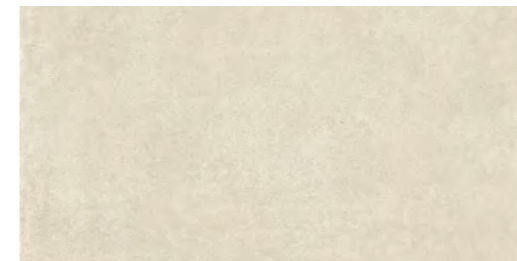

60x120
05951 | Calce Solid Nat/Ret

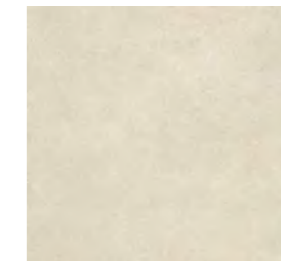

60x60
05942 | Calce Solid Nat/Ret
06152 | Calce Solid Antislip/Ret

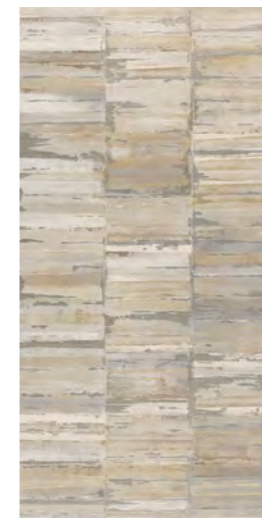

60x120
06041A | Graffiti Vibes Light Nat/Ret ± 6mm



60x120
06042A | Graffiti Vibes Dark Nat/Ret ± 6mm

THIN
60x120 6 mm



60x120
05990 | Handmade Vibes Calce Nat/Ret



Cement Vibes

Malta Solid



120x120
05960 | Malta Solid Nat/Ret
05968 | Malta Solid Antislip/Ret

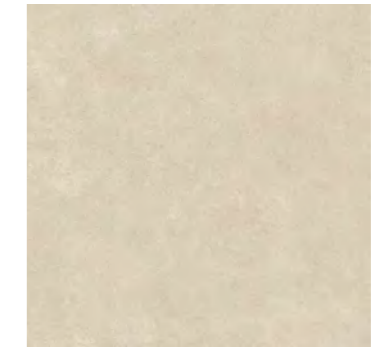

80x80
06157 | Malta Solid Nat/Ret

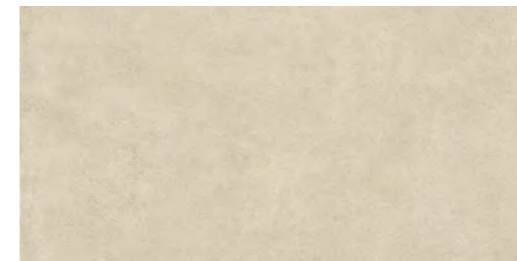

60x120
05952 | Malta Solid Nat/Ret

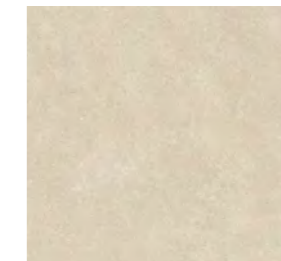

60x60
05943 | Malta Solid Nat/Ret
06153 | Malta Solid Antislip/Ret

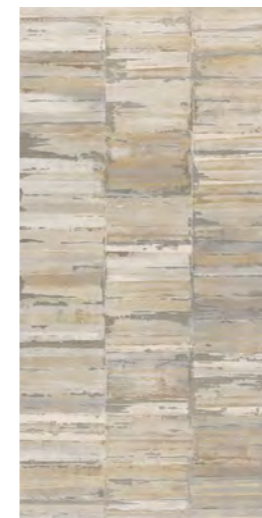

60x120
06041A | Graffiti Vibes Light Nat/Ret ± 6mm



60x120
06042A | Graffiti Vibes Dark Nat/Ret ± 6mm

THIN
 60x120 6 mm



60x120 - 24"x48"
05991 | Handmade Vibes Malta Nat/Ret

Cement Vibes

Beton Solid



120x120
05961 | Beton Solid Nat/Ret
05969 | Beton Solid Antislip/Ret

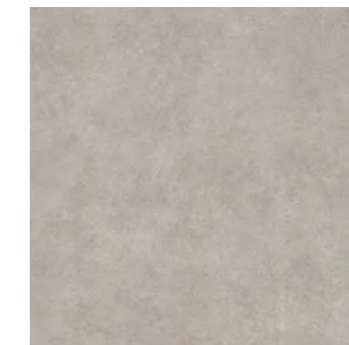

80x80
06158 | Beton Solid Nat/Ret

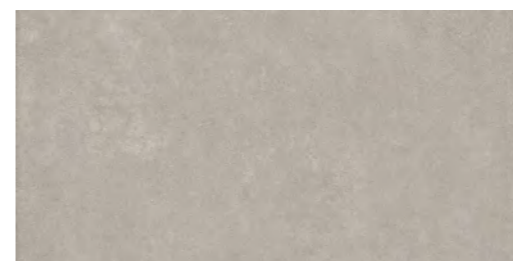

60x120
05953 | Beton Solid Nat/Ret

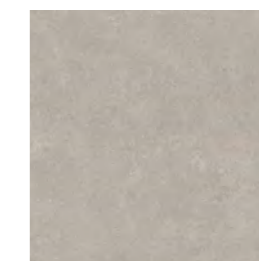

60x60
05944 | Beton Solid Nat/Ret
06154 | Beton Solid Antislip/Ret



60x120
06041A | Graffiti Vibes Light Nat/Ret ± 6mm



60x120
06042A | Graffiti Vibes Dark Nat/Ret ± 6mm

THIN
60x120 6 mm



60x120
05992 | Handmade Vibes Beton Nat/Ret

Cement Vibes

Fango Solid

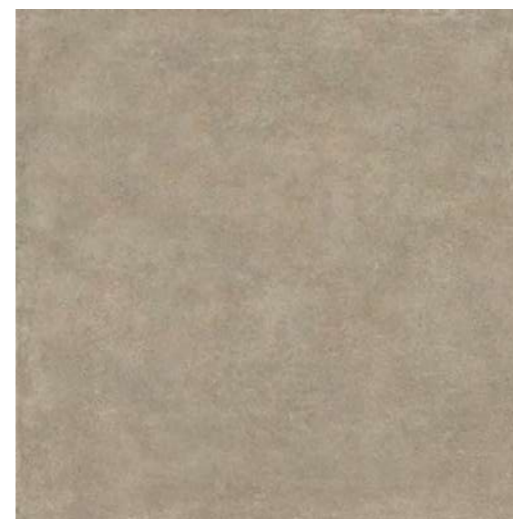

120x120
05962 | Fango Solid Nat/Ret
05970 | Fango Solid Antislip/Ret

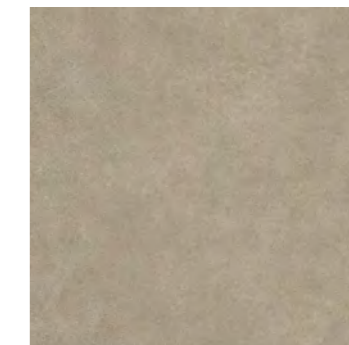

80x80
06159 | Fango Solid Nat/Ret



60x120
05954 | Fango Solid Nat/Ret

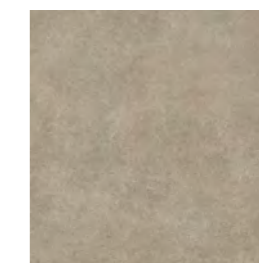

60x60
05945 | Fango Solid Nat/Ret
06155 | Fango Solid Antislip/Ret

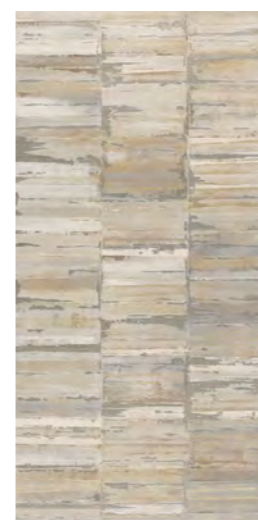

60x120
06041A | Graffiti Vibes Light Nat/Ret ± 6mm



60x120
06042A | Graffiti Vibes Dark Nat/Ret ± 6mm

THIN
60x120 6 mm



60x12
05993 | Handmade Vibes Fango Nat/Ret



Cement Vibes

Calce Resin

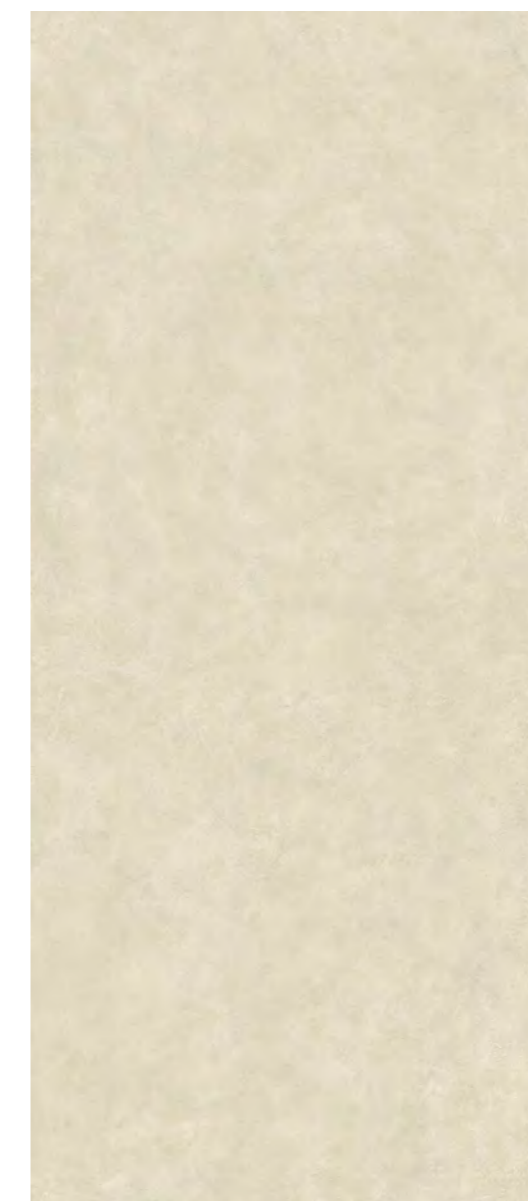

120x280
05971 | Calce Resin Nat/Ret

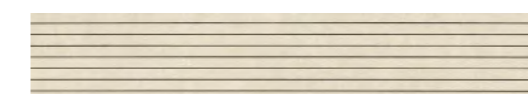

20x120
06043 | Calce Resin Cannelé Nat/Ret ± 6mm



30x30
06047 | Micromosaico Calce Resin Nat/Ret

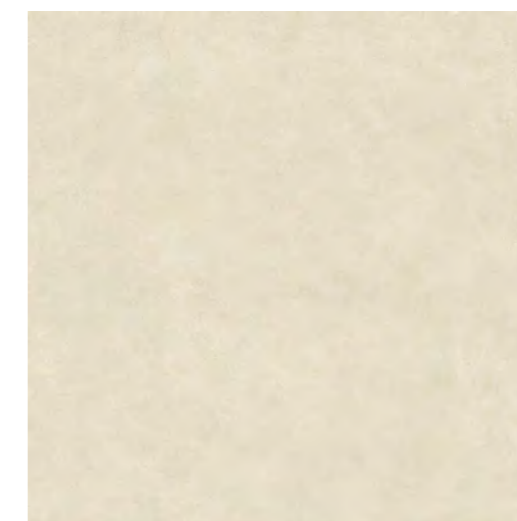

120x120
05963 | Calce Resin Nat/Ret

THIN
60x120 6 mm

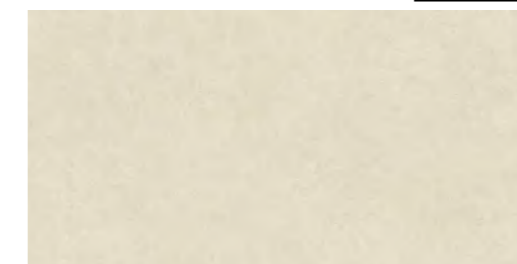

60x120
05955 | Calce Resin Nat/Ret
06037 | Calce Resin Nat/Ret ± 6mm

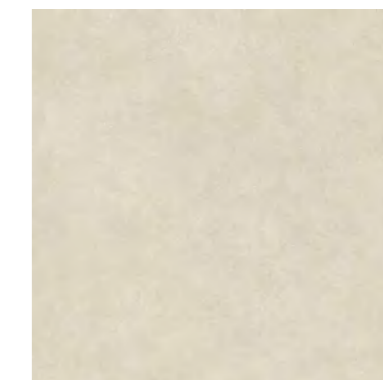

80x80
06160 | Calce Resin Nat/Ret

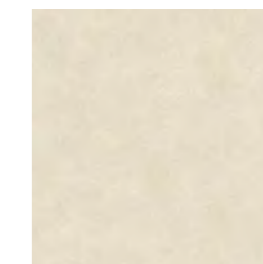

60x60
05947 | Calce Resin Nat/Ret

THIN
60x120 6 mm



60x120
05990 | Handmade Vibes Calce Nat/Ret

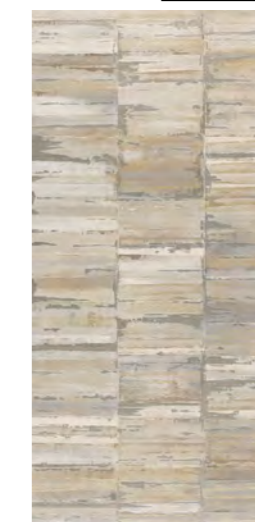

60x120
06041A | Graffiti Vibes Light Nat/Ret ± 6mm

Cement Vibes

Malta Resin

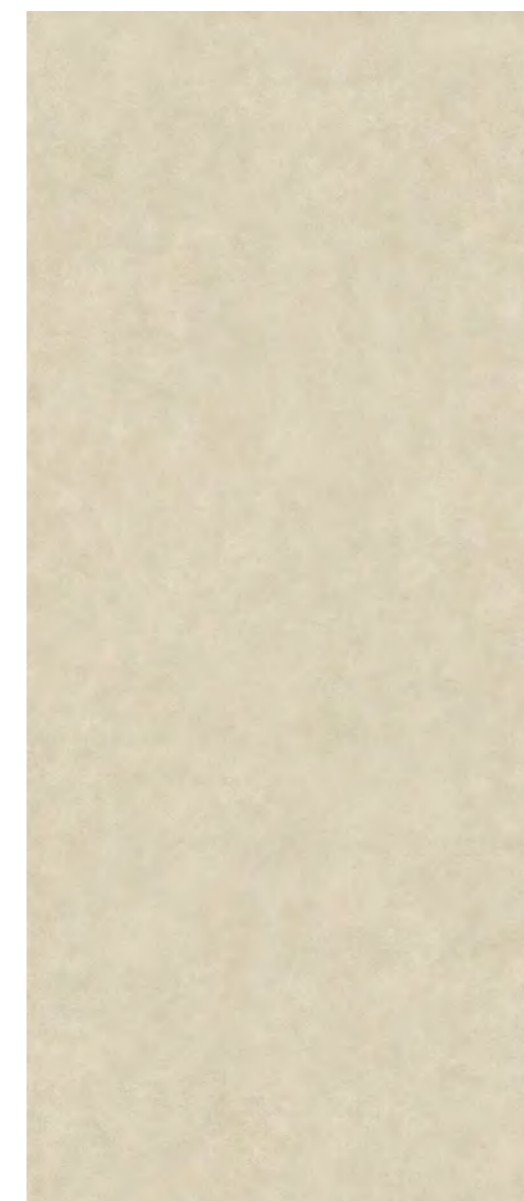

120x280
05972 | Malta Resin Nat/Ret

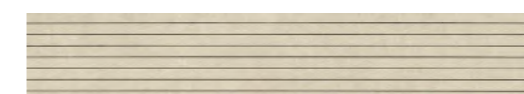

20x120
06044 | Malta Resin Cannelé Nat/Ret ± 6mm



30x30
06048 | Micromosaico Malta Resin Nat/Ret

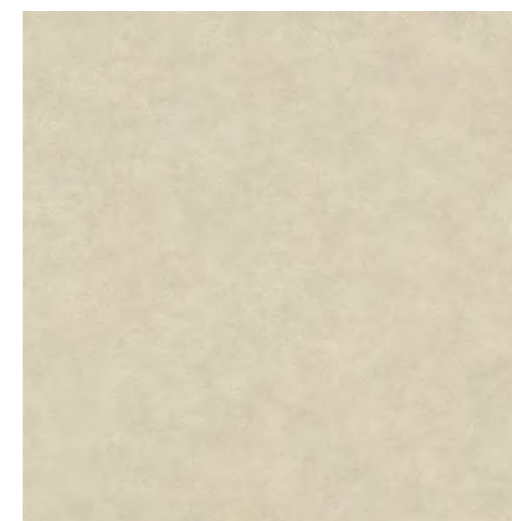

120x120
05964 | Malta Resin Nat/Ret

THIN
60x120 6 mm

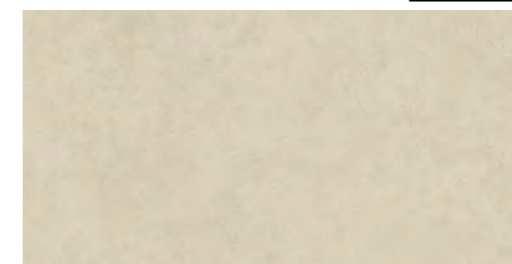

60x120
05956 | Malta Resin Nat/Ret
06038 | Malta Resin Nat/Ret ± 6mm

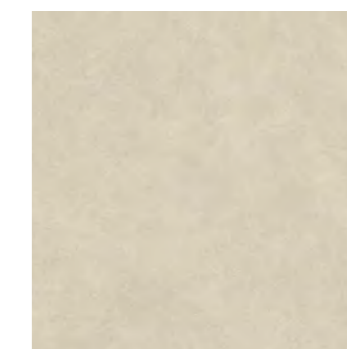

80x80
06161 | Malta Resin Nat/Ret

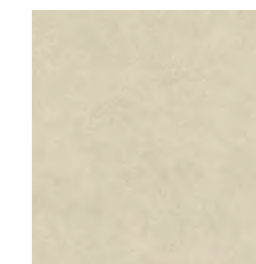

60x60
05948 | Malta Resin Nat/Ret

THIN
60x120 6 mm



60x120
05991 | Handmade Vibes Malta Nat/Ret

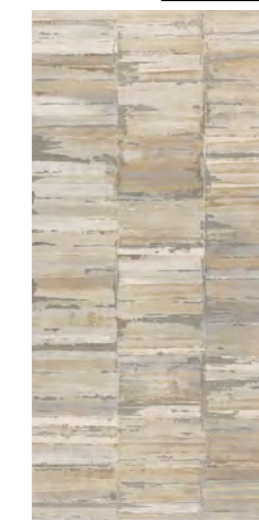

60x120
06041A | Graffiti Vibes Light Nat/Ret ± 6mm

Pezzi speciali
Special pieces

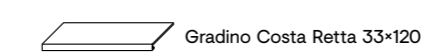
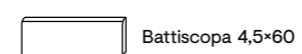



Cement Vibes

Cement Effect
PREMIUM

Beton Resin

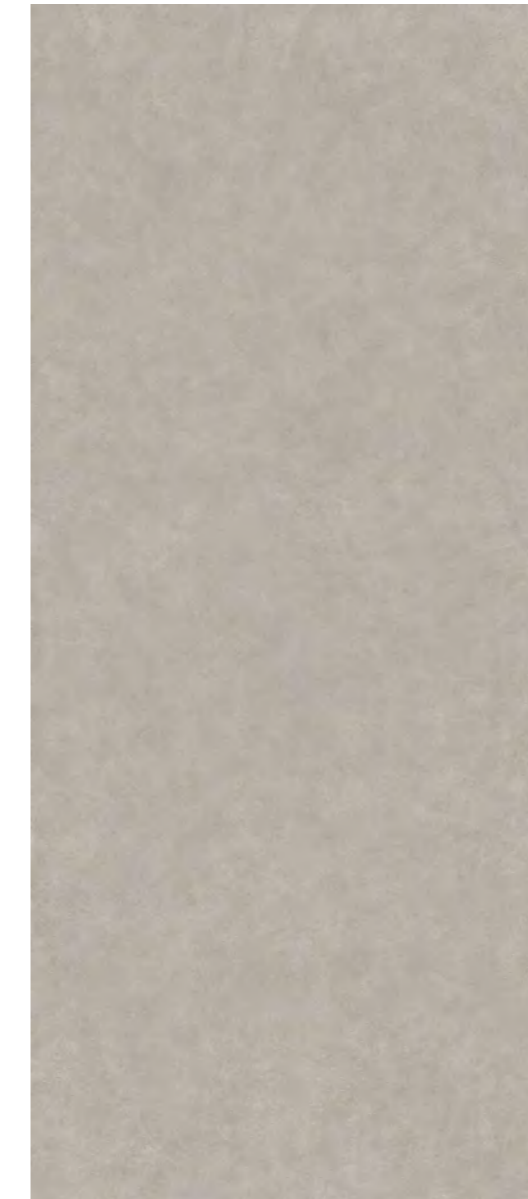

120x280
05973 | Beton Resin Nat/Ret



20x120
06045 | Beton Resin Cannelé Nat/Ret ± 6mm



30x30
06049 | Micromosaico Beton Resin Nat/Ret

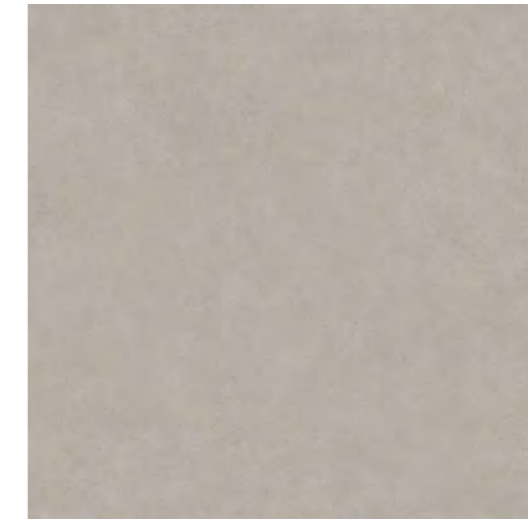

120x120
05965 | Beton Resin Nat/Ret

THIN
60x120 6 mm

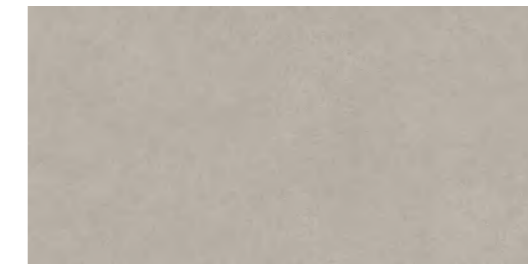

60x120
05957 | Beton Resin Nat/Ret
06039 | Beton Resin Nat/Ret ± 6mm

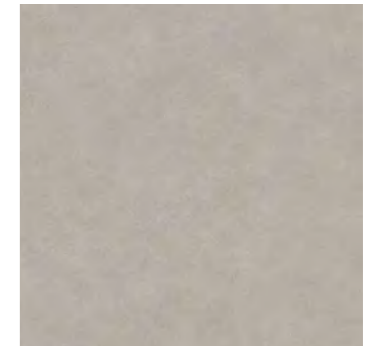

80x80
06162 | Beton Resin Nat/Ret



60x60
05949 | Beton Resin Nat/Ret

THIN
60x120 6 mm



60x120
05992 | Handmade Vibes Beton Nat/Ret

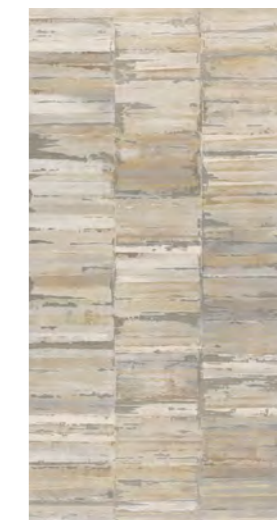

60x120
06041A | Graffiti Vibes Light Nat/Ret ± 6mm

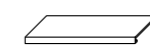
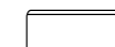



Fango Resin



120×280
05974 | Fango Resin Nat/Ret



20×120
06046 | Fango Resin Cannelé Nat/Ret ± 6mm



30×30
06050 | Micromosaico Fango Resin Nat/Ret

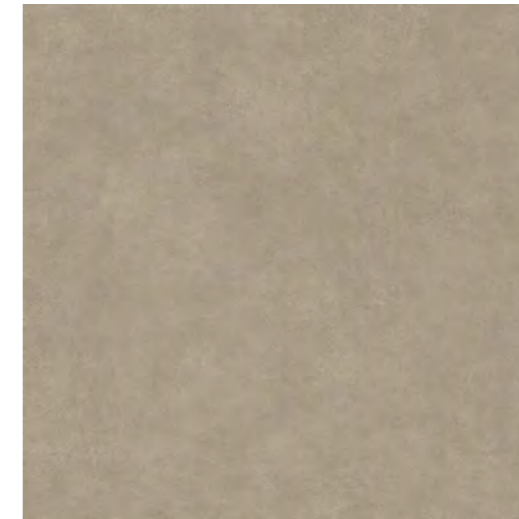

120×120
05966 | Fango Resin Nat/Ret



80×80
06163 | Fango Resin Nat/Ret

THIN
60×120 6 mm

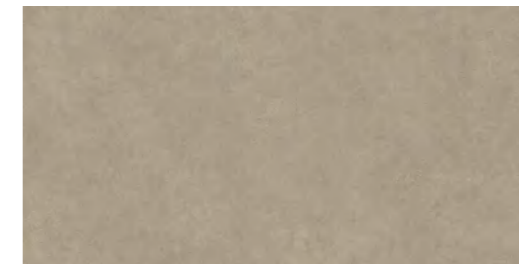

60×120
05958 | Fango Resin Nat/Ret
06040 | Fango Resin Nat/Ret ± 6mm

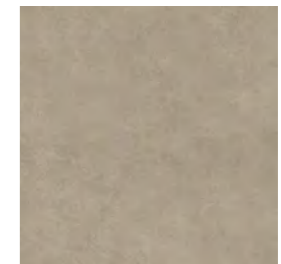

60×60
05950 | Fango Resin Nat/Ret

THIN
60×120 6 mm



60×120
05993 | Handmade Vibes Fango Nat/Ret



60×120
06042A | Graffiti Vibes Dark Nat/Ret ± 6mm

Fairy Light



120x280
06051 | Fairy Vibes Light A Nat/Ret



120x280
06052 | Fairy Vibes Light B Nat/Ret

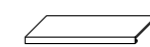
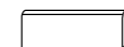

Cement Vibes

Fairy Dark



120x280
06053 | Fairy Vibes Dark A Nat/Ret



120x280
06054 | Fairy Vibes Dark B Nat/Ret



Cement Vibes

Cement Effect
PREMIUM

Graffiti

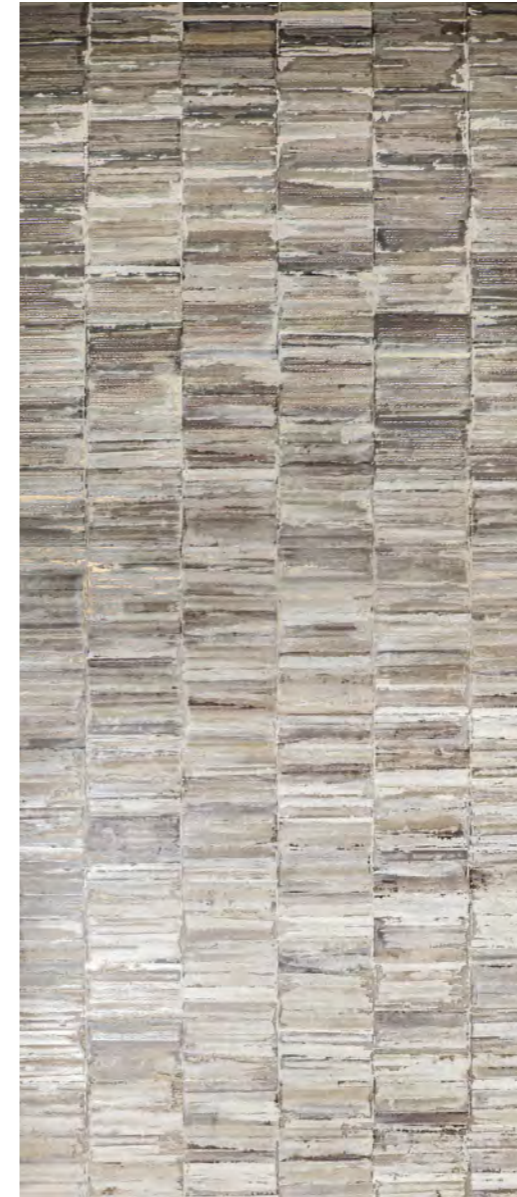

120x280
06055 | Graffiti Vibes Light Nat/Ret

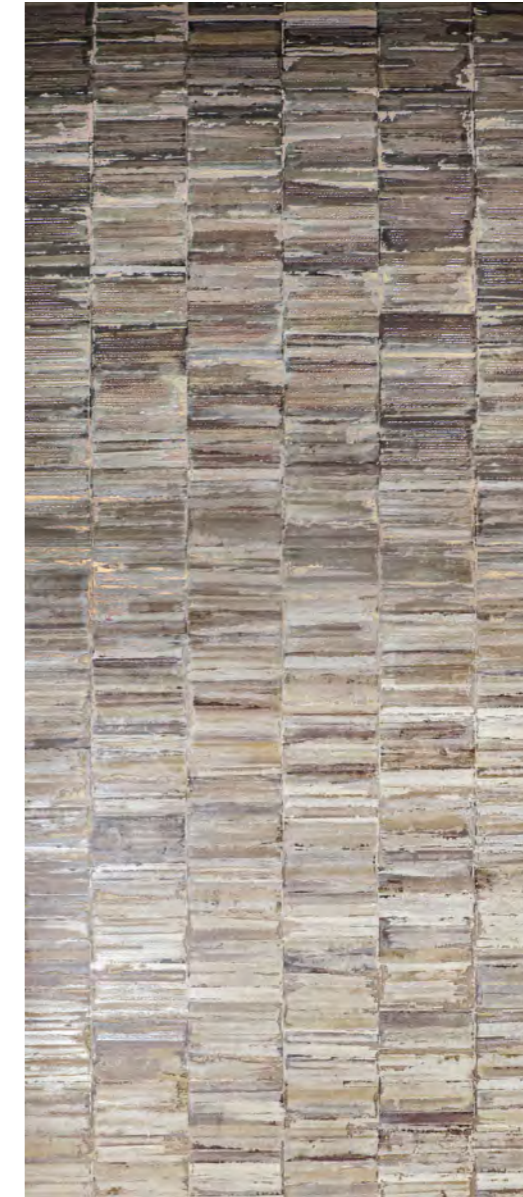

120x280
06056 | Graffiti Vibes Dark Nat/Ret

Imballi

Packing
Verpackung
Emballage

Formati Sizes	± MM	Pezzi Scatola Pieces/Box Stck/Karton Carreaux/Boîte	Mq/Scatola Sqmt/Box Qm/Karton M2/Boîte	Kg/Scatola Kgs/Box Kg/Karton Kg/Boîte	Scatole/Paletta Boxes/Pallet Karton/Palette Boîte/Palette	Mq/Paletta Sqmt/Pallet Qm/Pallet M2/Palette	Kg/Paletta Kgs/Pallet Kg/Pallet Kg/Palette	Formato Paletta Size Pallet Format Pallet Dim. Palette	
120x280 (48"x110") Resin Nat/Ret	P	6,0	1	3,36	46,50	20	67,20	930	143x294x35
120x120 (48"x48") Nat/Ret - Antislip/Ret	P	8,5	2	2,88	55,00	24	69,12	1320	135x122x68
80x80 (32"x32") Nat/Ret	P	8,5	2	1,28	24,50	54	69,12	1323	124x80x96
60x120 (24"x48") Nat/Ret	P	8,5	2	1,44	28,00	44	63,36	1232	122x100x75
60x120 (24"x48") Nat/Ret	P	6	3	2,16	29,50	36	77,76	1062	122x95x75
60x60 (24"x24") Nat/Ret - Antislip/Ret	P	8,5	4	1,44	26,00	40	57,6	1040	120x82x75
60x120 (24"x48") Handmade Nat/Ret	P	8,5	2	1,44	28,00	44	63,36	1232	122x100x75
60x120 (24"x48") Graffiti Light Nat/Ret	P	6	3	2,16	29,50	36	77,76	1062	122x95x75
60x120 (24"x48") Graffiti Dark Nat/Ret	P	6	3	2,16	29,50	36	77,76	1062	122x95x75
20x120 (8"x48") Canneté Resin Nat/Ret	P	6	6	1,44	19,00	36	-	-	-
30x30 (12"x12") Micromosaico Resin Nat/Ret	P	8,5	7	0,63	12,00	60	-	-	-
Pezzi Speciali / Special Pieces									
33x120 (13"x48") Gradino Costa Retta Nat/Ret	P	8,5	2	0,79	15,60	20	-	-	-
4,5x60 (1 1/2"x24") Battiscopa Nat/Ret - Lap/Ret	P	8,5	14	0,38	8,00	80	-	-	-

Riepilogo Gamma

[PDF Merchandising](#)

Collection Serie Gamme	Formati Sizes	UPEC						Pezzi Speciali Special Pieces									
		120x280 48"x110"	120x120 48"x48"	80x80 32"x32"	60x120 24"x48"	60x120 24"x48"	60x60 24"x24"	EN 16165C	EN 16165A	DCOF	Handmade 60x120 24"x48"	Graffiti Light 60x120 24"x48"	Graffiti Dark 60x120 24"x48"	Canneté Resin 20x120 8"x48"	Micromos. Resin 30x30 12"x12"	Gradino Costa Retta 33x120 13"x48"	Battiscopa 4,5x60 1 1/2"x24"
Calce Solid	Nat/Ret		05959	06156		05951	05942	R10	A+B		05990	06041A	06042A			06002	05994
	Antislip/ Ret		05967				06152	R11	A+B+C	>0.42							
Malta Solid	Nat/Ret		05960	06157		05952	05943	R10	A+B		05991	06041A	06042A			06003	05995
	Antislip/ Ret		05968				06153	R11	A+B+C	>0.42							
Beton Solid	Nat/Ret		05961	06158		05953	05944	R10	A+B		05992	06041A	06042A			06004	05996
	Antislip/ Ret		05969				06154	R11	A+B+C	>0.42							
Fango Solid	Nat/Ret		05962	06159		05954	05945	R10	A+B		05993	06041A	06042A			06005	05997
	Antislip/ Ret		05970				06155	R11	A+B+C	>0.42							
Calce Resin	Nat/Ret	05971	05963	06160	06037	05955	05947	R10	A+B		05990	06041A	06042A	06043	06047	06006	05998
	Antislip/ Ret							R11	A+B+C	>0.42							
Malta Resin	Nat/Ret	05972	05964	06161	06038	05956	05948	R10	A+B		05991	06041A	06042A	06044	06048	06007	05999
	Antislip/ Ret							R11	A+B+C	>0.42							
Beton Resin	Nat/Ret	05973	05965	06162	06039	05957	05949	R10	A+B		05992	06041A	06042A	06045	06049	06008	06000
	Antislip/ Ret							R11	A+B+C	>0.42							
Fango Resin	Nat/Ret	05974	05966	06163	06040	05958	05950	R10	A+B		05993	06041A	06042A	06046	06050	06009	06001
	Antislip/ Ret							R11	A+B+C	>0.42							
Fairy Light	Nat/Ret	06051 (A)															
	Antislip/ Ret	06052 (B)															
Fairy Dark	Nat/Ret	06053 (A)															
	Antislip/ Ret	06054 (B)															
Graffiti	Nat/Ret	06055 (Light)															
	Antislip/ Ret	06056 (Dark)															

Glitch

Designed by Benoy

Glitch è una gamma di piastrelle in grès porcellanato sviluppata da Piemme in collaborazione con uno dei maggiori studi di design a livello internazionale: Benoy. Glitch si propone di valorizzare le caratteristiche disomogenee presenti nel calcestruzzo e tutte quelle piccole imperfezioni che caratterizzano questa superficie, come crepe, patine, graffi ed i segni lasciati nel tempo dagli agenti atmosferici.

Glitch is a range of porcelain stoneware tiles developed by Piemme in partnership with one of the biggest international design studios: Benoy. Glitch brings out and highlights the heterogeneous nature of concrete, and all those little imperfections characteristic of this surface, such as cracks, patinas, scratches and weathering.

Glitch ist eine Fliesenserie aus Feinsteinzeug, die Piemme in Kooperation mit dem namhaften Designbüro Benoy entwickelte. Glitch bringt die Betonoberfläche in ihrer Unvollkommenheit, samt all ihren kleinen Makeln wie Risse, Ablagerungen, Kratzer und Verwitterungserscheinungen.

Glitch est une collection de carreaux en grès cérame imaginée par Piemme en collaboration avec l'un des plus prestigieux bureaux de design sur la scène internationale: Benoy. Glitch veut mettre en valeur les hétérogénéités du béton, ainsi que toutes les petites imperfections distinctives de cette surface, comme les craquements, les patines, les rayures et les signes que les agents atmosphériques laissent au fil du temps.

8

Colori
Colours
Farben
Couleurs

Salt



Sand



Gravel



Clay



Ash



Flint



Graphite

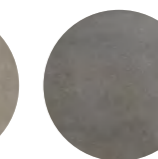

Carbon

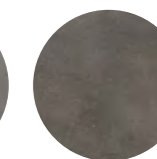

5

Formati
Sizes
Formate
Formats

120×120
48"×48"



60×120
24"×48"



80×80
31½"×31½"



60×60
24"×24"



30×60
12"×24"



3

Superfici
Surfaces
Oberflächen
Surfaces

Naturale

Antislip

Grip

1

Strutture 3D
3D structures
Strukturen
Decorations and relief

Fault

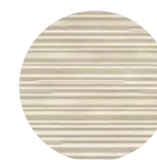

i

Effetto Cemento
Cement Look
Beton Optik
Effet Béton

Rivestimento
Wall Tiles
Wandfliesen
Revêtement

Pavimento
Floor Tiles
Bodenfliesen
Sol

Gres fine porcellanato ad impasto colorato
Coloured-body fine porcelain stoneware
Feinsteinzeug aus farbiger Masse
Grès cérame fin à pâte colorée

Tecnologia digitale
Digital technology
Digital technologie
Technologie numérique

Ripresa grafica tra le diverse lastre rettificata contenuta entro le tolleranze previste dalla norma. Per un corretto allineamento si consiglia di utilizzare una fuga di 2 mm.
Graphic representation between the rectified tiles is contained within the tolerances provided by the standard. For a correct alignment it is recommended to use a 2 mm joint.
Grafische Darstellung zwischen den verschiedenen rektifizierten Platten innerhalb der in der Norm vorgesehenen Toleranzen. Für eine korrekte Anpassung wird eine Fuge von 2mm empfohlen.
Reproduction graphique entre les différents carreaux rectifiés dans les limites des tolérances prévues par la norme. Pour un alignement correct, il est recommandé d'utiliser joints de 2 mm.

WATCH THE VIDEO



Glitch

Salt

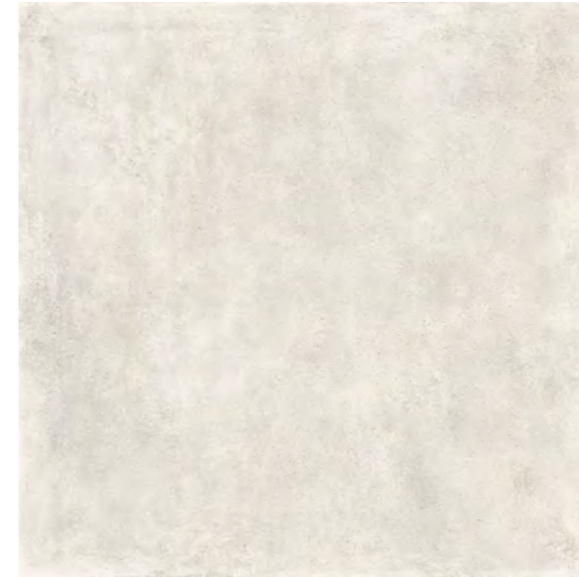

120x120
03292A | Glitch Salt Nat/Ret

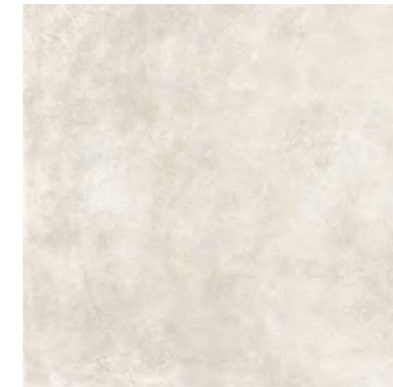

80x80
05288 | Glitch Salt Nat/Ret



60x60
03285A | Glitch Salt Nat/Ret
03465A | Glitch Salt Antislip/Ret

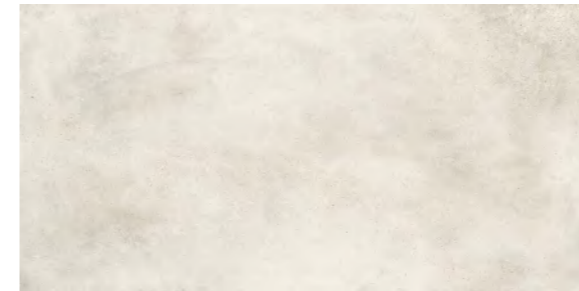

60x120
03267B | Glitch Salt Nat/Ret



60x120
03298B | Glitch Fault Salt Nat/Ret



30x60
03276A | Glitch Salt Nat/Ret



60x120
03304B | Glitch Mix Warm Nat/Ret

Glitch

Sand



120x120
05363 | Glitch Sand Nat/Ret

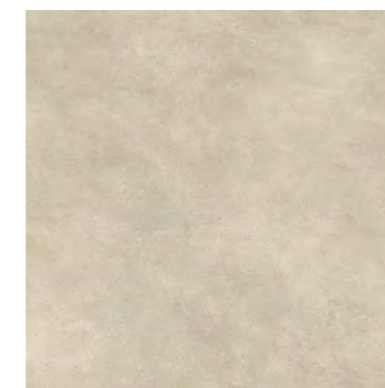

80x80
06259 | Glitch Sand Nat/Ret

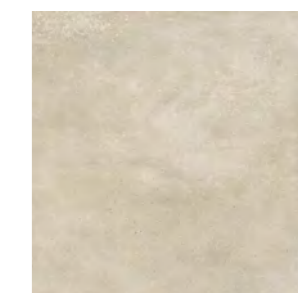

60x60
03891B | Glitch Sand Grip/Ret ± 20mm

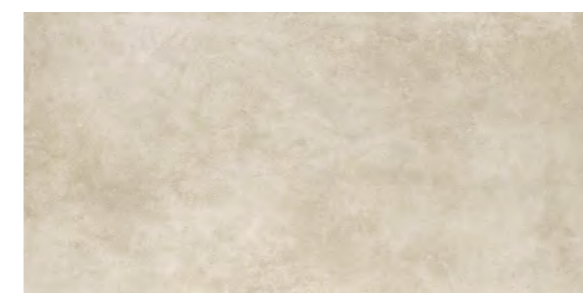

60x120
05579A | Glitch Sand Grip/Ret ± 20mm



60x120
03297B | Glitch Fault Sand Nat/Ret

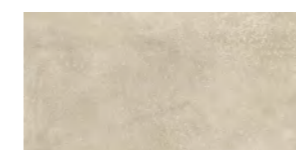

30x60
03275A | Glitch Sand Nat/Ret



60x120
03304B | Glitch Mix Warm Nat/Ret

Glitch

Gravel



120x120
03291A | Glitch Gravel Nat/Ret

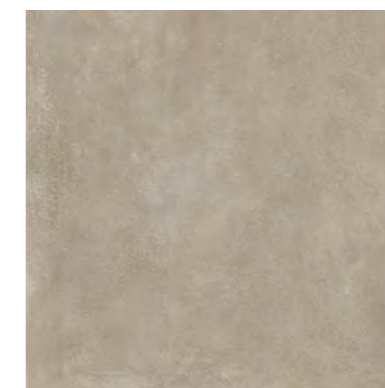

80x80
05287 | Glitch Gravel Nat/Ret

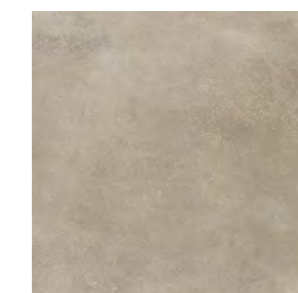

60x60
03283A | Glitch Gravel Nat/Ret
03464A | Glitch Gravel Antislip/Ret
03889B | Glitch Gravel Grip/Ret \pm 20mm

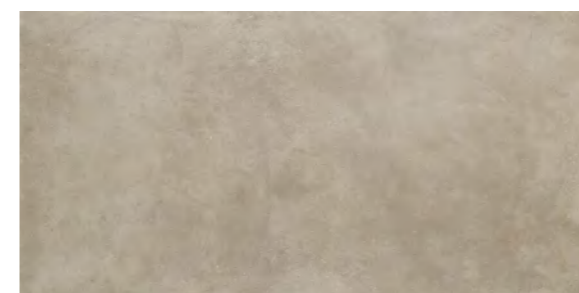

60x120
03265B | Glitch Gravel Nat/Ret
05580 | Glitch Gravel Grip/Ret \pm 20mm



60x120
03296B | Glitch Fault Gravel Nat/Ret



30x60
03274A | Glitch Gravel Nat/Ret



60x120
03304B | Glitch Mix Warm Nat/Ret



Glitch

Clay



60x120
03264B | Glitch Clay Nat/Ret

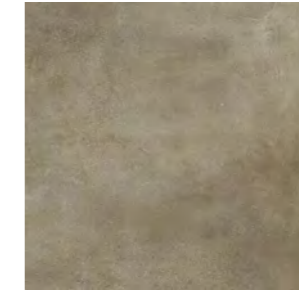

60x60
03282A | Glitch Clay Nat/Ret



30x60
03273A | Glitch Clay Nat/Ret



60x120
03295B | Glitch Fault Clay Nat/Ret



60x120
03304B | Glitch Mix Warm Nat/Ret

Glitch

Ash



120x120
03293A | Glitch Ash Nat/Ret

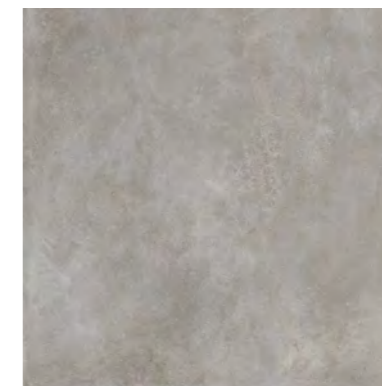

80x80
05289 | Glitch Ash Nat/Ret

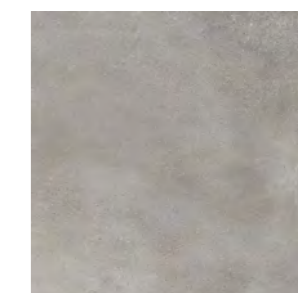

60x60
03286A | Glitch Ash Nat/Ret
03466A | Glitch Ash Antislip/Ret
03892B | Glitch Ash Grip/Ret \pm 20mm

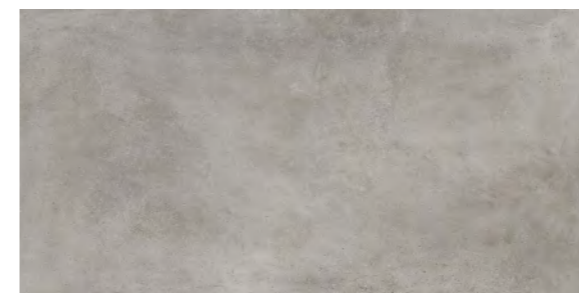

60x120
03268B | Glitch Ash Nat/Ret
05581 | Glitch Ash Grip/Ret \pm 20mm



60x120
03299B | Glitch Fault Ash Nat/Ret

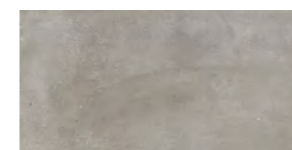

30x60
03277A | Glitch Ash Nat/Ret

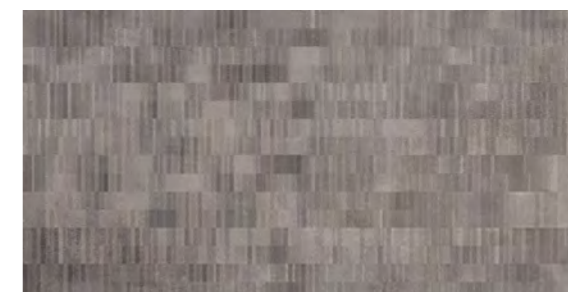

60x120
03305B | Glitch Mix Cold Nat/Ret



Glitch

Flint



60x120
03269A | Glitch Flint Nat/Ret

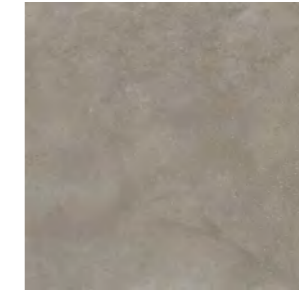

60x60
03287A | Glitch Flint Nat/Ret



30x60
03278A | Glitch Flint Nat/Ret



60x120
03301A | Glitch Fault Flint Nat/Ret



60x120
03305B | Glitch Mix Cold Nat/Ret

Glitch

Graphite



120x120
03294A | Glitch Graphite Nat/Ret

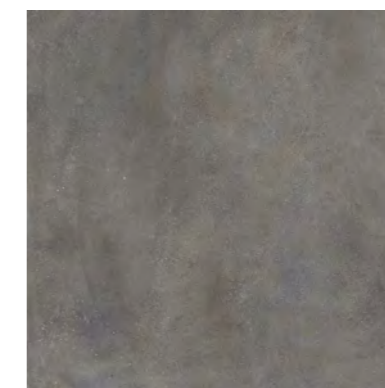

80x80
05291 | Glitch Graphite Nat/Ret

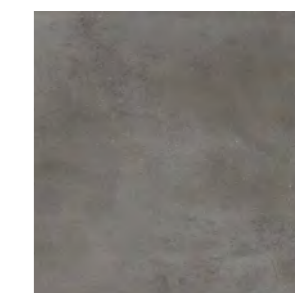

60x60
03288A | Glitch Graphite Nat/Ret
03467A | Glitch Graphite Antislip/Ret

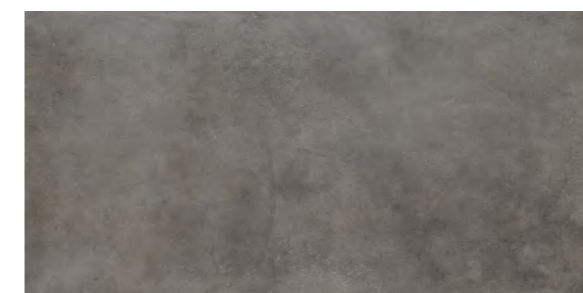

60x120
03271B | Glitch Graphite Nat/Ret



60x120
03302A | Glitch Fault Graphite Nat/Ret

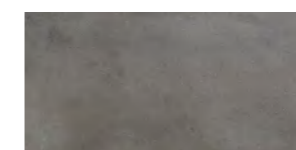

30x60
03279A | Glitch Graphite Nat/Ret



60x120
03305B | Glitch Mix Cold Nat/Ret

Carbon



60x120
03272B | Glitch Carbon Nat/Ret



60x60
03289A | Glitch Carbon Nat/Ret



30x60
03281A | Glitch Carbon Nat/Ret



60x120
03303A | Glitch Fault Carbon Nat/Ret



60x120
03305B | Glitch Mix Cold Nat/Ret

Imballi

Packing
Verpackung
Emballage

Formati Sizes		± MM	Pezzi Scatola Pieces/Box Stck/Karton Carreaux/Boîte	Mq/Scatola Sqmt/Box Qm/Karton M2/Boîte	Kg/Scatola Kgs/Box Kg/Karton Kg/Boîte	Scatole/Paletta Boxes/Pallet Karton/Palette Boîte/Palette	Mq/Paletta Sqmt/Pallet Qm/Pallet M2/Palette	Kg/Paletta Kgs/Pallet Kg/Pallet Kg/Palette	Formato Paletta Size Pallet Format Pallet Dim. Palette
120x120 (48"x48") Nat/Ret	P	9,5	2	2,88	58,00	22	63,36	1276	135x122x68
80x80 (31½"x31½") Nat/Ret	P	9,5	2	1,28	27,50	50	64,00	1375	122x80x96
60x120 (24"x48") Nat/Ret (A)	P	9,5	2	1,44	31,00	30	43,20	930	122x82x75
60x120 (24"x48") Nat/Ret - Fault - Mix (B)	P	9,5	2	1,44	31,00	36	51,84	1116	122x95x76
60x120 (24"x48") Grip/Ret	P	20	1	0,72	33,00	36	25,92	1188	122x96x75
60x120 (24"x48") Grip/Ret (A)	P	20	1	0,72	33,00	30	21,60	990	122x95x75
60x60 (24"x24") Nat/Ret	P	9,5	4	1,44	29,00	32	46,08	928	120x80x75
60x60 (24"x24") Antislip/Ret	P	9,5	4	1,44	29,00	32	46,08	928	120x80x75
60x60 (24"x24") Grip/Ret	P	20	2	0,72	32,40	32	23,04	1036,8	120x80x75
30x60 (12"x24") Nat/Ret	P	9,5	7	1,26	25,30	40	50,40	1012	120x80x75
60x120 (24"x48") Fault Nat/Ret	P	9,5	2	1,44	31,00	30	43,20	930	122x82x75
Pezzi Speciali / Special Pieces									
33x120 (13"x48") Gradino Costa Retta Nat/Ret	P	9,5	2	0,792	18,50	20	-	-	-
4,5x60 (1½"x24") Battiscopa Nat/Ret	P	9,5	14	0,378	8,00	80	-	-	-

Riepilogo Gamma

Collection
Serie
Gamme

Formati Sizes		120x120 48"x48"	80x80 31½"x31½"	60x120 24"x48"	60x120 24"x48"	60x60 24"x24"	60x60 24"x24"	30x60 12"x24"	EN 16165C	EN 16165A	DCOF	BS EN 16165: 2021-C	AS 4586 2013	
		± 9,5	± 9,5	± 9,5	± 20	± 9,5	± 20	± 9,5						
Warm Tones	Nat/Ret	03292A	05288	03267B		03285A		03276A	V2	R10	A+B		wet, dry >36	P3
	Antislip/Ret					03465A				R11	A+B+C	> 0,42	wet, dry >36	P4
Salt	Nat/Ret	05363	06259	03266B		03284A		03275A	V2	R10	A+B		wet, dry >36	P3
	Grip/Ret				05579A		03891B			R11	A+B+C	> 0,42		
Sand	Nat/Ret	03291A	05287	03265B		03283A		03274A	V2	R10	A+B		wet, dry >36	P3
	Antislip/Ret					03464A				R11	A+B+C	> 0,42	wet, dry >36	P4
	Grip/Ret				05580		03889B			R11	A+B+C	> 0,42		
Gravel	Nat/Ret			03264B		03282A		03273A	V2	R10	A+B		wet, dry >36	P3
	Antislip/Ret									R11	A+B+C	> 0,42	wet, dry >36	P4
Clay	Nat/Ret								V2	R10	A+B		wet, dry >36	P3
	Antislip/Ret									R11	A+B+C	> 0,42	wet, dry >36	P4
	Grip/Ret				05581		03892B			R11	A+B+C	> 0,42		
Cold Tones	Nat/Ret	03293A	05289	03268B		03286A		03277A	V2	R10	A+B		wet, dry >36	P3
	Antislip/Ret					03466A				R11	A+B+C	> 0,42	wet, dry >36	P4
Ash	Nat/Ret								V2	R10	A+B		wet, dry >36	P3
	Antislip/Ret									R11	A+B+C	> 0,42	wet, dry >36	P4
Flint	Nat/Ret			03269A		03287A		03278A	V2	R10	A+B		wet, dry >36	P3
	Antislip/Ret									R11	A+B+C	> 0,42	wet, dry >36	P4
Graphite	Nat/Ret	03294A	05291	03271B		03288A		03279A	V2	R10	A+B		wet, dry >36	P3
	Antislip/Ret					03467A				R11	A+B+C	> 0,42	wet, dry >36	P4
Carbon	Nat/Ret			03272B		03289A		03281A	V2	R10	A+B		wet, dry >36	P3
	Antislip/Ret									R11	A+B+C	> 0,42	wet, dry >36	P4

Riepilogo Gamma

Collection
Serie
Gamme

PDF Merchandising

				Pezzi Speciali Special Pieces	
Formati Sizes		Fault 60x120 24"x48"	Mix 60x120 24"x48"	Gradino Costa Retta 33x120 13"x48"	Battiscopa 4,5x60 1½"x24"
		± 9,5	± 9,5	± 9,5	± 9,5
Warm Tones	Nat/Ret	03298B	03304B	03321A	03313
	Antislip/Ret				
Salt	Nat/Ret	03297B	03304B	03320A	03312
	Antislip/Ret				
Sand	Nat/Ret	03296B	03304B	03731A	03311
	Antislip/Ret				
Gravel	Nat/Ret	03295B	03304B	03318A	03310
	Antislip/Ret				
Clay	Nat/Ret	03299B	03305B	03732A	03314
	Antislip/Ret				
Cold Tones	Nat/Ret	03301A	03305B	03323A	03315
	Antislip/Ret				
Ash	Nat/Ret	03302A	03305B	03324A	03316
	Antislip/Ret				
Flint	Nat/Ret	03303A	03305B	03325A	03317
	Antislip/Ret				

Suprema

La ricerca stilistica per la collezione Suprema trae ispirazione dall'estetica del cemento rasato impiegato nel design d'interni di impronta moderna. Suprema, con le sue molteplici sfumature e le leggere imperfezioni che la rendono unica, è la superficie in gres porcellanato ideale per garantire comfort e resistenza in ambienti residenziali e commerciali dallo stile sobrio ed al passo con i tempi.

The Suprema collection's distinctive style is inspired by the smoothed concrete used in modern interior design. With its unique multiple variations in shade and subtle flaws, Suprema is the ideal porcelain stoneware surface for providing convenient, hard-wearing coverings in residential and commercial locations with tasteful yet contemporary design schemes.

Der Stil der Kollektion Suprema orientiert sich an der Optik von geglättetem Beton, der das moderne Interior-Design prägt. Das Feinsteinzeug Suprema ist aufgrund seiner mannigfaltigen Nuancen und feinen Unregelmäßigkeiten die ideale Lösung für komfortable, strapazierfähige Beläge im privaten und gewerblichen Bereich, die auf schlichte, zeitgemäße Optik setzen.

Pour la collection Suprema, la recherche stylistique puise son inspiration dans l'esthétique du béton lissé appliqué dans les intérieurs modernes. Avec ses innombrables dégradés et ses légères imperfections qui en font une chose unique, Suprema est la surface en grès cérame idéale pour garantir confort et résistance dans les cadres résidentiels et commerciaux affichant un style sobre et actuel.

4

Colori
Colours
Farben
Couleurs

Gesso



Sabbia



Terra

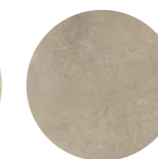

Cenere



3

Formati
Sizes
Formate
Formats

80×80
31½"×31½"



60×60
24"×24"



30×60
12"×24"



2

Superfici
Surfaces
Oberflächen
Surfaces

Naturale

Antislip

i

Effetto Cemento
Cement look
Betonoptik
Effet Béton

Rivestimento
Wall Tiles
Wandfliesen
Revêtement

Pavimento
Floor Tiles
Bodenfliesen
Sol

Gres fine porcellanato ad impasto colorato
Coloured-body fine porcelain stoneware
Feinsteinzeug aus farbiger Masse
Grès cérame fin à pâte colorée

Tecnologia digitale
Digital technology
Digital Technologie
Technologie numérique

Gesso

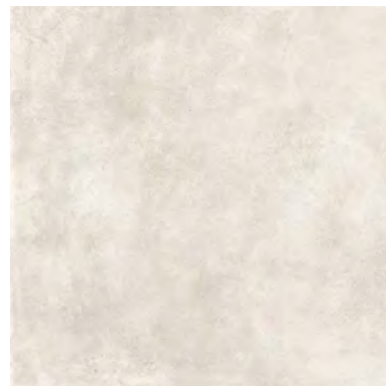

80x80
05252 | Suprema Gesso Nat/Ret

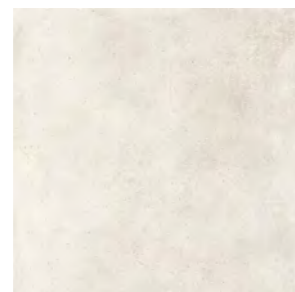

60x60
03501A | Suprema Gesso Nat/Ret
*Antislip



30x60
03492A | Suprema Gesso Nat/Ret

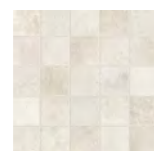

30x30
03509 | Suprema Mosaico Gesso Nat/Ret

Terra

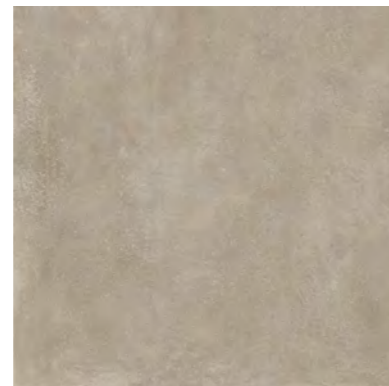

80x80
05254 | Suprema Terra Nat/Ret

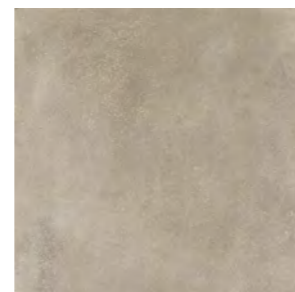

60x60
03503A | Suprema Terra Nat/Ret
*Antislip



30x60
03494A | Suprema Terra Nat/Ret

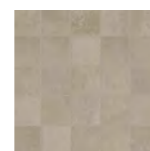

30x30
03512 | Suprema Mosaico Terra Nat/Ret

Sabbia

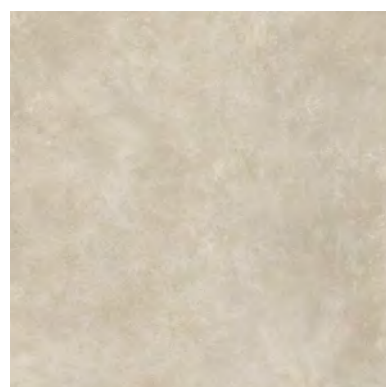

80x80
05253 | Suprema Sabbia Nat/Ret

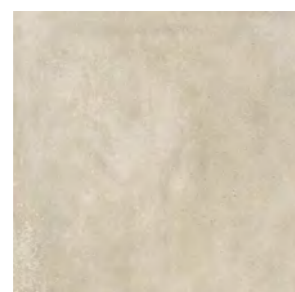

60x60
03502A | Suprema Sabbia Nat/Ret
03893A | Antislip/Ret



30x60
03493A | Suprema Sabbia Nat/Ret

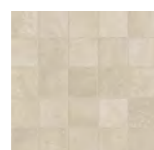

30x30
03511 | Suprema Mosaico Sabbia Nat/Ret

Cenere

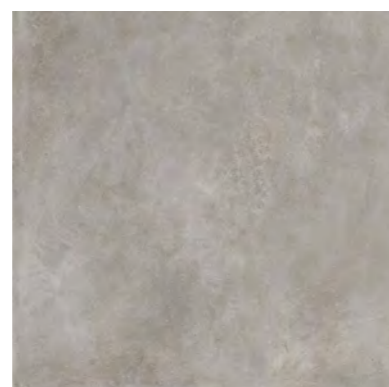

80x80
05255 | Suprema Cenere Nat/Ret

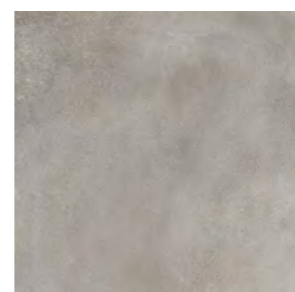

60x60
03504A | Suprema Cenere Nat/Ret
*Antislip

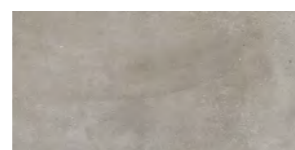

30x60
03495A | Suprema Cenere Nat/Ret

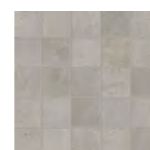

30x30
03513 | Suprema Mosaico Cenere Nat/Ret

Imballi

Packing
Verpackung
Emballage

Formati Sizes		± MM	Pezzi Scatola Pieces/Box Stck/Karton Carreaux/Boîte	Mq/Scatola Sqmt/Box Qm/Karton M2/Boîte	Kg/Scatola Kgs/Box Kg/Karton Kg/Boîte	Scatole/Paletta Boxes/Pallet Karton/Palette Boîte/Palette	Mq/Paletta Sqmt/Pallet Qm/Pallet M2/Palette	Kg/Paletta Kgs/Pallet Kg/Pallet Kg/Palette	Formato Paletta Size Pallet Format Pallet Dim. Palette
80x80 (31½"x31½") Nat/Ret	P	8,5	2	1,28	24,50	54	69,12	1323	124x80x96
60x60 (24"x24") Nat/Ret - Antislip/Ret	P	8,5	4	1,44	26,00	40	57,60	1040	122x82x75
30x60 (12"x24") Nat/Ret	P	8,5	7	1,26	22,50	48	60,48	1080	120x80x75
30x30 (12"x12") Mosaico Nat/Ret	P	8,5	5	0,45	8,50	60	-	-	-
Pezzi Speciali / Special Pieces									
4,5x60 (1¼"x24") Battiscopa Nat/Ret	P	8,5	14	0,378	8,00	80	-	-	-

Riepilogo Gamma

Collection
Serie
Gamme

	Formati Sizes						Mosaico 30x30 - 12"x12"	Battiscopa 4,5x60 - 1¼"x24"
		80x80 31½"x31½"	60x60 24"x24"	30x60 12"x24"	EN 16165C	EN 16165A		
Gesso	Nat/Ret	05252	03501A	03492A	V2	R9	03509	03518
	*Antislip/Ret							
Sabbia	Nat/Ret	05253	03502A	03493A	V2	R9	03511	03519
	Antislip/Ret		03893A			R11	A+B+C	
Terra	Nat/Ret	05254	03503A	03494A	V2	R9	03512	03521
	*Antislip/Ret							
Cenere	Nat/Ret	05255	03504A	03495A	V2	R9	03513	03522
	*Antislip/Ret							

Concrete

Lo studio di design per la collezione Concrete trae ispirazione dalla lavorazione del cemento rasato per superfici industriali. Concrete è una superficie dal mood minimale ed allo stesso tempo profondo e ricercato.

The design study for the Concrete collection takes its inspiration from the working of smoothed concrete for industrial surfaces. Concrete is a surface with a minimal and at the same time deep and elegant mood.

Die Designstudie für die Kollektion Concrete ist an der Optik glattgeputzten Betons für Industrieflächen inspiriert. Concrete erzeugt eine minimalistisch und zugleich intensiv und edel wirkende Oberfläche.

Pour la collection Concrete, le design s'inspire du béton ciré utilisé pour la réalisation des surfaces industrielles. Concrete est une surface à l'aspect à la fois essentiel, profond et raffiné.

5

Colori
Colours
Farben
Couleurs

White



Taupe



Warm Grey



Light Grey



Black



7

Formati
Sizes
Formate
Formats

120×120

48"×48"



60×120

24"×48"



80×80

31½"×31½"



60,4×60,4
60×60

24"×24"



30,1×60,4
30×60

12"×24"



2

Superfici
Surfaces
Oberflächen
Surfaces

Naturale

Grip

i

Effetto Cemento
Cement look
Betonoptik
Effet Béton

Rivestimento
Wall Tiles
Wandfliesen
Revêtement

Pavimento
Floor Tiles
Bodenfliesen
Sol

Gres fine porcellanato ad impasto colorato
Coloured-body fine porcelain stoneware
Feinsteinzeug aus farbiger Masse
Grès cérame fin à pâte colorée

Tecnologia digitale
Digital technology
Digital Technologie
Technologie numérique

White

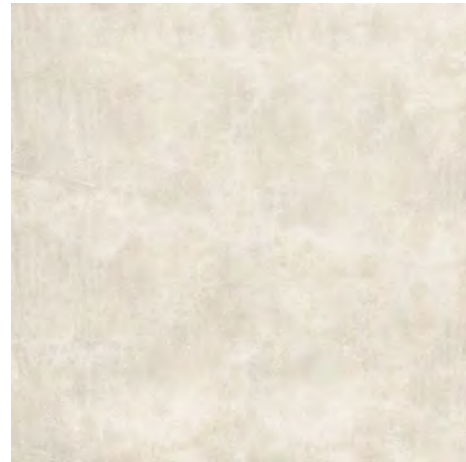

120x120
05298 | Concrete White Nat/Ret

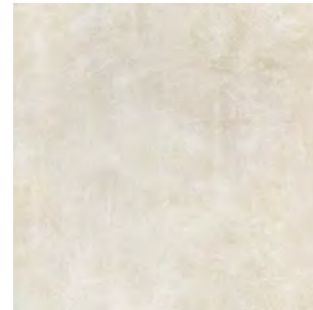

80x80
03669A | Concrete White Nat/Ret

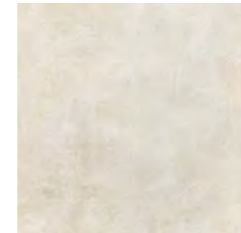

60,4x60,4
03742A | Concrete White Nat
60x60
00934A | Concrete White Nat/Ret



30x30
00983 | Concrete Mosaico
White Nat/Ret

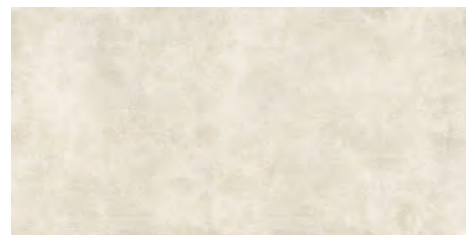

60x120
05305A | Concrete White Nat/Ret

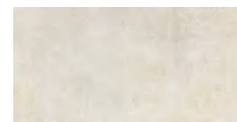

30,1x60,4
03754A | Concrete White Nat
03759B | Concrete White Grip Nat
30x60
00928A | Concrete White Nat/Ret

Taupe



120x120
05349 | Concrete Taupe Nat/Ret

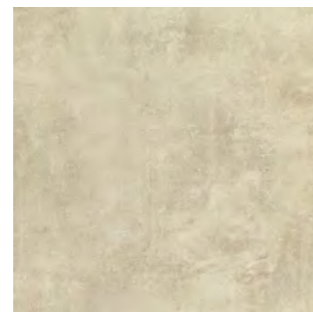

80x80
03671A | Concrete Taupe Nat/Ret
03835B | Concrete Taupe Grip Ret

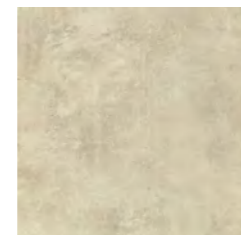

60,4x60,4
03743A | Concrete Taupe Nat
60x60
00935A | Concrete Taupe Nat/Ret
06131 | Concrete Taupe Grip/Ret
02973B | Concrete Taupe Grip/Ret
± 20mm

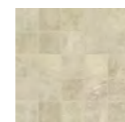

30x30
00984 | Concrete Mosaico
Taupe Nat/Ret



60x120
05306A | Concrete Taupe Nat/Ret
05583 | Concrete Taupe Grip/Ret ± 20mm



30,1x60,4
03755A | Concrete Taupe Nat
03761B | Concrete Taupe Grip Nat
30x60
00929A | Concrete Taupe Nat/Ret

Warm Grey



120x120
05352 | Concrete Warm Grey Nat/Ret

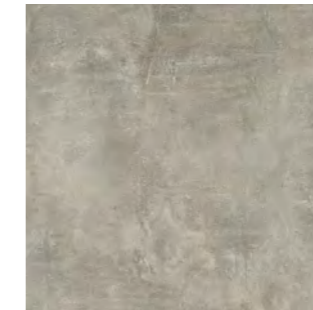

80x80
03673A | Concrete Warm Grey Nat/Ret
03837B | Concrete Warm Grey Grip Ret

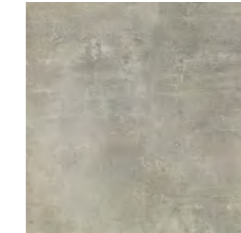

60,4x60,4
03745A | Concrete Warm Grey Nat
60x60
00937A | Concrete Warm Grey Nat/Ret
06133 | Concrete Warm Grey Grip/Ret
02975B | Concrete Warm Grey Grip/Ret
± 20mm

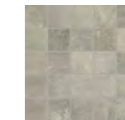

30x30
00986 | Concrete Mosaico
Warm Grey Nat/Ret



60x120
05308A | Concrete Warm Grey Nat/Ret
05584 | Concrete Warm Grey Grip/Ret ± 20mm



30,1x60,4
03757A | Concrete Warm Grey Nat
03763B | Concrete Warm Grey Grip Nat
30x60
00932A | Concrete Warm Grey Nat/Ret

Light Grey



120x120
05351 | Concrete Light Grey Nat/Ret

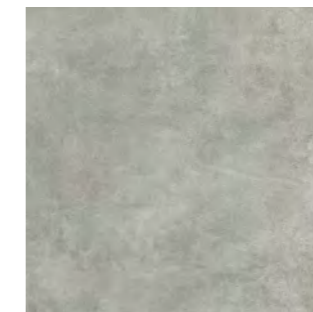

80x80
03672A | Concrete Light Grey Nat/Ret
03836B | Concrete Light Grey Grip Ret

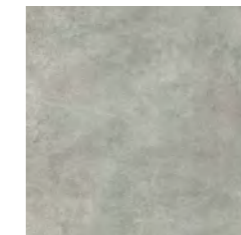

60,4x60,4
03744A | Concrete Light Grey Nat
60x60
00936A | Concrete Light Grey Nat/Ret
06132 | Concrete Light Grey Grip/Ret
02974B | Concrete Light Grey Grip/Ret
± 20mm

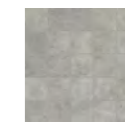

30x30
00985 | Concrete Mosaico
Light Grey Nat/Ret

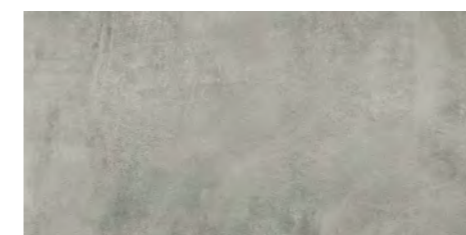

60x120
05307A | Concrete Light Grey Nat/Ret
05585 | Concrete Light Grey Grip/Ret ± 20mm

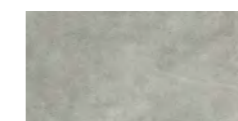

30,1x60,4
03756A | Concrete Light Grey Nat
03762B | Concrete Light Grey Grip Nat
30x60
00931A | Concrete Light Grey Nat/Ret



Step 30x60

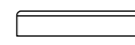

Battiscopa 8x60
Battiscopa 8x80

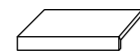

Elemento L 30x60 ± 20

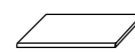

Gradone 30x60 ± 20



Step 30x60

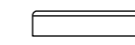

Battiscopa 8x60
Battiscopa 8x80

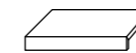

Elemento L 30x60 ± 20

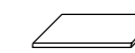

Gradone 30x60 ± 20

Black

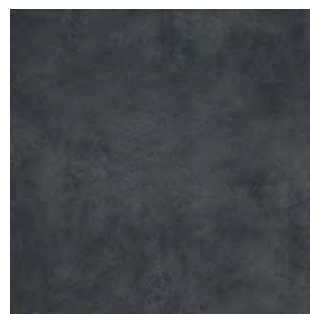

80x80
03674A | Concrete Black Nat/Ret

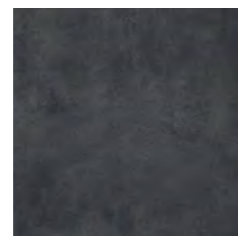

60,4x60,4
03746A | Concrete Black Nat
60x60

00938A | Concrete Black Nat/Ret

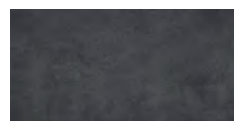

30,1x60,4
03758A | Concrete Black Nat
03764B | Concrete Black Grip Nat



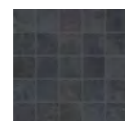



30x60
00933A | Concrete Black Nat/Ret



30x30
00987 | Concrete Mosaico Black Nat/Ret

Imballi

Packing
Verpackung
Emballage

Formato / Size		± MM	 Pezzi/Scatola Pieces/Box Stck/Karton Carreaux/Boite	 Mq/Scatola Sqmt/Box Qm/Karton M2/Boite	 Kg/Scatola Kgs/Box Kg/Karton Kg/Boite	 Scatole/Paletta Boxes/Pallet Karton/Pallet Boite/Palette	 Mq/Paletta Sqmt/Pallet Qm/Pallet M2 /Palette	 Kg/Paletta Kgs/Pallet Kg/Pallet Kg/Palette	 Formato Paletta Size Pallet Format Pallet Dim. Palette
120x120 Nat/Ret	P	8,5	2	2,88	55	24	69,12	1320	135x122x68
80x80 Nat/Ret - Grip/Ret	P	8,5	2	1,28	24,50	54	69,12	1323	124x80x96
60x120 Nat/Ret	P	8,5	2	1,44	28,00	44	63,36	1232	122x100x76
60x120 Grip/Ret	P	20	1	0,72	33,00	36	25,92	1188	122x96x75
60,4x60,4 Nat	P	8,5	4	1,46	26,50	40	58,40	1060	122x82x75
60x60 Nat/Ret	P	8,5	4	1,44	26	40	57,60	1040	122x82x75
60x60 Grip/Ret	P	20	2	0,72	32	32	23,04	1024	120x80x75
30,1x60,4 Nat - Grip	P	8,5	7	1,273	23,00	48	61,10	1104	120x80x75
30x60 Nat/Ret	P	8,5	7	1,26	22,50	48	60,48	1080	120x80x75
30x30 Mosaico (Su Rete)	P	8,5	5	0,45	8,5	60			
Pezzi Speciali / Special Pieces									
8x80 Battiscopa	P	8,5	7	0,448	11	65			
8x60 Battiscopa	P	8,5	10	0,48	11	72			
30x60 Step	P	8,5	6	1,08	22	36			
30x60 Gradone	P	20	2	0,36	17	36			
30x60 Elemento L	P	20	2	0,36	17	30			

Formati Sizes													
	120x120 48"x48"	80x80 31½"x31½"	60x120 24"x48"	60x120 24"x48"	60,4x60,4 24"x24"	60x60 24"x24"	60x60 24"x24"	30,1x60,4 12"x24"	30x60 12"x24"	EN 16165C	EN 16165A	DCOF	
 White	Nat				03742A			03754A	V2	R10	A	> 0,42	
	Nat/Ret	05298	03669A	05305A			00934A			00928A	R11	A+B+C	> 0,42
	Grip Nat												
 Taupe	Nat				03743A			03755A	V2	R10	A	> 0,42	
	Nat/Ret	05349	03671A	05306A			00935A			00929A	R11	A+B+C	> 0,42
	Grip Nat												
 Warm Grey	Nat						05583	06131	02973B	R11	A+B+C	> 0,42	
	Nat/Ret	05352	03673A	05308A			00937A		00932A	R10	A	> 0,42	
	Grip Nat									R11	A+B+C	> 0,42	
 Light Grey	Nat				03744A			03756A	V2	R10	A	> 0,42	
	Nat/Ret	05351	03672A	05307A			00936A			00931A	R11	A+B+C	> 0,42
	Grip Nat												
 Black	Nat						03746A		03758A	V2	R10	A	> 0,42
	Nat/Ret		03674A				00938A		00933A		R11	A+B+C	> 0,42
	Grip Nat												

Formati Sizes		
	Mosaico 30x30 Su Rete 12"x12" (2"x2" Dot)	EN 16165C
 White	Nat	00983
	Nat/Ret	00983
 Taupe	Nat	00984
	Nat/Ret	00984
 Warm Grey	Nat	00986
	Nat/Ret	00986
 Light Grey	Nat	00985
	Nat/Ret	00985
 Black	Nat	00987
	Nat/Ret	00987

Pezzi Speciali Special Pieces				
Battiscopa 8x80 3¼"x31½"	Battiscopa 8x60 3¼"x24"	Step 30x60 12"x24"	Gradone 30x60 12"x24"	Elemento L 30x60 12"x24"
EN 16165C	EN 16165C	EN 16165C	EN 16165C	EN 16165C
00988	01005			
01529	00994			
	00989	01007		
01530	00995		03205	03208
	00992	01009		
01532	00997		03207	03211
	00991	01008		
01531	00996		03206	03209
	00993	01011		
01533	00998			

Pezzi Speciali su Richiesta - Special pieces upon request
Formstücke auf Anfrage - Pièces spéciales sur demande



Gradone Angolare Sx/Dx 20 mm
Grip/Ret 30x60 - 12"x24" EN 16165C

WOOD EFFECT

Effetto Legno / Holzoptik / Effet Bois



- 286 Solonoce PREMIUM /
- 296 Solorovere PREMIUM /
- 308 Fleur De Bois ESSENZA /
- 314 Cottage ESSENZA /
- 318 Soul EMPORIO /

Solonoce

Con Solonoce, Ceramiche Piemme reinterpretava l'essenza del noce in una collezione ceramica per pavimenti e rivestimenti che coniuga bellezza materica e alte prestazioni tecniche.

With Solonoce, Ceramiche Piemme reinterprets the essence of walnut in a ceramic collection for floors and walls, combining the tactile beauty of natural wood with exceptional technical performance.

Mit Solonoce interpretiert Ceramiche Piemme die Essenz des Nussbaums in einer keramischen Kollektion für Böden und Wände neu, die materielle Schönheit und hohe technische Leistung verbindet.

Avec Solonoce, Ceramiche Piemme réinterprète l'essence du noyer dans une collection céramique pour sols et murs, alliant beauté matérielle et hautes performances techniques.

3

Colori
Colours
Farben
Couleurs

Europeo

Canaletto

Americano



3

Formati
Sizes
Formate
Formats

30×120
12"×48"



20×120
8"×48"



10×53
4"×20"



2

Superfici
Surfaces
Oberflächen
Surfaces

Naturale

Grip

i

Effetto Legno
Wood Look
Holzoptik
Effet Bois

Rivestimento
Wall Tiles
Wandfliesen
Revêtement

Pavimento
Floor Tiles
Bodenfliesen
Sol

Gres fine porcellanato ad impasto colorato
Coloured-body fine porcelain stoneware
Feinsteinzeug aus farbiger Masse
Grès cérame fin à pâte colorée

Tecnologia digitale
Digital technology
Digital Technologie
Technologie numérique

Solonoce

Europeo

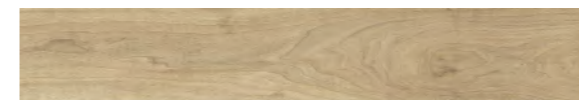

20x120 - 8"x48"

06347 | Solonoce Europeo Nat/Ret
06359 | Solonoce Europeo Grip/Ret



30x120 - 12"x48"

06353 | Solonoce Europeo Nat/Ret

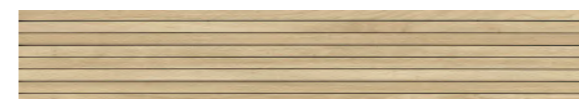

20x120 - 8"x48"

06362 | Solonoce Europeo Cannelé Nat/Ret



10x53 - 4"x20"

06356 | Chevron Europeo Nat/Ret

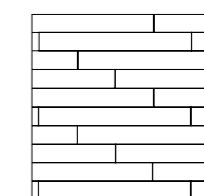

Posa Corretta
Correct Laying

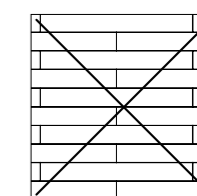

Posa Sconsigliata
Wrong Laying No 50%

Per un risultato di posa ottimale si consiglia di prelevare i listoni da 5 scatole contemporaneamente.

For best installation results, we suggest taking the floorboard tiles from 5 boxes at the same time.



Solonoce

Canaletto



20x120 - 8"x48"

06348 | Solonoce Canaletto Nat/Ret
06360 | Solonoce Canaletto Grip/Ret

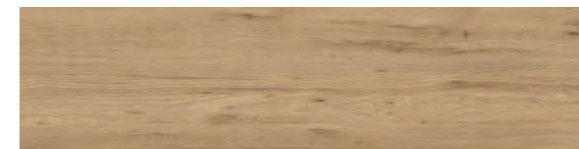

30x120 - 12"x48"

06354 | Solonoce Canaletto Nat/Ret

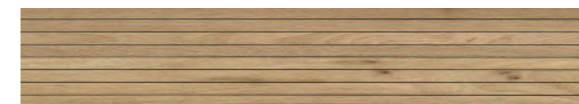

20x120 - 8"x48"

06363 | Solonoce Canaletto Cannelé Nat/Ret



10x53 - 4"x20"

06357 | Chevron Canaletto Nat/Ret

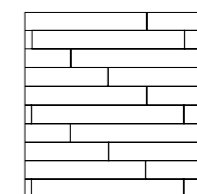

Posa Corretta
Correct Laying

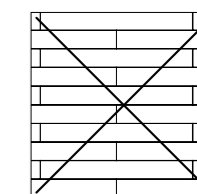

Posa Sconsigliata
Wrong Laying No 50%

Per un risultato di posa ottimale si consiglia di prelevare i listoni da 5 scatole contemporaneamente.

For best installation results, we suggest taking the floorboard tiles from 5 boxes at the same time.



Solonoce

Wood Effect
PREMIUM

Americano



20x120 - 8"x48"

06346 | Solonoce Americano Nat/Ret
06358 | Solonoce Americano Grip/Ret



30x120 - 12"x48"

06352 | Solonoce Americano Nat/Ret



20x120 - 8"x48"

06361 | Solonoce Americano Cannelé Nat/Ret



10x53 - 4"x20"

06355 | Chevron Americano Nat/Ret

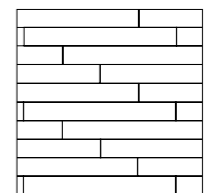



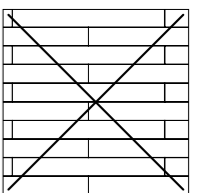



Posa Corretta
Correct Laying





Posa Sconsigliata
Wrong Laying No 50%

Per un risultato di posa ottimale si consiglia di prelevare i listoni da 5 scatole contemporaneamente.

For best installation results, we suggest taking the floorboard tiles from 5 boxes at the same time.

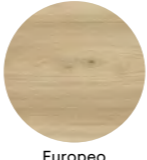
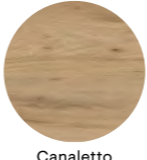
Formati Sizes		± MM	 Pezzi Scatola Pieces/Box Stck/Karton Carreaux/Boîte	 Mq/Scatola Sqmt/Box Qm/Karton M2/Boîte	 Kg/Scatola Kgs/Box Kg/Karton Kg/Boîte	 Scatole/Paletta Boxes/Pallet Karton/Palette Boîte/Palette	 Mq/Paletta Sqmt/Pallet Qm/Pallet M2/Palette	 Kg/Paletta Kgs/Pallet Kg/Pallet Kg/Palette	 Formato Paletta Size Pallet Format Pallet Dim. Palette
30x120 (12"x48") Nat/Ret	P	8,5	4	1,44	28,00	36	51,84	1008	122x95x62
20x120 (8"x48") Nat/Ret - Grip/Ret	P	8,5	5	1,200	23,00	48	57,6	1104	122x82x75
20x120 (8"x48") Canneté Nat/Ret	P	8,5	4	0,960	18,00	36	34,56	648	122x82x75
10x53 (4"x20") Nat/Ret	P	8,5	12	0,636	11,90	60	38,16	714	120x80x75
Pezzi Speciali / Special Pieces									
4,5x120 (1 1/4"x48") Battiscopa Nat/Ret	P	8,5	6	0,324	6,10	48	-	-	-

Formati Sizes						EN 16165C	EN 16165A	DCOF	Stucchi Consigliati Recommended grouts Joints recommandés Empfohlene Fugen	Pezzi Speciali Special Pieces
 Europeo	Nat/Ret	06353	06347	06362	06356	R10	A+B	>0.42	Kerakoll KK151	Battiscopa 4,5x120 1 1/4"x48"
	Grip/Ret		06359							
 Canaletto	Nat/Ret	06354	06348	06363	06357	R10	A+B	>0.42	Kerakoll KK153	
	Grip/Ret		06360							
 Americano	Nat/Ret	06352	06346	06361	06355	R10	A+B	>0.42	Mapei 142	06403
	Grip/Ret		06358							

Solorovere

Naturale, fiammato, grintoso o vintage?
Solorovere, una collezione di doghe in gres porcellanato che esprime l'essenza del rovere in quattro diverse declinazioni.

Natural, flamed, bold or vintage?
Solorovere, a collection of porcelain stoneware slates that expresses the essence of oak in four variations.

Natürlich, geflammt, kräftig oder vintage?
Solorovere, eine Kollektion von Feinsteinzeugleisten, die die Essenz der Eiche in vier verschiedenen Abweichungen zum Ausdruck bringt.

Naturel, Flammé, Moderne ou Vintage ?
Solorovere, une collection de lames parquet en grès cérame qui exprime l'essence du chêne en quatre variantes différentes.

4

Colori
Colours
Farben
Couleurs

Pure



Flamed



Loft



Vintage



3

Formati
Sizes
Formate
Formats

30×120
12"×48"



20×120
8"×48"



10×53
4"×20"



3

Superfici
Surfaces
Oberflächen
Surfaces

Naturale

Antislip

Grip

i

Effetto Legno
Wood Look
Holzoptik
Effet Bois

Rivestimento
Wall Tiles
Wandfliesen
Revêtement

Pavimento
Floor Tiles
Bodenfliesen
Sol

Gres fine porcellanato ad impasto colorato
Coloured-body fine porcelain stoneware
Feinsteinzeug aus farbiger Masse
Grès cérame fin à pâte colorée

Tecnologia digitale
Digital technology
Digital Technologie
Technologie numérique

▶ WATCH THE VIDEO



Pure



20x120 - 8x48"
05388 | Pure Nat/Ret

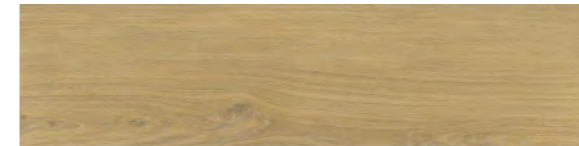

30x120 - 12x48"
06164 | Pure Nat/Ret



20x120 - 8x48"
05405 | Flamed Cannelé Nat/Ret



10x53 - 4x20"
05399 | Chevron Pure Nat/Ret

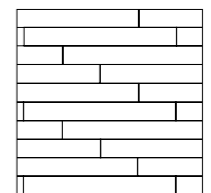

Posa Corretta
Correct Laying

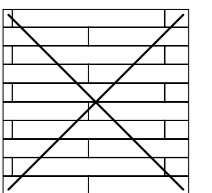

Posa Sconsigliata
Wrong Laying No 50%

Per un risultato di posa ottimale si consiglia di prelevare i listoni da 5 scatole contemporaneamente.

For best installation results, we suggest taking the floorboard tiles from 5 boxes at the same time.



Solorovere

Wood Effect
PREMIUM

Flamed



20x120 - 8x48"
05389 | Flamed Nat/Ret
05393 | Flamed Antislip/Ret

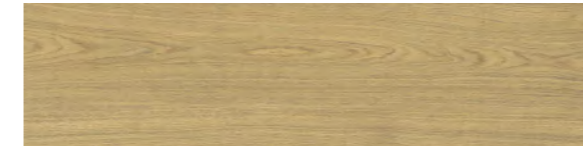

30x120 - 12x48"
06165 | Flamed Nat/Ret



20x120 - 8x48"
05405 | Flamed Cannelé Nat/Ret



10x53 - 4x20"
05401 | Chevron Flamed Nat/Ret

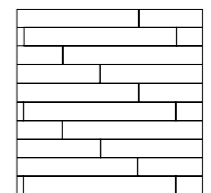

Posa Corretta
Correct Laying

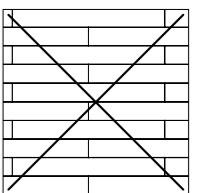

Posa Sconsigliata
Wrong Laying No 50%

Per un risultato di posa ottimale si consiglia di prelevare i listoni da 5 scatole contemporaneamente.

For best installation results, we suggest taking the floorboard tiles from 5 boxes at the same time.

Solorovere

Loft



20x120 - 8"x48"

05391 | Loft Nat/Ret
05394 | Loft Antislip/Ret



30x120 - 12"x48"

06166 | Loft Nat/Ret
05596 | Loft Grip/Ret \pm 20mm



20x120 - 8"x48"

05404 | Loft Cannelé Nat/Ret



10x53 - 4"x20"

05402 | Chevron Loft Nat/Ret

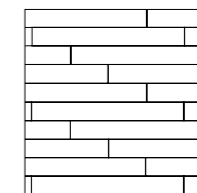

Posa Corretta
Correct Laying

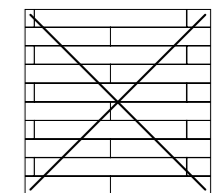

Posa Sconsigliata
Wrong Laying No 50%

Per un risultato di posa ottimale si consiglia di prelevare i listoni da 5 scatole contemporaneamente.

For best installation results, we suggest taking the floorboard tiles from 5 boxes at the same time.



Solorovere

Vintage



20x120 - 8"x48"
05392 | Vintage Nat/Ret



30x120 - 12"x48"
06167 | Vintage Nat/Ret
05597 | Vintage Grip/Ret ± 20mm



20x120 - 8"x48"
05404 | Loft Cannelé Nat/Ret



10x53 - 4"x20"
05403 | Chevron Vintage Nat/Ret

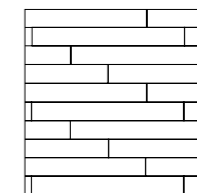

Posa Corretta
Correct Laying

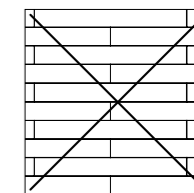

Posa Sconsigliata
Wrong Laying No 50%

Per un risultato di posa ottimale si consiglia di prelevare i listoni da 5 scatole contemporaneamente.

For best installation results, we suggest taking the floorboard tiles from 5 boxes at the same time.

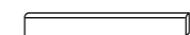

Imballi

Packing
Verpackung
Emballage

Formati Sizes		± MM	Pezzi Scatola Pieces/Box Stck/Karton Carreaux/Boîte	Mq/Scatola Sqmt/Box Qm/Karton M2/Boîte	Kg/Scatola Kgs/Box Kg/Karton Kg/Boîte	Scatole/Paletta Boxes/Pallet Karton/Palette Boîte/Palette	Mq/Paletta Sqmt/Pallet Qm/Pallet M2/Palette	Kg/Paletta Kgs/Pallet Kg/Pallet Kg/Palette	Formato Paletta Size Pallet Format Pallet Dim. Palette
30x120 (12"x48") Nat/Ret	P	8,5	4	1,44	28,00	36	51,84	1008	122x95x62
30x120 (12"x48") Grip/Ret	P	20	2	0,72	33,05	36	25,92	1189,8	122x95x70
20x120 (8"x48") Nat/Ret - Antislip/Ret	P	8,5	5	1,200	23,00	48	57,6	1104	122x82x75
20x120 (8"x48") Canneté Nat/Ret	P	8,5	4	0,960	18,00	36	34,56	648	122x82x75
10x53 (4"x20") Nat/Ret	P	8,5	12	0,636	11,90	60	38,16	714	120x80x75
Pezzi Speciali / Special Pieces									
4,5x120 (1¼"x48") Battiscopa Nat/Ret	P	8,5	6	0,324	6,10	48	-	-	-

Riepilogo Gamma

Collection
Serie
Gamme

[PDF Merchandising](#)

Formati Sizes		± MM								UPEC			Stucchi Consigliati Recommended grouts Joints recommandés Empfohlene Fugen	Pezzi Speciali Special Pieces		
										EN 16165C	EN 16165A	DCOF				
Pure	Nat/Ret	06164									V2	R10	A+B	>0.42	Mapei 188	05395
Flamed	Nat/Ret	06165									V2	R10	A+B	>0.42	Mapei 188	05396
	Antislip/Ret											R11	A+B+C	>0.42		
Loft	Nat/Ret	06166										R10	A+B	>0.42	Mapei 188	05397
	Antislip/Ret										V2	R11	A+B+C	>0.42		
Grip/Ret												R11	A+B+C	>0.42		
Vintage	Nat/Ret	06167									V3	R10	A+B	>0.42	Mapei 188	05398
	Grip/Ret											R11	A+B+C	>0.42		

Fleur de Bois

Una collezione ispirata ad un mix essenze di noce americano e di noce nazionale sapientemente miscelate tra loro, alla ricerca dell'equilibrio per coglierne le migliori espressioni estetiche; quelle date dalle tipiche venature longitudinali con andamento regolare ed elegante.

A collection inspired by a mix of woods types – hickory and Italian walnut – skilfully blended in order to achieve a balance and highlight their best aesthetic expressions; those produced by typical longitudinal grains with a regular and elegant pattern.

Eine Kollektion, die sich an einem gelungenen Mix aus amerikanischem und europäischem Walnussbaum inspiriert, wobei die schönsten Ausdrucksformen zu einem ausgewogenen Ganzen komponiert wurden.

Cette collection s'inspire d'un mélange d'essences de noyer d'Amérique et de noyer d'Italie, savamment associées l'une à l'autre en un équilibre qui exalte leurs plus belles expressions esthétiques.

8

Colori
Colours
Farben
Couleurs

Blanc

Gris

Naturel

Beige

Brun

Glacé

Miel

Chocolat

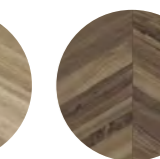
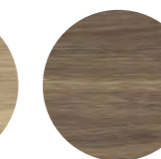
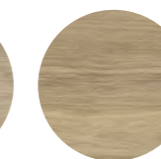
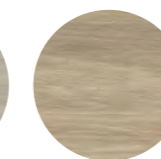

2

Formati
Sizes
Formate
Formats

60×120
24"×48"



20×120
8"×48"



2

Superfici
Surfaces
Oberflächen
Surfaces

Naturale

Antislip

i

Effetto Legno
Wood Look
Holzoptik
Effet Bois

Rivestimento
Wall Tiles
Wandfliesen
Revêtement

Pavimento
Floor Tiles
Bodenfliesen
Sol

Gres fine porcellanato ad impasto colorato
Coloured-body fine porcelain stoneware
Feinsteinzeug aus farbiger Masse
Grès cérame fin à pâte colorée

Tecnologia digitale
Digital technology
Digital Technologie
Technologie numérique

Ripresa grafica tra le diverse lastre rettificata contenuta entro le tolleranze previste dalla norma. Per un corretto allineamento si consiglia di utilizzare una fuga di 2 mm.
Graphic representation between the rectified tiles is contained within the tolerances provided by the standard. For a correct alignment it is recommended to use a 2 mm joint.
Grafische Darstellung zwischen den verschiedenen rektifizierten Platten innerhalb der in der Norm vorgesehenen Toleranzen. Für eine korrekte Anpassung wird eine Fuge von 2mm empfohlen.
Reproduction graphique entre les différents carreaux rectifiés dans les limites des tolérances prévues par la norme. Pour un alignement correct, il est recommandé d'utiliser joints de 2 mm.

Fleur de Bois

Blanc



20x120
03015B | Fleur De Bois Blanc Nat/Ret
03458B | Fleur De Bois Blanc Antislip/Ret



20x20
02052 | Fleur de Bois Blanc Tarsia Nat/Ret

Gris



20x120
03014B | Fleur De Bois Gris Nat/Ret
03457B | Fleur De Bois Gris Antislip/Ret



20x20
02051 | Fleur de Bois Gris Tarsia Nat/Ret

Naturel

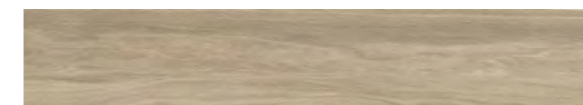

20x120
03013B | Fleur De Bois Naturel Nat/Ret
03459B | Fleur De Bois Naturel Antislip/Ret



20x20
02053 | Fleur de Bois Naturel Tarsia Nat/Ret

Beige



20x120
03016B | Fleur De Bois Beige Nat/Ret
03461B | Fleur De Bois Beige Antislip/Ret



20x20
02054 | Fleur de Bois Beige Tarsia Nat/Ret

Brun



20x120
03017B | Fleur De Bois Brun Nat/Ret
03462B | Fleur De Bois Brun Antislip/Ret

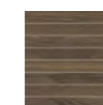

20x20
02055 | Fleur de Bois Brun Tarsia Nat/Ret

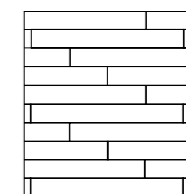

Posa Corretta
Correct Laying

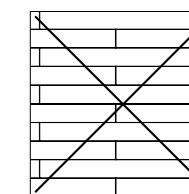

Posa Sconsigliata
Wrong Laying No 50%

Per un risultato di posa ottimale si consiglia di prelevare i listoni da 5 scatole contemporaneamente.

For best installation results, we suggest taking the floorboard tiles from 5 boxes at the same time.

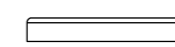
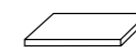

Chevron Glace



60x120
03025B | Chevron Glace Nat/Ret

Chevron Miel



60x120
03024B | Chevron Miel Nat/Ret

Chevron Chocolat

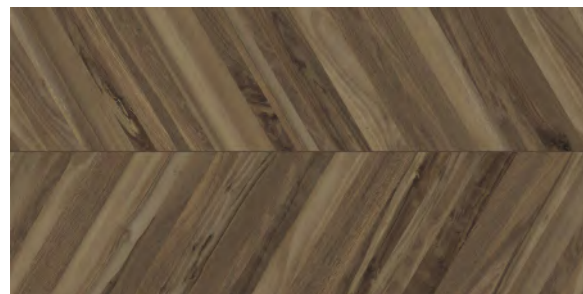

60x120
03026B | Chevron Chocolat Nat/Ret

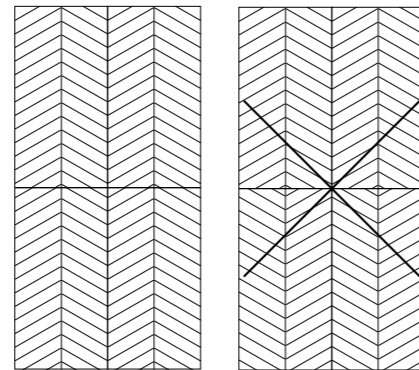

Posa corretta
Correct laying

Posa sconsigliata
Wrong laying

Imballi

Packing
Verpackung
Emballage

Formato / Size		± MM	Pezzi Scatola Pieces/Box Stck/Karton Carreaux/Boîte	Mq/Scatola Sqmt/Box Qm/Karton M2/Boîte	Kg/Scatola Kgs/Box Kg/Karton Kg/Boîte	Scatole/Paletta Boxes/Pallet Karton/Palette Boîte/Palette	Mq/Paletta Sqmt/Pallet Qm/Pallet M2/Palette	Kg/Paletta Kgs/Pallet Kg/Pallet Kg/Palette	Formato Paletta Size Pallet Format Pallet Dim. Palette
20x120 (8"x48") Nat/Ret - Antislip/Ret	P	8,5	5	1,200	23,00	48	57,60	1104	122x82x75
60x120 (24"x48") Chevron Nat/Ret	P	9,5	2	1,44	31,00	36	51,84	1116	122x95x76
20x20 (8"x8") Tarsia Nat/Ret	P	9,5	6	0,240	5,00	105	-	-	-
Pezzi Speciali / Special Pieces									
20x120 (8"x48") Step Nat/Ret	P	8,5	4	0,960	22,70	36	-	-	-
6,5x120 (2½"x48") Battiscopa Nat/Ret	P	8,5	8	0,624	14,00	48	-	-	-

Riepilogo Gamma

Collection
Serie
Gamme

Formati Sizes		20x120 8"x48"	Chevron 60x120 24"x48"				Tarsia 20x20 8"x8"	Pezzi Speciali Special Pieces		
		± 8,5	± 9,5	EN 16165C	EN 16165A	DCOF		Step 20x120 8"x48"	Battiscopa 6,5x120 2½"x48"	
	Nat/Ret	03015B		V3	R9	A	>0.42	02052	02076	02088
	Antislip/Ret	03458B			R11	A+B+C	>0.42			
	Nat/Ret	03014B		V3	R9	A	>0.42	02051	02075	02087
	Antislip/Ret	03457B			R11	A+B+C	>0.42			
	Nat/Ret	03013B		V3	R9	A	>0.42	02053	02077	02089
	Antislip/Ret	03459B			R11	A+B+C	>0.42			
	Nat/Ret	03016B		V3	R9	A	>0.42	02054	02078	02091
	Antislip/Ret	03461B			R11	A+B+C	>0.42			
	Nat/Ret	03017B		V3	R9	A	>0.42	02055	02079	02092
	Antislip/Ret	03462B			R11	A+B+C	>0.42			
	Nat/Ret		03025B		R9	A	>0.42			
	Nat/Ret		03024B		R9	A	>0.42			
	Nat/Ret		03026B		R9	A	>0.42			

Cottage

Sensazioni materiche, venature disegnate dal tempo e tonalità naturali: Cottage riveste gli spazi del vivere contemporaneo con l'essenza dei legnami più pregiati.

Tactile sensations, veins designed by time and natural colour shades: Cottage covers contemporary living spaces with the essence of the most precious woods.

Materische Empfindungen, von der Zeit gezeichnete Äderungen und natürliche Farbtöne: Cottage kleidet unsere modernen Lebensräume mit der Seele der edelsten Hölzer.

Des sensations de matière forte, des veinages tracés par le temps et des teintes naturelles; Cottage habille les espaces de vie contemporains avec l'essence des bois les plus précieux

8

Colori
Colours
Farben
Couleurs

Tiglio



Acacia



Olmo



Ulivo

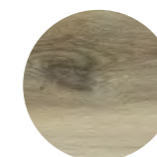

Cipresso

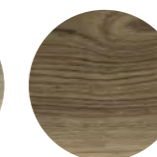

Seraya

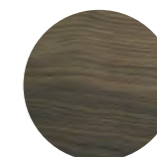

Larice



Carpino

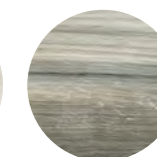

1

Formati
Sizes
Formate
Formats

20×120

8"×48"

1

Superfici
Surfaces
Oberflächen
Surfaces

Naturale

i

Effetto Legno
Wood Look
Holzoptik
Effet Bois

Rivestimento
Wall Tiles
Wandfliesen
Revêtement

Pavimento
Floor Tiles
Bodenfliesen
Sol

Gres Fine porcellanato smaltato
Glazed porcelain Stoneware
Glasierte Feinsteinzeug
Grès cérame émaillé

Tecnologia digitale
Digital technology
Digital Technologie
Technologie numérique

Tiglio

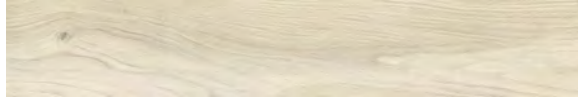

20x120

03019B | Cottage Tiglio Nat/Ret

Cipresso

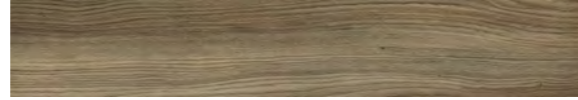

20x120

02992B | Cottage Cipresso Nat/Ret

Acacia



20x120

03022B | Cottage Acacia Nat/Ret

Seraya



20x120

03021B | Cottage Seraya Nat/Ret

Olmo



20x120

02991B | Cottage Olmo Nat/Ret

Larice



20x120

03023B | Cottage Larice Nat/Ret

Ulivo



20x120

03018B | Cottage Ulivo Nat/Ret

Carpino



20x120

03020B | Cottage Carpino Nat/Ret



15x15

00278 | Maiolica Blu Ret



15x15

00279 | Maiolica Cotto Ret



15x15

00281 | Maiolica Grigio Ret

Imballi

Packing
Verpackung
Emballage

Formato / Size		± MM	Pezzi/Scatola Pieces/Box Stck/Karton Carreaux/Boîte	Mq/Scatola Sqmt/Box Qm/Karton M2/Boîte	Kg/Scatola Kgs/Box Kg/Karton Kg/Boîte	Scatole/Paletta Boxes/Pallet Karton/Pallet Boîte/Palette	Mq/Paletta Sqmt/Pallet Qm/Pallet M2/Palette	Kg/Paletta Kgs/Pallet Kg/Pallet Kg/Palette	Formato Paletta Size Pallet Format Pallet Dim. Palette
20x120 Nat/Ret	P	8,5	5	1.200	23	48	57,60	1104	122*82*75
15x15 Maiolica Ret	P	9,5	6	0,135	3,4	55			
Pezzi Speciali / Special Pieces									
6,5x120 Battiscopa	P	8,5	8	0,624	14	48			

Riepilogo Gamma

Collection
Serie
Gamme

Formati Sizes		± 8,5	EN 16165C	EN 16165A	DCOF	Pezzi Speciali Special Pieces				
						Battiscopa 6,5x120 - 2½"x48"	Maiolica 15x15 - 6"x6"			
Tiglio	Nat/Ret	03019B	V3	R10	A+B	> 0,42	00951	Grigio	Nat/Ret	00281
Acacia	Nat/Ret	03022B	V3	R10	A+B	> 0,42	00957	Blu	Nat/Ret	00278
Olmo	Nat/Ret	02991B	V3	R10	A+B	> 0,42	00955	Cotto	Nat/Ret	00279
Ulivo	Nat/Ret	03018B	V3	R10	A+B	> 0,42	00953			
Cipresso	Nat/Ret	02992B	V3	R10	A+B	> 0,42	00954			
Seraya	Nat/Ret	03021B	V3	R10	A+B	> 0,42	00956			
Larice	Nat/Ret	03023B	V3	R10	A+B	> 0,42	00958			
Carpino	Nat/Ret	03020B	V3	R10	A+B	> 0,42	00952			

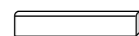

Soul

L'essenza regina di tutti i legni è il rovere di quercia, capace di esprimersi in una moltitudine di possibilità. La ricerca Piemme ne ha indagato l'anima nel profondo, liberandola in tre principali declinazioni: naturale, rustico, recuperato.

The queen of wood is oak and it can express itself in a multitude of ways. Piemme research delved into its soul and declined its multifaceted nature in three ways: natural, rustic and reclaimed.

Die edelste aller Holzarten ist das Eichenholz, das seine Ausstrahlungskraft auf vielfältige Art zum Ausdruck bringen kann. Die Piemme Forschung hat sich eingehend mit dem Wesen dieses Holzes befasst und dieses in drei Hauptvarianten optisch umgesetzt: natürlich, rustikal, und gealtert.

Le roi de tous les bois est le chêne rouvre, en mesure d'adopter une multitude d'expressions différentes. La recherche Piemme a fouillé au plus profond de son âme pour en tirer trois principales formes: naturelle, rustique, de récupération.

4

Colori
Colours
Farben
Couleurs

Pure

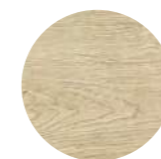

Nordic



Knots

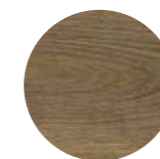

Reclaimed

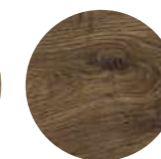

1

Formati
Sizes
Formate
Formats

20×120
8"×48"



2

Superfici
Surfaces
Oberflächen
Surfaces

Naturale Grip

i

Effetto Legno
Wood Look
Holzoptik
Effet Bois

Rivestimento
Wall Tiles
Wandfliesen
Revêtement

Pavimento
Floor Tiles
Bodenfliesen
Sol

Gres fine porcellanato ad impasto colorato
Coloured-body fine porcelain stoneware
Feinsteinzeug aus farbiger Masse
Grès cérame fin à pâte colorée

Tecnologia digitale
Digital technology
Digital Technologie
Technologie numérique

▶ WATCH THE VIDEO

Pure



20x120
02947B | Soul Pure Nat/Ret

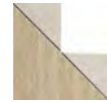

20x15
02989 | Soul Kaleido Light Nat/Ret



19x22
02988 | Soul Mosaico Rolo Nat/Ret

Nordic



20x120
02948B | Soul Nordic Nat/Ret

Knots



20x120
02951B | Soul Knots Nat/Ret
03094B | Soul Knots Grip/Ret

Reclaimed



20x120
02953B | Soul Reclaimed Nat/Ret
03095B | Soul Reclaimed Grip/Ret



20x15
02990 | Soul Kaleido Dark Nat/Ret



20x120
02986B | Soul Shield Nat/Ret

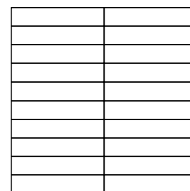

Posa Corretta (Shield)
(Shield) correct laying

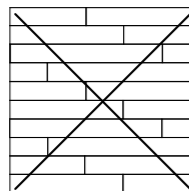

Posa Sfalsata non consentita (Shield)
(Shield) wrong laying

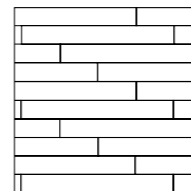

Posa Corretta Fondi 20x119,5
Correct Laying of Tiles 20x119,5

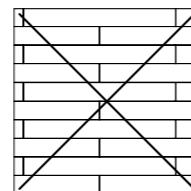

Posa Sconsigliata Fondi 20x119,5
Wrong Laying No 50% Tiles 20x119,5

Per un risultato di posa ottimale si consiglia di prelevare i listoni da 5 scatole contemporaneamente.

For best installation results, we suggest taking the floorboard tiles from 5 boxes at the same time.

Imballi

Packing
Verpackung
Emballage

Formati Sizes	± MM	Pezzi Scatola Pieces/Box Stck/Karton Carreaux/Boîte	Mq/Scatola Sqmt/Box Qm/Karton M2/Boîte	Kg/Scatola Kgs/Box Kg/Karton Kg/Boîte	Scatole/Paletta Boxes/Pallet Karton/Palette Boîte/Palette	Mq/Paletta Sqmt/Pallet Qm/Palette M2/Palette	Kg/Paletta Kgs/Pallet Kg/Pallet Kg/Palette	Formato Paletta Size Pallet Format Pallet Dim. Palette	
20x120 (8"x48") Nat/Ret	P	8,5	5	1,200	23,00	48	57,60	1104	122x82x75
20x120 (8"x48") Grip/Ret	P	8,5	5	1,200	23,00	48	57,60	1104	122x82x75
20x120 (8"x48") Shield Nat/Ret	P	8,5	5	1,200	23,00	48	57,60	1104	122x82x75
20x15 (8"x6") Kaleido	P	8,5	25	0,750	15,50	36	-	-	-
19x22 (7½"x8¾") Mosaico Rolo	P	8,5	11	0,46	10,00	30	-	-	-
Pezzi Speciali / Special Pieces									
4,5x120 (1¼"x48") Battiscopa Nat/Ret	P	8,5	6	0,324	8,00	48	-	-	-

Riepilogo Gamma

Collection
Serie
Gamme

Formati Sizes	EN 16165C EN 16165A DCOF				Shield 20x120 8"x48"	Kaleido 20x15 8"x6"	Mosaico Rolo 19x22 7½"x8¾"	Pezzi Speciali Special Pieces		
	20x120 8"x48"	± 8,5	EN 16165C	EN 16165A					DCOF	± 8,5
Pure	Nat/Ret	02947B	V3	R10	A+B	>0.42	02986B	02989	02988	02959A
Nordic	Nat/Ret	02948B	V3	R10	A+B	>0.42	02986B		02988	02960A
Knots	Nat/Ret	02951B	V3	R10	A+B	>0.42	02986B		02988	02961A
	Grip/Ret	03094B		R11	A+B+C	>0.42				
Reclaimed	Nat/Ret	02953B	V3	R10	A+B	>0.42	02986B	02990		02962A
	Grip/Ret	03095B		R11	A+B+C	>0.42				

MARBLE EFFECT

Effetto Marmo / Marmoroptik / Effet Marbre

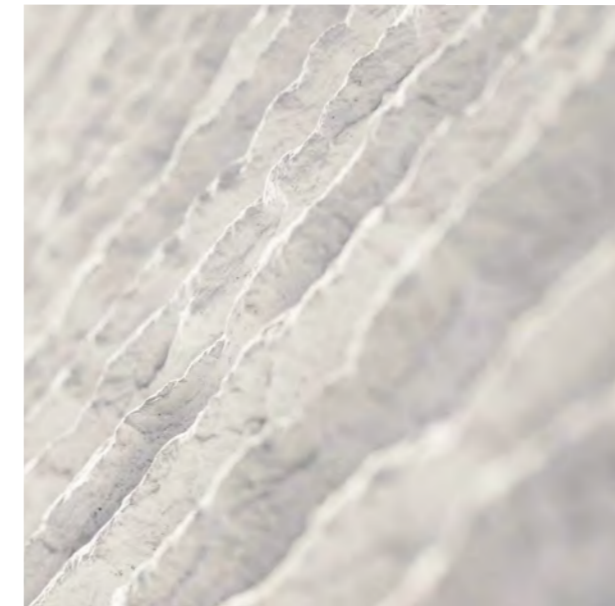

324 Majestic Onyx PREMIUM /

338 Majestic Pure Selection PREMIUM /

350 Majestic PREMIUM /

Majestic Onyx

Pregiato e delicato al tempo stesso, traslucido e cromaticamente perfetto grazie alle sue sfumature. Grandi qualità dell'onice reinterpretate e perfezionate per rendere la Majestic Onyx una serie molto versatile, ideale per ambienti eleganti e contemporanei.

Both precious and delicate with its translucent and chromatically perfected nuances, Majestic Onyx is a very versatile series, ideal for elegant and contemporary environments.

Kostbar und zart zugleich, durchscheinend und chromatisch perfekt dank seiner Nuancen. Die großartigen Eigenschaften von Onyx wurden neu interpretiert und perfektioniert, um Majestic Onyx zu einer sehr vielseitigen Serie zu machen, ideal für elegante und moderne Umgebungen, in denen Farbe vorherrscht.

Précieux et délicat au même temps, translucide et chromatiquement parfait grâce à ses nuances. De grandes qualités de l'onix réinterprétées et perfectionnées pour faire de la Majestic Onyx une série très polyvalente, idéale pour les environnements élégants et contemporains où la couleur prévaut.

5

Colori
Colours
Farben
Couleurs



3

Formati
Sizes
Formate
Formats

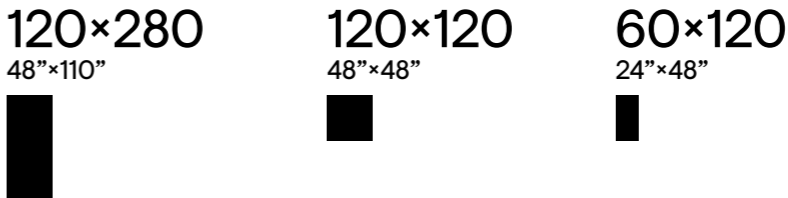

1

Superfici
Surfaces
Oberflächen
Surfaces

Levigato

i

- Effetto Marmo
Marble Look
Marmoroptik
Effet Marbre
- Rivestimento
Wall Tiles
Wandfliesen
Revêtement
- Pavimento
Floor Tiles
Bodenfliesen
Sol
- Gres fine porcellanato
Fine porcelain stoneware
Feinsteinzeug
Grès cérame fin
- Tecnologia digitale
Digital technology
Digital technologie
Technologie numérique

Majestic Onyx

Pearl White

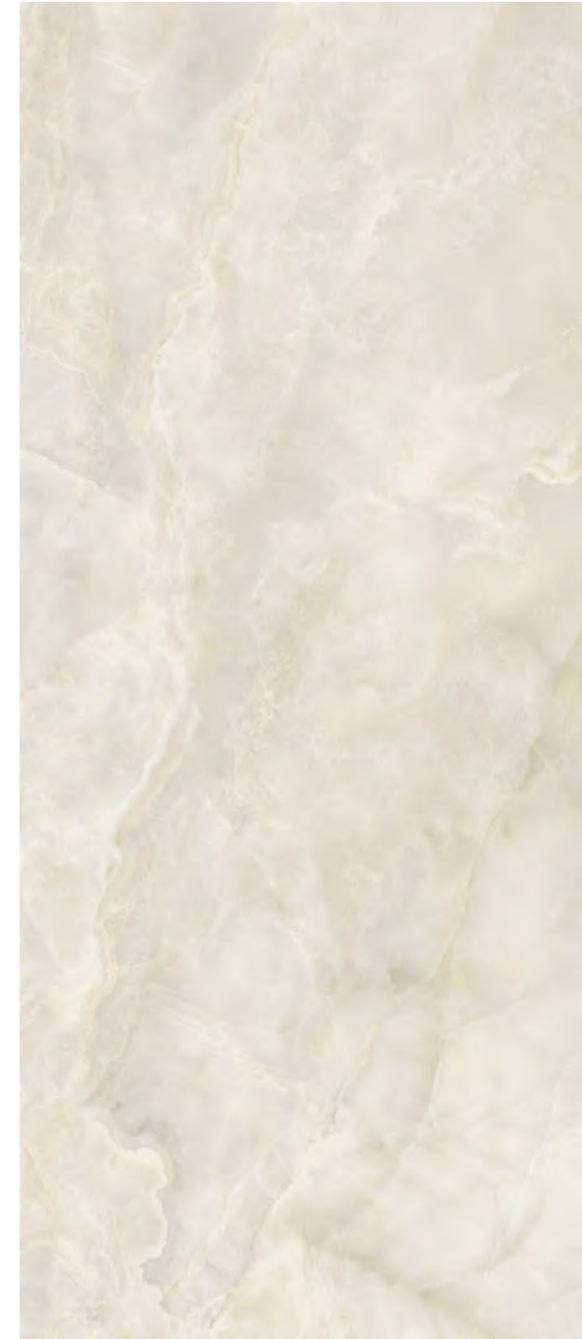

120x280
05456 | Majestic Onyx Pearl White Lev/Ret



120x120
05452 | Majestic Onyx Pearl White Lev/Ret

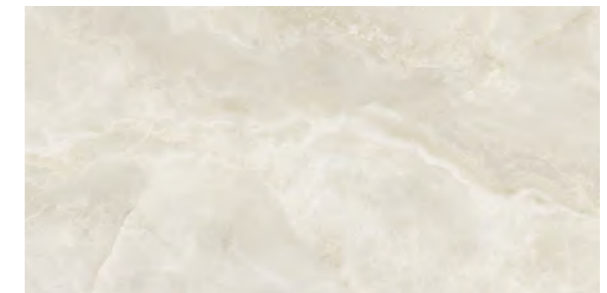

60x120
05447A | Majestic Onyx Pearl White Lev/Ret

Majestic Onyx

Crystal Beige

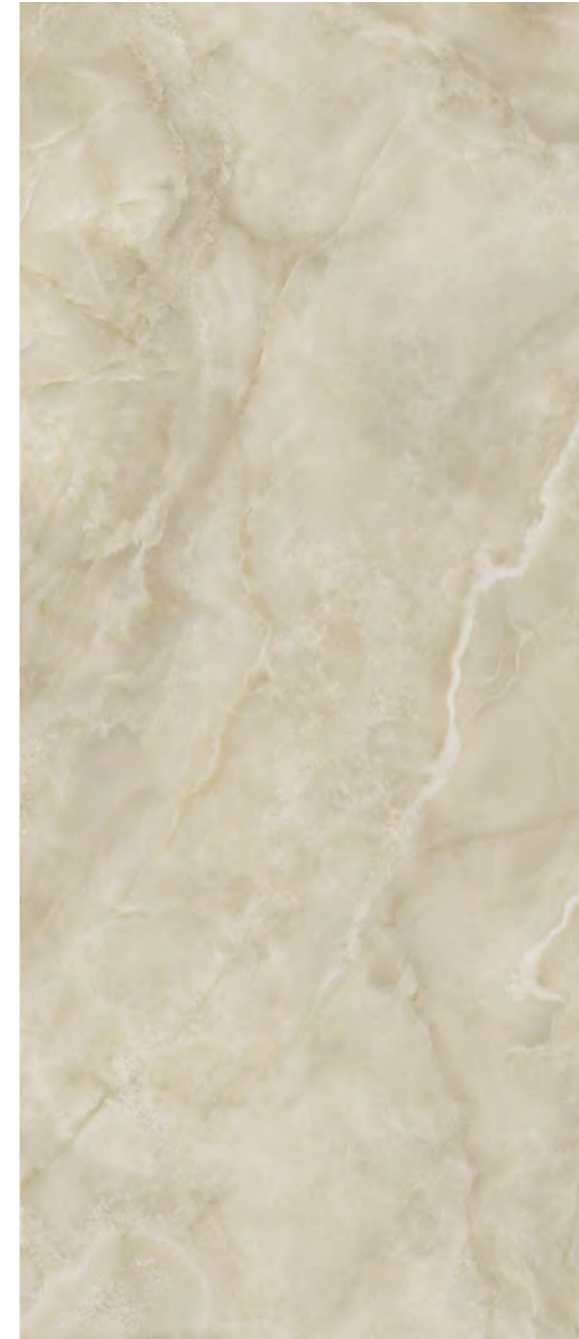

120x280
05458 | Majestic Onyx Crystal Beige Lev/Ret

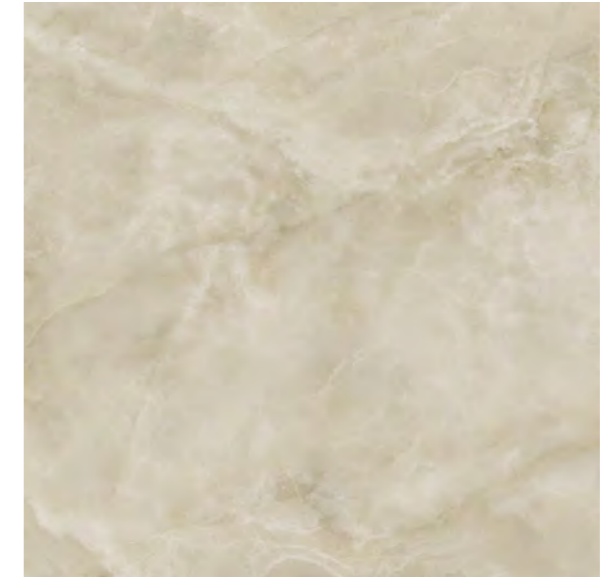

120x120
05454 | Majestic Onyx Crystal Beige Lev/Ret

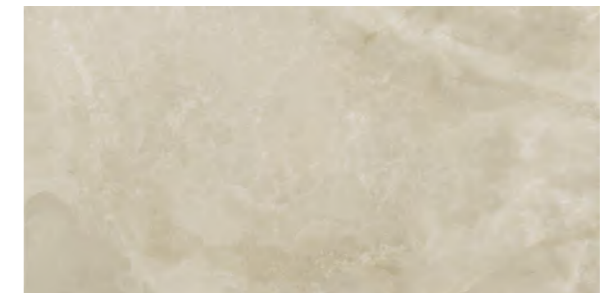

60x120
05449A | Majestic Onyx Crystal Beige Lev/Ret

Majestic Onyx

Smoky Grey

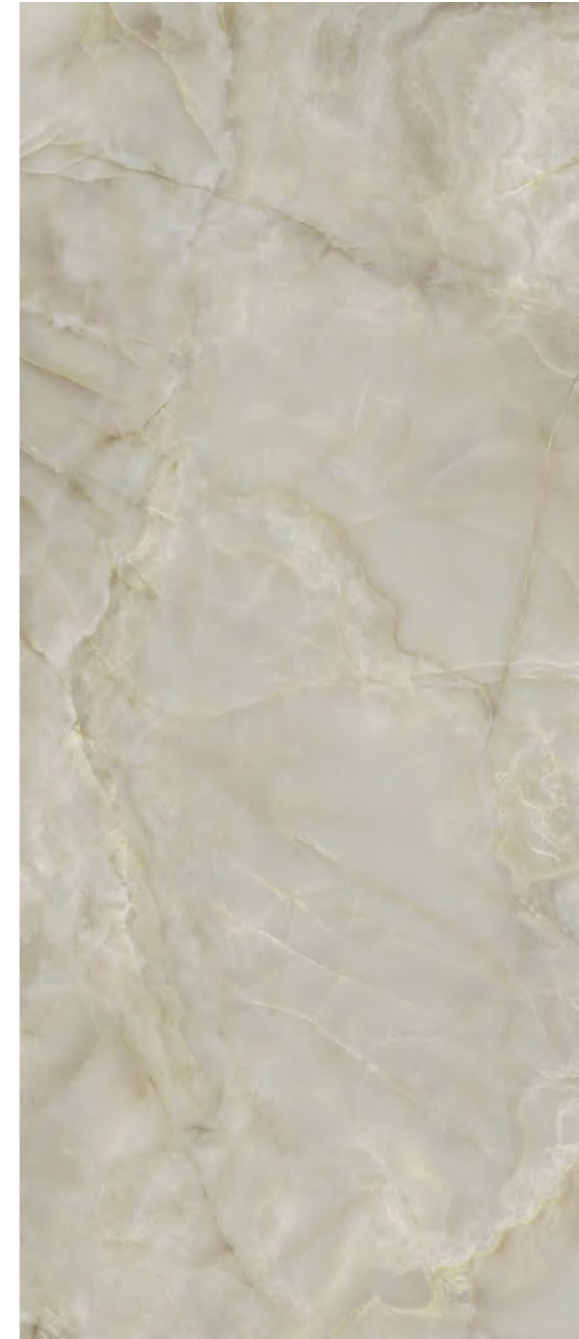

120x280
05457 | Majestic Onyx Smoky Grey Lev/Ret



120x120
05453 | Majestic Onyx Smoky Grey Lev/Ret

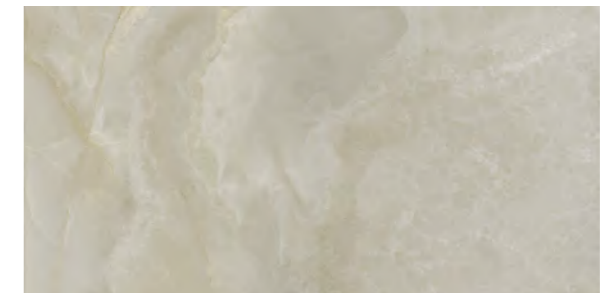

60x120
05448A | Majestic Onyx Smoky Grey Lev/Ret

Majestic Onyx

Iron Grey

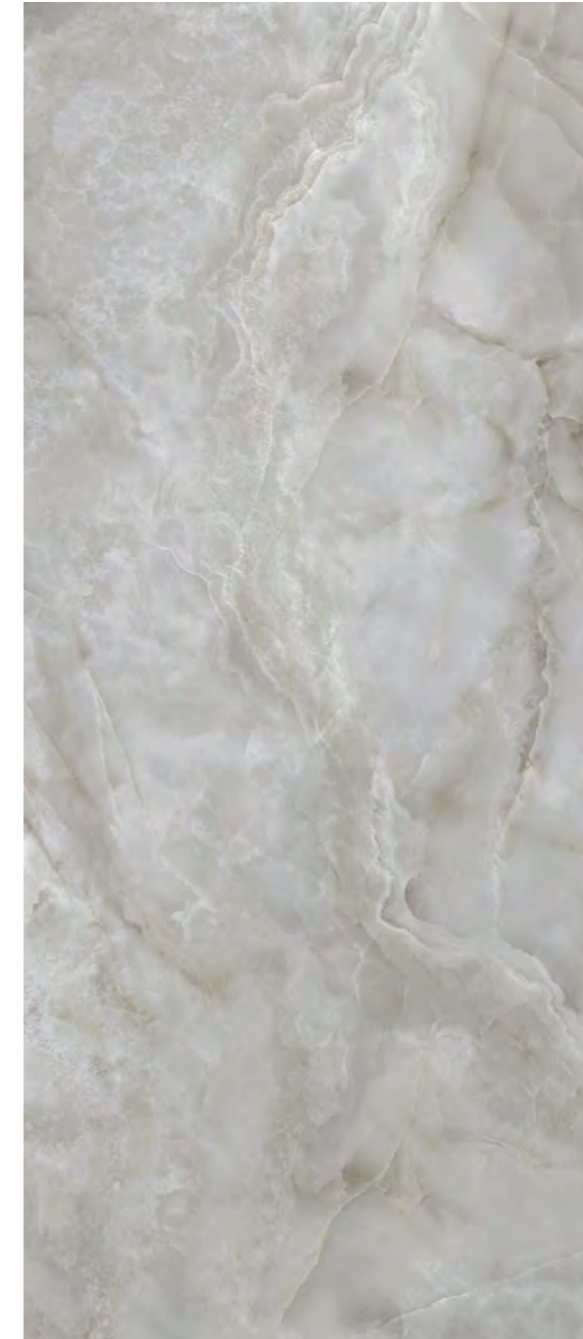

120x280
05537 | Majestic Onyx Iron Grey Lev/Ret

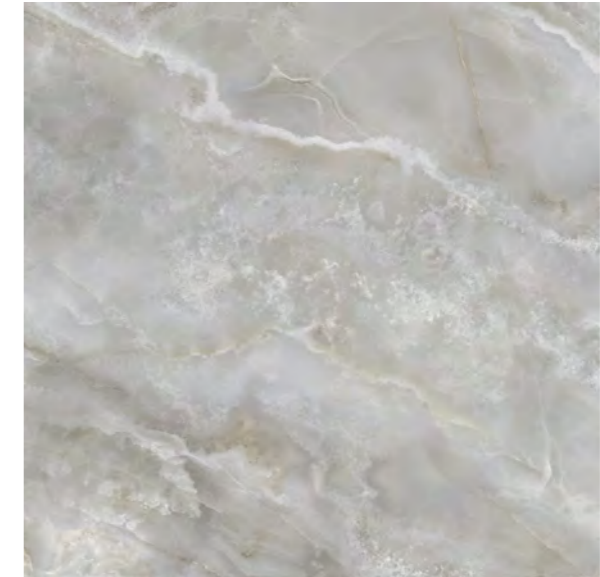

120x120
05536 | Majestic Onyx Iron Grey Lev/Ret

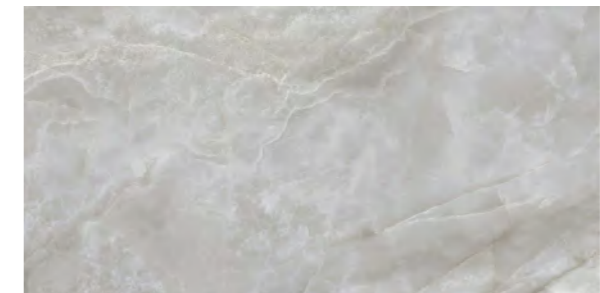

60x120
05535A | Majestic Onyx Iron Grey Lev/Ret

Majestic Onyx

Pale Azure

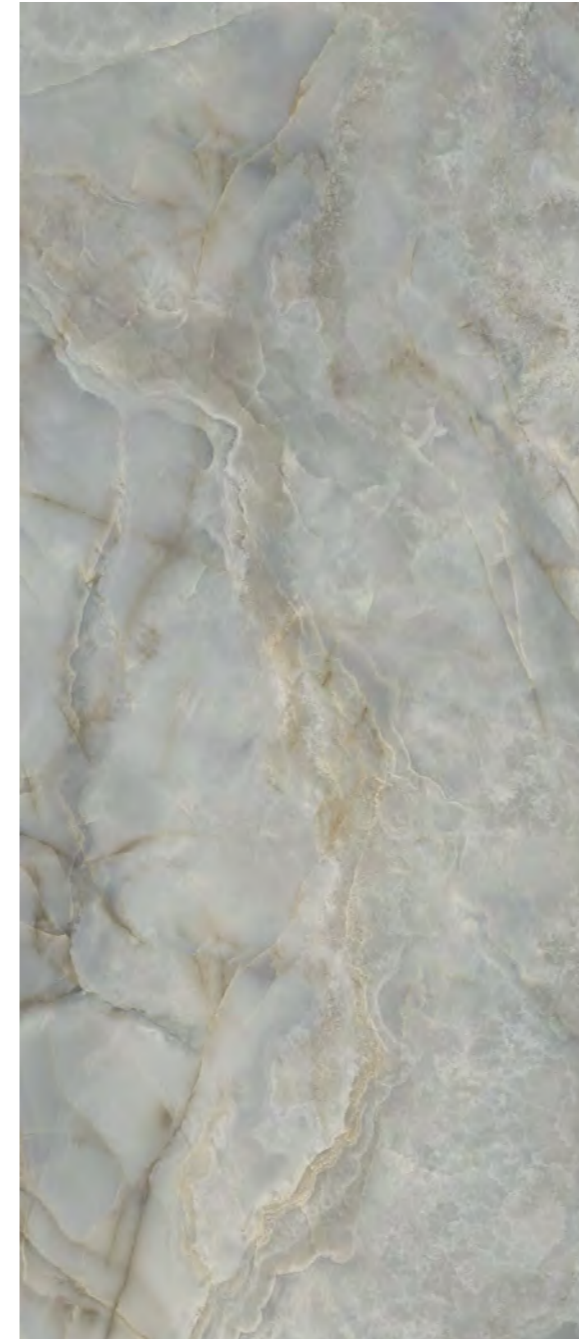

120x280
05459 | Majestic Onyx Pale Azure Lev/Ret

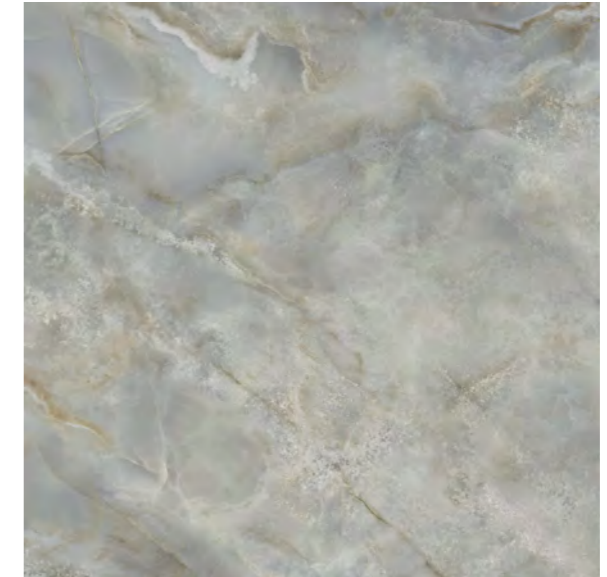

120x120
05455 | Majestic Onyx Pale Azure Lev/Ret



60x120
05451A | Majestic Onyx Pale Azure Lev/Ret

Imballi





Packing
Verpackung
Emballage

Formati Sizes	P	MM							
			Pezzi Scatola Pieces/Box Stck/Karton Carreaux/Boîte	Mq/Scatola Sqmt/Box Qm/Karton M2/Boîte	Kg/Scatola Kgs/Box Kg/Karton Kg/Boîte	Scatole/Paletta Boxes/Pallet Karton/Palette Boîte/Palette	Mq/Paletta Sqmt/Pallet Qm/Pallet M2/Palette	Kg/Paletta Kgs/Pallet Kg/Pallet Kg/Palette	Formato Paletta Size Pallet Format Pallet Dim. Palette
120x280 (48"x110") Lev/Ret	P	6,0	1	3,36	46,50	20	67,20	930	143x294x35
120x120 (48"x48") Lev/Ret	P	8,5	2	2,88	56,00	24	69,12	1344	135x122x68
60x120 (24"x48") Lev/Ret	P	8,5	2	1,44	29,00	44	63,36	1276	122x100x76
Pezzi Speciali / Special Pieces									
33x120 (13"x48") Gradino Costa Retta Lev/Ret	P	8,5	2	0,792	16,00	20	-	-	-
4,5x120 (1 1/4"x48") Battiscopa Lev/Ret	P	8,5	6	0,324	6,10	48	-	-	-

Riepilogo Gamma

Collection
Serie
Gamme

[PDF Merchandising](#)

	Lev/Ret	Formati Sizes					V1
		120x280 48"x110"	120x120 48"x48"	60x120 24"x48"	Pezzi Speciali Special Pieces Gradino Costa Retta 33x120 - 13"x48"	Battiscopa 4,5x120 - 1 1/4"x48"	
	Lev/Ret	05456	05452	05447A	05465	05461	V1
	Lev/Ret	05458	05454	05449A	05467	05463	V1
	Lev/Ret	05457	05453	05448A	05466	05462	V1
	Lev/Ret	05537	05536	05535A	05539	05538	V1
	Lev/Ret	05459	05455	05451A	05468	05464	V1

Majestic Pure Selection

Il fascino e l'eleganza del candore marmoreo italiano rivivono sulle superfici ceramiche di Majestic Pure Selection. La speciale selezione di pregiati marmi Majestic in cui tutta la purezza del bianco viene esaltata dalle quattro trame nobili delle venature italiane più belle e ricercate, come Calacatta, Statuario, Arabescato e Dolomiti.

The allure and elegance of Italian white marble is reproduced on the ceramic surfaces of Majestic Pure Selection. The special selection of fine Majestic marbles in which all the purity of white is enhanced by the four elegant patterns of the most beautiful and sought-after Italian veining, Calacatta, Statuario, Arabescato and Dolomiti.

Der Charme und die Eleganz des reinweißen italienischen Marmors erwecken sich auf den Keramikoberflächen von Majestic Pure Selection. Die Reinheit der Weißsteine wird durch edle Zeichnung der vier schönsten und begehrtesten italienischen Marmore wie Calacatta, Statuario, Arabescato und Dolomiti betont.

Le charme et l'élégance de la blancheur éblouissante du marbre italien reprennent vie sur les surfaces céramiques de Majestic Pure Selection. Dans cette sélection spéciale de marbres précieux Majestic, toute la pureté du blanc est exaltée par les quatre lacs de nobles veinages italiens parmi les plus beaux et les plus recherchés : Calacatta, Statuario, Arabescato et Dolomiti.

4

Colori
Colours
Farben
Couleurs

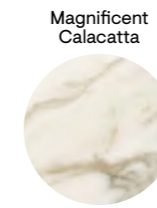
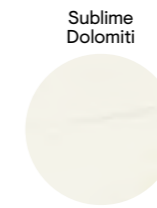

4

Formati
Sizes
Formate
Formats

120×280
48"×110"



120×120
48"×48"



60×120
24"×48"



60×60
24"×24"



2

Superfici
Surfaces
Oberflächen
Surfaces

Naturale Levigato

i

Effetto Marmo
Marble Look
Marmoroptik
Effet Marbre

Rivestimento
Wall Tiles
Wandfliesen
Revêtement

Pavimento
Floor Tiles
Bodenfliesen
Sol

Gres fine porcellanato
Fine porcelain stoneware
Feinsteinzeug
Grès cérame fin

Tecnologia digitale
Digital technology
Digital technologie
Technologie numérique



WATCH THE VIDEO

Majestic Pure Selection

Superb Statuario

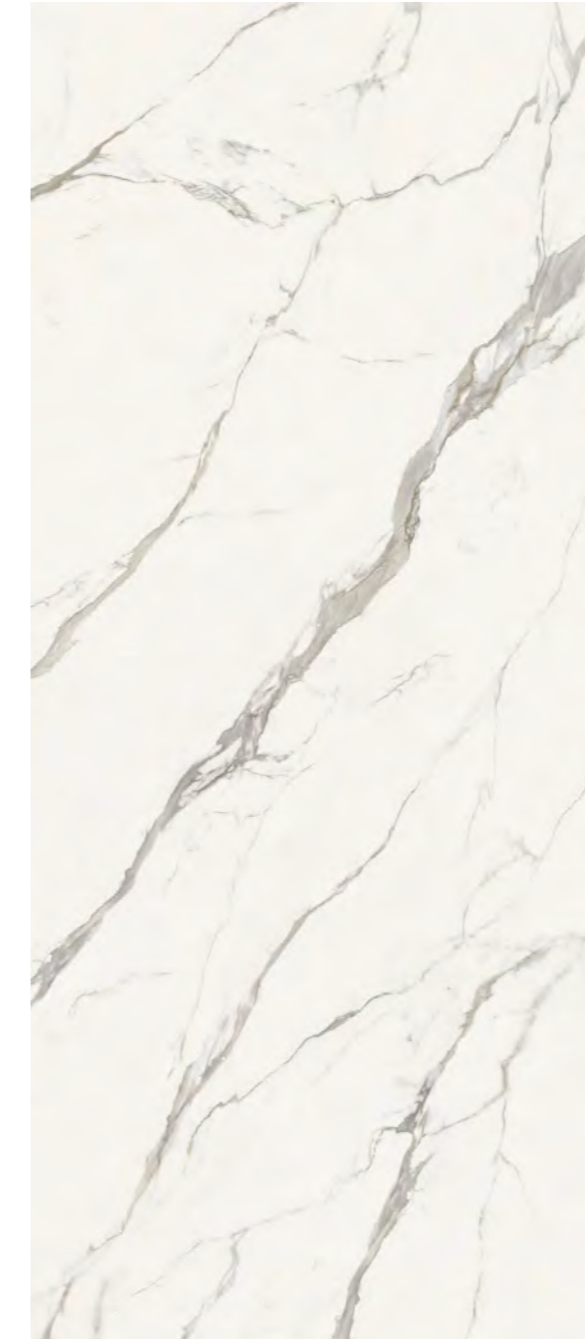

120x280
05473 | Superb Statuario Lev/Ret

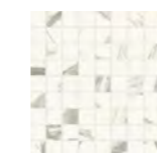

30x30
03926 | Mosaico Superb Statuario Nat/Ret
03931 | Mosaico Superb Statuario Lev/Ret

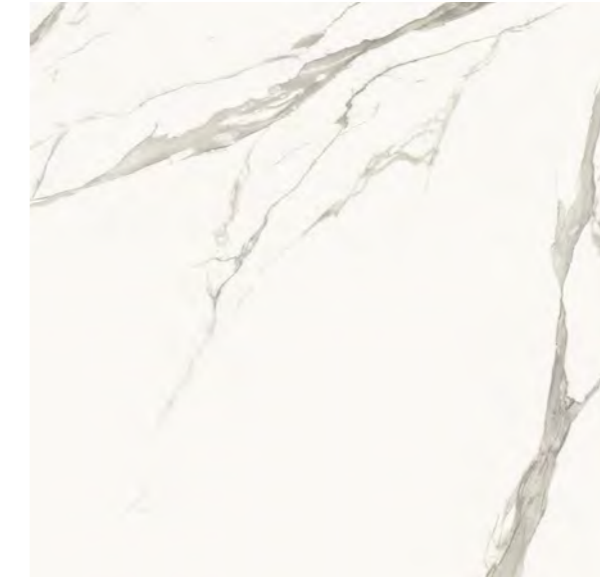

120x120
03921B | Superb Statuario Lev/Ret



60x120
03901B | Superb Statuario Nat/Ret
03905B | Superb Statuario Lev/Ret

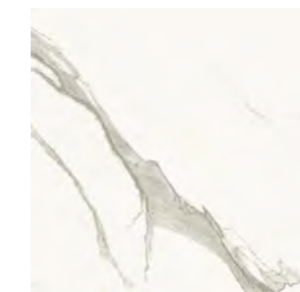

60x60
03912B | Superb Statuario Nat/Ret
03916B | Superb Statuario Lev/Ret



60x120
03909B | Foliage Nat/Ret
(mix 6 graphics)



60x120
03908B | Grove Lev/Ret
(mix 6 graphics)

Majestic Pure Selection

Glorious Arabescato

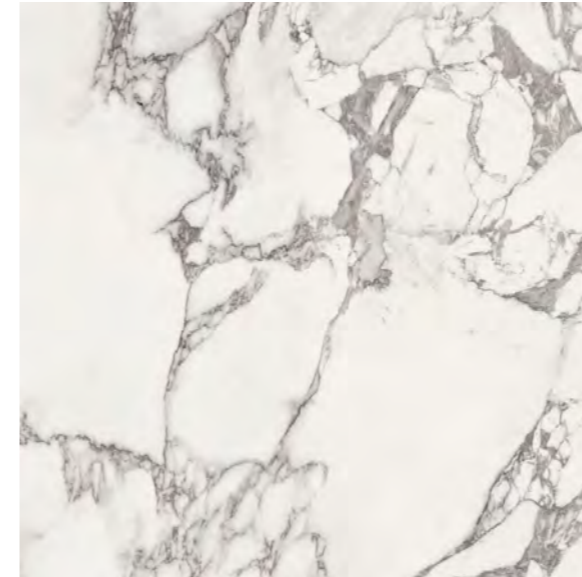

120x120
03922B | Glorious Arabescato Lev/Ret



60x120
03908B | Grove Lev/Ret
(mix 6 graphics)



60x120
03909B | Foliage Nat/Ret
(mix 6 graphics)



60x120
03902B | Glorious Arabescato Nat/Ret
03906B | Glorious Arabescato Lev/Ret



30x30
03927 | Mosaico Glorious Arabescato Nat/Ret
03932 | Mosaico Glorious Arabescato Lev/Ret

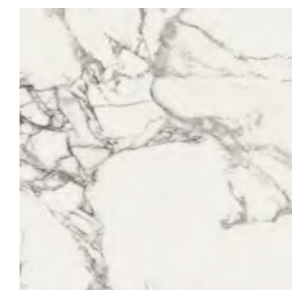

60x60
03913B | Glorious Arabescato Nat/Ret
03917B | Glorious Arabescato Lev/Ret

Majestic Pure Selection

Sublime Dolomiti

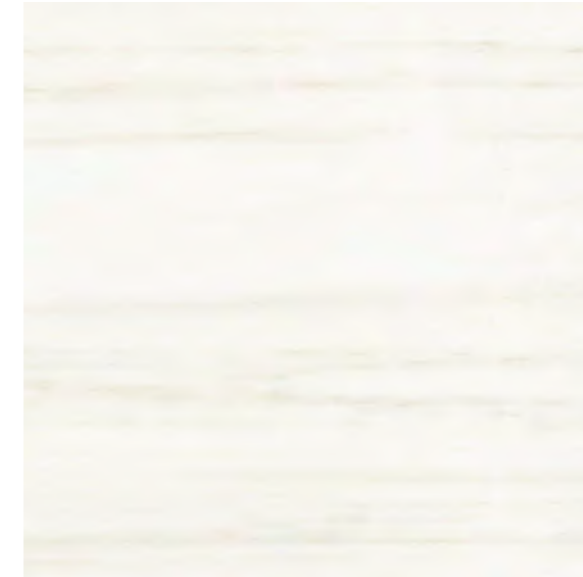

120x120
03923B | Sublime Dolomiti Lev/Ret



60x120
03908B | Grove Lev/Ret
(mix 6 graphics)



60x120
03909B | Foliage Nat/Ret
(mix 6 graphics)



60x120
03903B | Sublime Dolomiti Nat/Ret
03907B | Sublime Dolomiti Lev/Ret

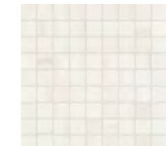

30x30
03928 | Mosaico Sublime Dolomiti Nat/Ret
03933 | Mosaico Sublime Dolomiti Lev/Ret



60x60
03914B | Sublime Dolomiti Nat/Ret
03918B | Sublime Dolomiti Lev/Ret

Majestic Pure Selection

Magnificent Calacatta

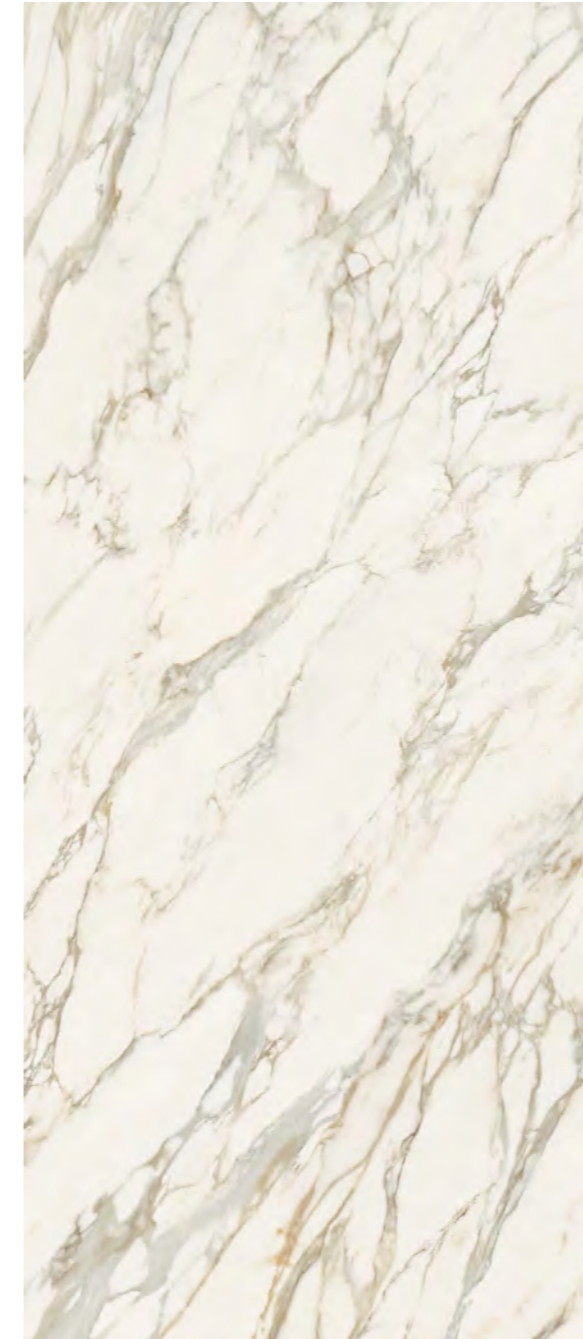

120x280
05472 | Magnificent Calacatta Lev/Ret



120x120
03919B | Magnificent Calacatta Lev/Ret



60x120
03909B | Foliage Nat/Ret
(mix 6 graphics)

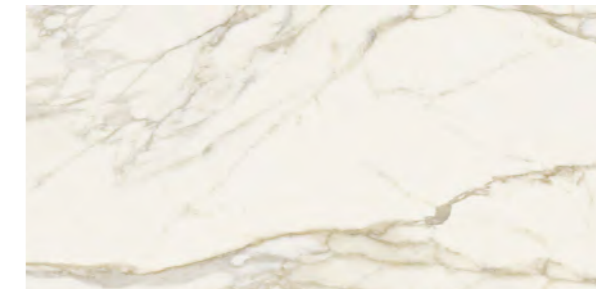

60x120
03899B | Magnificent Calacatta Nat/Ret
03904B | Magnificent Calacatta Lev/Ret



60x120
03908B | Grove Lev/Ret
(mix 6 graphics)

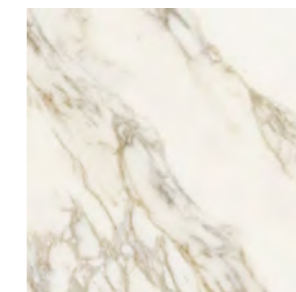







60x60
03911B | Magnificent Calacatta Nat/Ret
03915B | Magnificent Calacatta Lev/Ret



30x30
03925 | Mosaico Magnificent Calacatta Nat/Ret
03929 | Mosaico Magnificent Calacatta Lev/Ret

Imballi



Packing
Verpackung
Emballage

Formati Sizes	MM	 Pezzi Scatola Pieces/Box Stck/Karton Carreaux/Boîte	 Mq/Scatola Sqmt/Box Qm/Karton M2/Boîte	 Kg/Scatola Kgs/Box Kg/Karton Kg/Boîte	 Scatole/Paletta Boxes/Pallet Karton/Palette Boîte/Palette	 Mq/Paletta Sqmt/Pallet Qm/Pallet M2/Palette	 Kg/Paletta Kgs/Pallet Kg/Pallet Kg/Palette	 Formato Paletta Size Pallet Format Pallet Dim. Palette	
120*280 (48"*110") Lev/Ret	P	6,0	1	3,36	46,50	20	67,20	930	143x294x35
120*120 (48"*48") Lev/Ret	P	8,5	2	2,88	55,00	24	69,12	1320	135x122x68
60*120 (24"*48") Nat/Ret - Lev/Ret	P	8,5	2	1,44	28,00	44	63,36	1232	122x100x76
60*60 (24"*24") Nat/Ret	P	8,5	4	1,44	26,00	40	57,6	1040	122x82x75
60*60 (24"*24") Lev/Ret	P	8,5	4	1,44	27,00	40	57,6	1080	122x82x75
60*120 (24"*48") Grove Lev/Ret	P	8,5	2	1,44	29,00	44	63,36	1276	122x100x76
60*120 (24"*48") Foliage Nat/Ret	P	8,5	2	1,44	28,00	44	63,36	1232	122x100x76
30*30 (12"*12") Mosaico Nat/Ret	P	8,5	5	0,45	8,00	60	-	-	-
30*30 (12"*12") Mosaico Lev/Ret	P	8,5	5	0,45	8,00	60	-	-	-
Pezzi Speciali / Special Pieces									
33*120 (13"*48") Gradino Costa Retta Nat/Ret - Lev/Ret	P	8,5	2	0,79	18,50	20	-	-	-
4,5*60 (1 1/2"*24") Battiscopa Nat/Ret - Lev/Ret	P	8,5	14	0,380	8,00	80	-	-	-

Riepilogo Gamma

Collection
Serie
Gamme

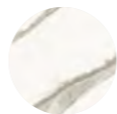
[PDF Merchandising](#)

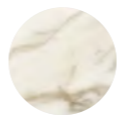
Formati Sizes	120*280 48"*110"			120*120 48"*48"			60*120 24"*48"			60*60 24"*24"			EN 16165C EN 16165A CDOF			Grove 60*120 24"*48"		Foliage 60*120 24"*48"		Mosaico 30*30 12"*12"		Pezzi Speciali Special Pieces	
	MM	MM	MM	MM	MM	MM	MM	MM	MM	MM	MM	MM	MM	MM	MM	MM	MM	MM	MM	MM	MM	MM	
 Superb Statuario	Nat/Ret																						
	Lev/Ret	05473	03921B	03905B	03916B																		
 Glorious Arabescato	Nat/Ret																						
	Lev/Ret		03922B	03906B	03917B																		
 Sublime Dolomiti	Nat/Ret																						
	Lev/Ret		03923B	03907B	03918B																		
 Magnificent Calacatta	Nat/Ret																						
	Lev/Ret	05472	03919B	03904B	03915B																		

Majestic

La ricerca stilistica della collezione Majestic esce volutamente dagli schemi classici di utilizzo delle superfici effetto marmo, per vestire spazi residenziali e commerciali con uno stile eclettico e lussuoso.

The stylistic research of the Majestic collection deliberately goes beyond the classic patterns of use of marble-effect surfaces, to dress residential and commercial spaces with an eclectic and luxurious style.

Die stilistischen Recherchen der Kollektion Majestic gehen mit Absicht über die herkömmlichen Verwendungsmöglichkeiten der Oberflächen mit Marmoroptik hinaus, um Wohn- und Gewerbebereiche in eklektischem, luxuriösem Stil zu verkleiden.

La recherche stylistique de la collection Majestic sort volontairement des sentiers battus de l'utilisation du marbre en céramique, pour revêtir des surfaces résidentielles et commerciales avec un style éclectique et luxueux.

7

Colori
Colours
Farben
Couleurs



4

Formati
Sizes
Formate
Formats

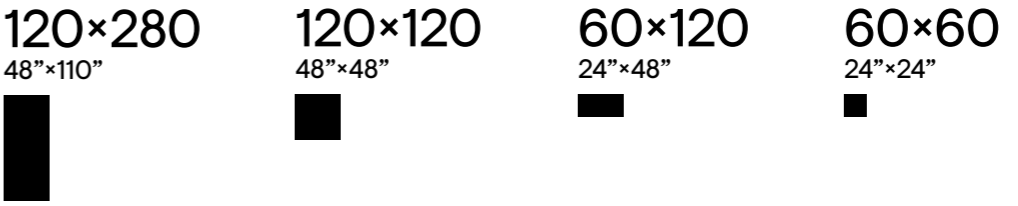

2

Superfici
Surfaces
Oberflächen
Surfaces

Naturale Levigato

i

Effetto Marmo Marble Look Marmoroptik Effet Marbre	Rivestimento Wall Tiles Wandfliesen Revêtement	Pavimento Floor Tiles Bodenfliesen Sol	Gres fine porcellanato Fine porcelain stoneware Feinsteinzeug Grès cérame fin	Tecnologia digitale Digital technology Digital Technologie Technologie numérique
---	---	---	--	---

Ripresa grafica tra le diverse lastre rettificate contenuta entro le tolleranze previste dalla norma. Per un corretto allineamento si consiglia di utilizzare una fuga di 2 mm.
Graphic representation between the rectified tiles is contained within the tolerances provided by the standard. For a correct alignment it is recommended to use a 2 mm joint.
Grafische Darstellung zwischen den verschiedenen rektifizierten Platten innerhalb der in der Norm vorgesehenen Toleranzen. Für eine korrekte Anpassung wird eine Fuge von 2mm empfohlen.
Reproduction graphique entre les différents carreaux rectifiés dans les limites des tolérances prévues par la norme. Pour un alignement correct, il est recommandé d'utiliser joints de 2 mm.

Majestic

Queen's Tiara

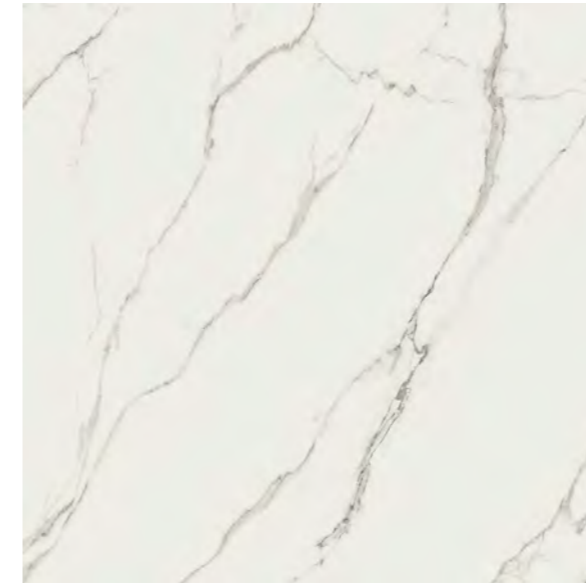

120x120
05304A | Queen's Tiara Lev/Ret



60x120
***02627A** | Majestic Jungle Cold Lev/Ret
(Mix 2 Different Decors)

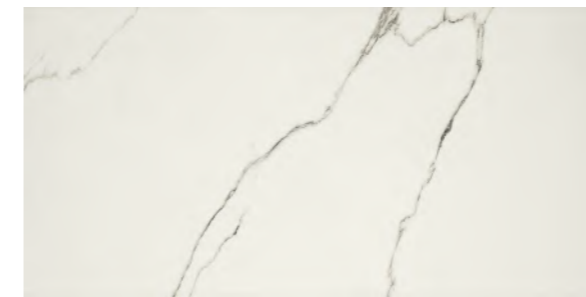

60x120
02656B | Queen's Tiara Nat/Ret
02651B | Queen's Tiara Lev/Ret



60x120
02599B | Majestic Mix Art Lev/Ret
(Mix 2 Different Decors)

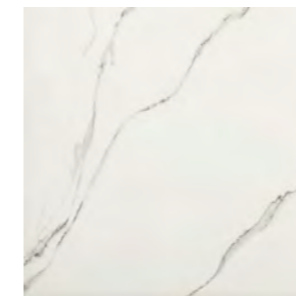

60x60
02655B | Queen's Tiara Nat/Ret
02652B | Queen's Tiara Lev/Ret



34x36
02660 | Hexagon
Queen's Tiara Lev

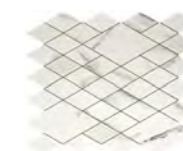

31x35
02661 | Majestic Net
Queen's Tiara Lev

*Decori realizzati con smalti e metalli preziosi. Vedere nota a pag. 382-383
Decors made with glazes and precious metals. See note on pages 382-383
Dekore aus Glasuren und Edelmetallen. Siehe Hinweis auf Seiten 382-383
Décors réalisés avec des émaux et des métaux précieux. Voir note aux pages 382-383

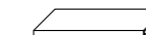

Majestic

Imperial Pearl



60x120
02584B | Imperial Pearl Nat/Ret
02578B | Imperial Pearl Lev/Ret



60x60
02572B | Imperial Pearl Nat/Ret
02565B | Imperial Pearl Lev/Ret



34x36
02617 | Hexagon
Imperial Pearl Lev

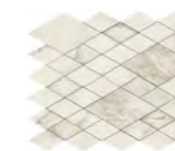

31x35
02624 | Majestic Net
Imperial Pearl Lev



28x32,5
02633 | Majestic Arrows
Warm Lev



60x120
*02626A | Majestic Jungle Warm Lev/Ret
(Mix 2 Different Decors)



60x120
02599B | Majestic Mix Art Lev/Ret
(Mix 2 Different Decors)



* Decori realizzati con smalti e metalli preziosi. Vedere nota a pag. 382-383
Decors made with glazes and precious metals. See note on pages 382-383
Dekore aus Glasuren und Edelmetallen. Siehe Hinweis auf Seiten 382-383
Décors réalisés avec des émaux et des métaux précieux. Voir note aux pages 382-383

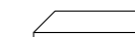
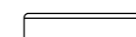

Majestic

Precious Gem



60x120
02665B | Precious Gem Nat/Ret
02662B | Precious Gem Lev/Ret

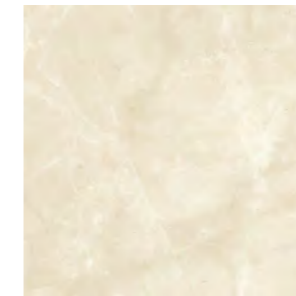

60x60
02666B | Precious Gem Nat/Ret
02663B | Precious Gem Lev/Ret



34x36
02676 | Hexagon
Precious Gem Lev



31x35
02677 | Majestic Net
Precious Gem Lev



60x120
***02626A** | Majestic Jungle Warm Lev/Ret
(Mix 2 Different Decors)



60x120
02599B | Majestic Mix Art Lev/Ret
(Mix 2 Different Decors)

*Decori realizzati con smalti e metalli preziosi. Vedere nota a pag. 382-383
Decors made with glazes and precious metals. See note on pages 382-383
Dekore aus Glasuren und Edelmetallen. Siehe Hinweis auf Seiten 382-383
Décors réalisés avec des émaux et des métaux précieux. Voir note aux pages 382-383

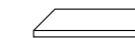
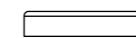

Majestic

Supreme Grey



120x120
02588B | Supreme Grey Lev/Ret



60x120
02585B | Supreme Grey Nat/Ret
02579B | Supreme Grey Lev/Ret



60x60
02573B | Supreme Grey Nat/Ret
02566B | Supreme Grey Lev/Ret



60x120
***02626A** | Majestic Jungle Warm Lev/Ret
(Mix 2 Different Decors)



60x120
02599B | Majestic Mix Art Lev/Ret
(Mix 2 Different Decors)



30x30
02647 | Cube
Supreme Grey Nat



34x36
02618 | Hexagon
Supreme Grey Lev

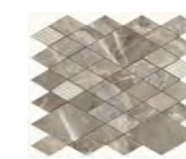

31x35
02625 | Majestic Net
Supreme Grey Lev



28x32,5
02633 | Majestic Arrows
Warm Lev

*Decori realizzati con smalti e metalli preziosi. Vedere nota a pag. 382-383
Decors made with glazes and precious metals. See note on pages 382-383
Dekore aus Glasuren und Edelmetallen. Siehe Hinweis auf Seiten 382-383
Décors réalisés avec des émaux et des métaux précieux. Voir note aux pages 382-383

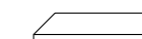
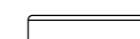

Majestic

Eccentric



120x280
05476 | Eccentric Lev/Ret

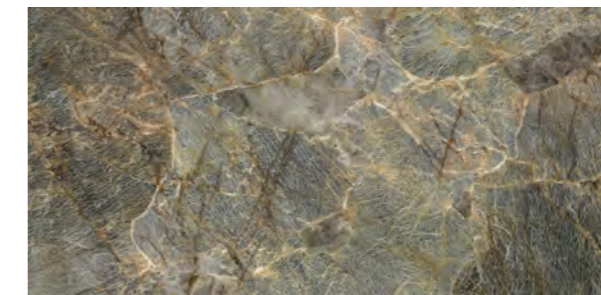

60x120
03349B | Eccentric Lev/Ret

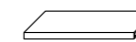

Majestic

Lime Black

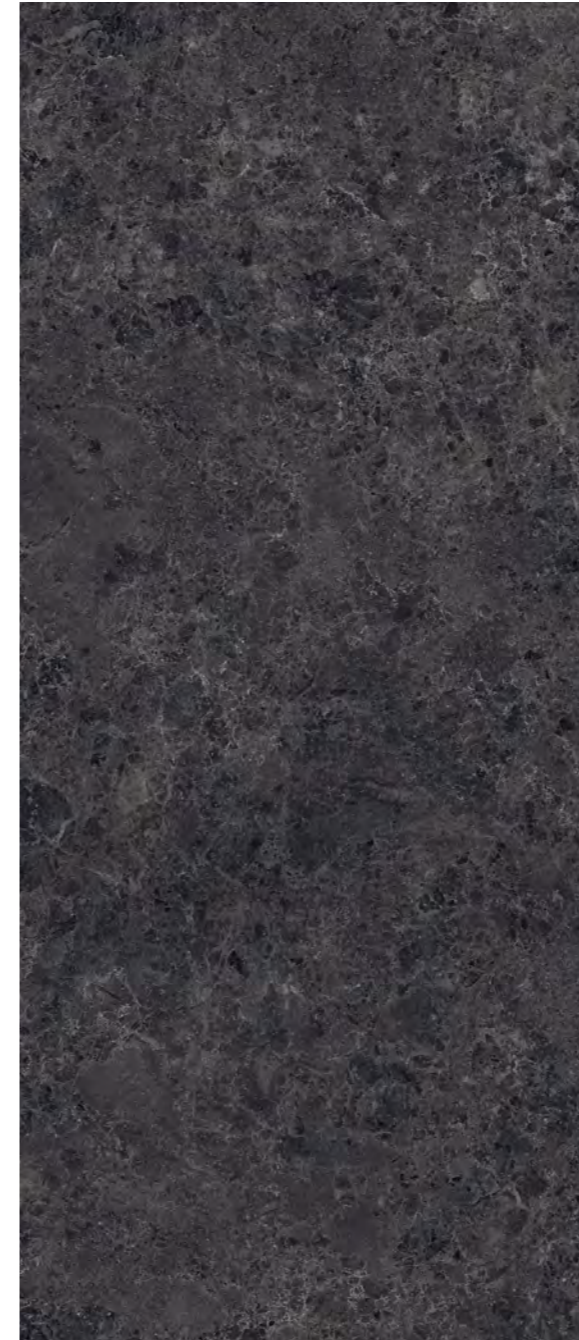

120x280
05488 | Lime Black Lev/Ret

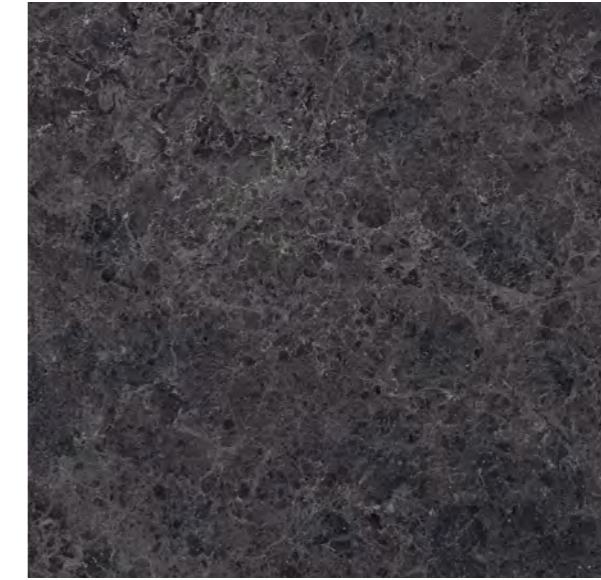

120x120
05594 | Lime Black Lev/Ret

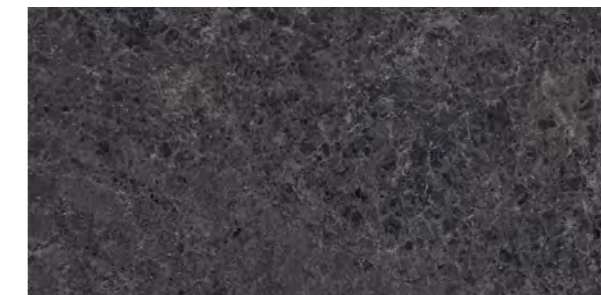

60x120
05595A | Lime Black Lev/Ret

Royal Nero



60x120
02580B | Royal Nero Nat/Ret

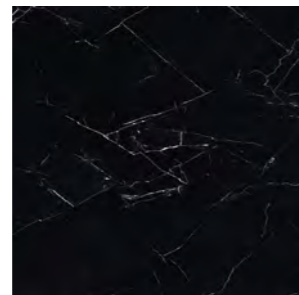

60x60
02567B | Royal Nero Nat/Ret



7,5x30
02643 | Brick Royal
Nero Nat/Ret



30x30
02646 | Cube Royal Nero Nat

Imballi

Packing
Verpackung
Emballage

Formati Sizes	P	I MM							
			Pezzi Scatola Pieces/Box Stck/Karton Carreaux/Boîte	Mq/Scatola Sqmt/Box Qm/Karton M2/Boîte	Kg/Scatola Kgs/Box Kg/Karton Kg/Boîte	Scatole/Paletta Boxes/Pallet Karton/Palette Boîte/Palette	Mq/Paletta Sqmt/Pallet Qm/Pallet M2/Palette	Kg/Paletta Kgs/Pallet Kg/Pallet Kg/Palette	Formato Paletta Size Pallet Format Pallet Dim. Palette
120x280 (48"x110") Lev/Ret	P	6,0	1	3,36	46,50	20	67,20	930	143x294x35
120x120 (48"x48") Lev/Ret	P	8,5	2	2,88	55,00	24	69,12	1320	135x122x68
60x120 (24"x48") Nat/Ret - Lev/Ret	P	8,5	2	1,44	28,00	44	63,36	1232	122x100x76
60x60 (24"x24") Nat/Ret - Lev/Ret	P	8,5	4	1,44	26,00	40	57,60	1040	122x82x75
60x120 (24"x48") Mix Art Lev/Ret	P	8,5	2	1,44	28,00	44	63,36	1232	122x100x76
60x120 (24"x48") Jungle Lev/Ret	P	8,5	2	1,44	32,00	15	21,60	480	122x82x75
7,5x30 (3"x12") Brick Nat/Ret	P	8,5	22	0,50	10,50	96	-	-	-
34x36 (13¼"x14¼") Hexagon Lev/Ret	P	8,5	6	0,73	15,30	40	-	-	-
28x32,5 (11"x12¼") Arrows Lev/Ret	P	8,5	6	0,55	11,50	54	-	-	-
31x35 (11¼"x13¼") Net Lev/Ret	P	8,5	6	0,65	13,56	40	-	-	-
30x30 (12"x12") Cube Nat/Ret	P	8,5	5	0,45	8,00	54	-	-	-
Pezzi Speciali / Special Pieces									
33x120 (13"x48") Gradino Costa Retta Nat/Ret - Lev/Ret	P	8,5	2	0,79	18,50	20	-	-	-
8x60 (3¼"x24") Battiscopa Nat/Ret - Lev/Ret	P	8,5	10	0,480	11,00	72	-	-	-
6,5x120 (1½"x48") Battiscopa Nat/Ret - Lev/Ret	P	8,5	8	0,620	14,00	48	-	-	-

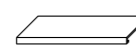
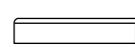

Riepilogo Gamma

Collection
Serie
Gamme

Formati Sizes										
	120x280 48"x110"	120x120 48"x48"	60x120 24"x48"	60x60 24"x24"			EN 16165C	EN 16165A	Mix Art 60x120 24"x48"	Jungle 60x120 24"x48"
	± 6,0	± 8,5	± 8,5	± 8,5	PEI				± 8,5	± 8,5
Queen's Tiara	Nat/Ret		02656B	02655B	V4	V	R9	A		
	Lev/Ret	05304A	02651B	02652B						
Imperial Pearl	Nat/Ret		02584B	02572B	V4	V	R9	A		
	Lev/Ret		02578B	02565B						
Precious Gem	Nat/Ret		02665B	02666B	V4	V	R9	A		
	Lev/Ret		02662B	02663B						
Supreme Grey	Nat/Ret		02585B	02573B	V4	V	R9	A		
	Lev/Ret	02588B	02579B	02566B						
Eccentric	Lev/Ret	05476	03349B		V4	V				
Lime Black	Lev/Ret	05488	05594	05595A	V4	IV			02599B	02626A 02627A
Royal Nero	Nat/Ret			02580B	02567B	V4	IV	R9	A	

Riepilogo Gamma

Collection
Serie
Gamme

Formati Sizes						Pezzi Speciali Special Pieces					
	Brick 7,5x30 3"x12"	Hexagon 34x36 13 ^{3/8} "x14 ^{1/8} "	Arrows 28x32,5 11"x12 ^{3/4} "	Net 31x35 12 ^{1/4} "x13 ^{3/4} "	Cube 30x30 12"x12"	Gradino Costa Retta 33x120 13"x48"	Battiscopa 8x60 3"x24"	Battiscopa 6,5x120 2 ^{1/2} "x48"			
	± 8,5	± 8,5	± 8,5	± 8,5	± 8,5	± 8,5	± 8,5	± 8,5			
Queen's Tiara	Nat/Ret							02764A	02716	02732A	V4
	Lev/Ret		02660		02661			03739A	02708	02724A	
Imperial Pearl	Nat/Ret							02762A	02714	02730A	V4
	Lev/Ret		02617	02633	02624			02754A	02706	02722A	
Precious Gem	Nat/Ret							02765A	02717	02733A	V4
	Lev/Ret		02676		02677			03741A	02709	02725A	
Supreme Grey	Nat/Ret	02644					02647	02763A	02715	02731A	V4
	Lev/Ret		02618	02633	02625			03738A	02707	02723A	
Eccentric	Lev/Ret							03384A			V4
Lime Black	Lev/Ret							05635		05636	V4
Royal Nero	Nat/Ret	02643					02646	02758A	02710	02726A	V4

TECHNICAL DATA

Dati Tecnici / Technische Daten / Fiches Techniques

- 370 PEZZI SPECIALI
Special pieces / Formstücke / Pièces spéciales
- 375 GUIDA ALLA LETTURA
Reading Guide / Leseanleitung / Guide a la lecture
- 376 NOTE TECNICHE 120x120 / 120x280
120x120 - 120x280 Technical Notes / Technische Hinweise 120x120 - 120x280 /
Notes Techniques 120x120 - 120x280
- 378 STRUMENTI DI MOVIMENTAZIONE
Handling toolse / Handhabungsgeräte / Équipements de manutention
- 380 IMBALLAGGI IN CASSA DI LEGNO
Packaging in wooden crate 120x280 / Verpackung in Holzkiste 120x280 /
Conditionnement en caisse bois 120x280
- 381 IMBALLAGGI IN CAVALLETTO
Packaging on a frame 120x280 - 120x120 / Verpackung auf Transportgestell 120x280 - 120x120 /
Emballage en chevalet 120x280 - 120x120
- 382 NORME DI POSA
Installation instructions / Hinweise Für Die Verlegung / Pose
- 384 NORME DI MANUTENZIONE
Cleaning / Hinweise Zur Pflege / Règles D'entretien
- 386 GRES FINE PORCELLANATO
Porcelain Stoneware / Feinsteinzeug / Grès Cérame
- 387 PASTA BIANCA
White Body / Weißscherbig / Pâte Blanche
- 388 CERTIFICAZIONI
Certifications / Zertifizierungen / Certifications
- 392 CONDIZIONI DI VENDITA
General Terms and Conditions of Sale / Allgemeine Verkaufsbedingungen /
Conditions Generales de Vente

Pezzi Speciali

Special pieces
Formstücke
Pièces spéciales

Battiscopa

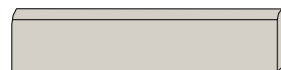

4,5x60
Artdesia 2.0, Cement Vibes, Evoluta, Glitch, Homey, Ibla, Journey, Limestone, Majestic Pure Selection, Moon, Materia, Stone Revolution, Suprema



8x60
Bits&Pieces, Castlestone, Concrete, Geostone, Majestic, More, Purestone, Uniquestone, Venetian Marble

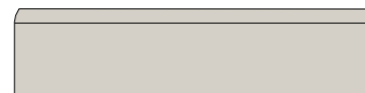

8x80
Concrete, Uniquestone



6,5x120
Bits&Pieces, Cottage, Fleur de Bois, Majestic, Uniquestone



4,5x120
Majestic Onyx, Solorovere, Solonoce, Soul

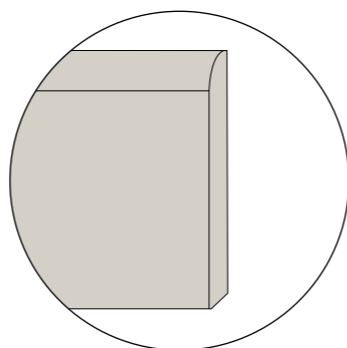

Step

(becco civetta e fresature tecniche - bullnose edge with grooves)



30x60
Artdesia 2.0, Bits&Pieces, Castlestone, Concrete, Moon, More, Purestone, Venetian Marble

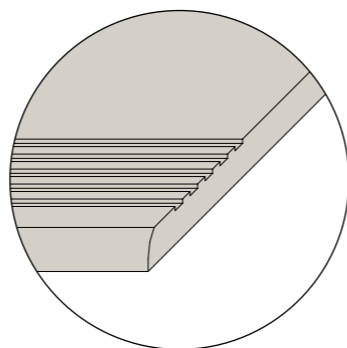

Step

(becco civetta digitale a caldo - hot digital bullnose edge)



20x120
Fleur De Bois

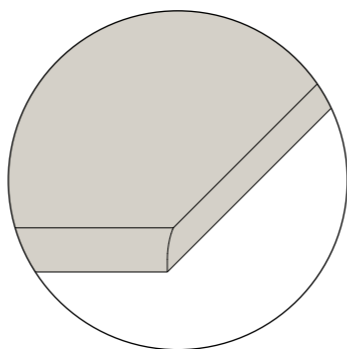

Gradino Costa Retta

(ottenuto per taglio e incollaggio - obtained by cutting and gluing)

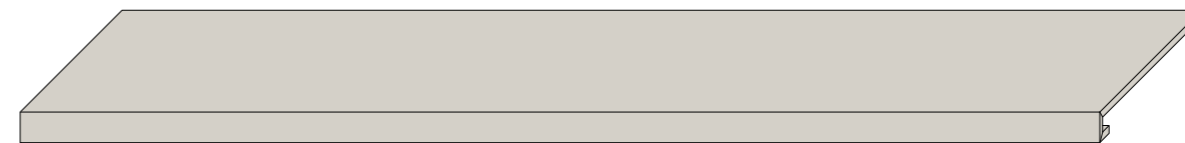

33x120
Cement Vibes, Evoluta, Glitch, Homey, Ibla, Journey, Limestone, Majestic, Majestic Onyx, Majestic Pure Selection, Materia, Stone Revolution, Uniquestone

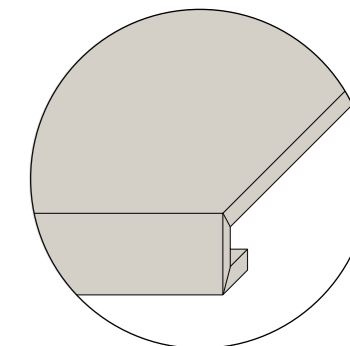

Pezzi Speciali 20mm

20mm special pieces
Formstücke 20mm
Pièces spéciales 20mm

Elemento L

(ottenuto per taglio e incollaggio - obtained by cutting and gluing)



30x60x5 Sp.20mm
Concrete

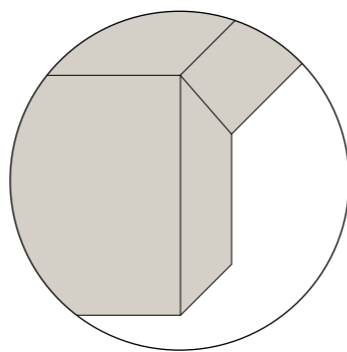

Gradone

(Toro tecnico - full bullnose edge)



30x60 Sp.20mm
Concrete

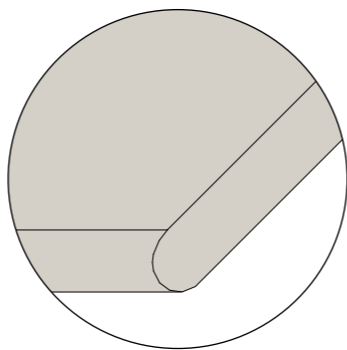

Pezzi Speciali 20mm su Richiesta

20mm special pieces upon request
Formstücke 20mm auf Anfrage
Pièces spéciales 20mm sur demande

Gradone Angolare

(toro tecnico - full bullnose edge)

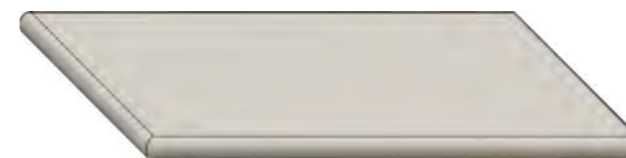

Angolo Sx

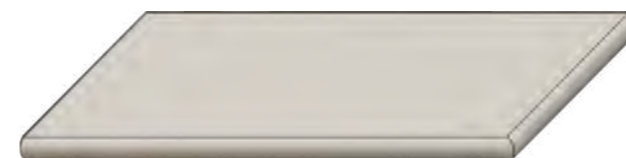

Angolo Dx

30x60 Sp.20mm
Concrete

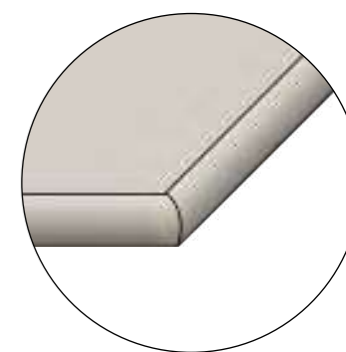

Guida alla Lettura

Reading Guide
Leseanleitung
Guide à la lecture

 Spessore
Thickness
Stärke
Épaisseur

Variazione nelle sfumature di colore
Color shade variations
Variation der Farbnuancen
Variation des nuances de couleur

Certificazioni
Certifications
Prüfzeugnisse
Certifications

P Gres fine porcellanato
Porcelain Stoneware
Feinsteinzeug
Grès Cérame

 V1 Aspetto uniforme
Uniform appearance
Gleichförmiges aussehen
Aspect uniforme



PB Pasta Bianca
White Body
Weißscherbisig
Pâte Blanche

 V2 Variazione leggera
Slight variation
Leichte variation
Légère variation



 V3 Variazione moderata
Moderate variation
Mäßige variation
Variation modeste

Resistenza alla scivolosità
Skid resistance
Rutschfestigkeit
Resistance au glissement

 V4 Variazione casuale
Random variation
Zufällige variation
Variation fortuite

EN 16165C	EN 16165A	DCOF
R11	A+B+C	>0,42

Tutti i formati sono nominali.
Gli spessori riportati in questo catalogo sono nominali e possono variare a seconda dei formati e delle finiture.
I colori e le caratteristiche estetiche dei prodotti sono quanto più possibile vicini a quelli reali, nei limiti consentiti dai processi di stampa.

All sizes are nominal.
The thickness mentioned on this catalogue are nominal and can be different according to the sizes and the finishes.
The colours and appearance features of the products are as close as possible to reality, within the limitation of the printing process.

Die Formate sind Nennwerte.
Die in diesem Katalog angegebenen Fliesenstärke sind nominal und können, je nach Format oder Oberfläche, verschieden sein.
Die Farben und die ästhetischen Eigenschaften der Produkte entsprechen der Wirklichkeit, innerhalb den von dem Druckverfahren erlaubten Grenzen.

Tous les formats sont nominaux.
Les épaisseurs reportées sur ce catalogue sont nominales et peuvent varier suivant les formats et les finitions.
Les couleurs et les caractéristiques esthétiques sont fidèles aux couleurs et caractéristique réelles dans les limites des procédés d'impression.

Все форматы являются номинальными.
Указанная в данном каталоге толщина является номинальной и может изменяться в зависимости от форматов и отделки.
Цвета и эстетические характеристики изделий максимально приближены к реальным, в рамках возможностей типографских процессов.

Note Tecniche 120x120 / 120x280

120x120 / 120x280 Technical Notes

Technische Hinweise 120x120 / 120x280

Notes Techniques 120x120 / 120x280

SUGGERIMENTI DI IMPIEGO

UN FORMATO VERSATILE CHE, GRAZIE ALLE CARATTERISTICHE TECNICHE DI ROBUSTEZZA, RESISTENZA A SBALZI TERMICI E FACILITÀ DI LAVORAZIONE, È IDEALE PER NUMEROSE DESTINAZIONI D'USO. IL GRANDE FORMATO PERMETTE DI RIVESTIRE LE SUPERFICI CON SEMPRE MENO FUGHE CREANDO UNA CONTINUITÀ VISIVA DELLA MATERIA: IL RISULTATO È UNO SPAZIO DOVE ARCHITETTI E INTERIOR DESIGNER POSSONO PROGETTARE SENZA RINUNCIARE ALLA BELLEZZA E QUALITÀ DEI MATERIALI.

POSA / MOVIMENTAZIONE DELLE LASTRE

DURANTE LE VERIFICHE PRELIMINARI SUL CANTIERE È OPPORTUNO ACCERTARE ANCHE LA POSSIBILITÀ DI MOVIMENTARE FACILMENTE LE LASTRE ALL'INTERNO DEI LOCALI DI POSA. TUTTI I FORMATI CHE SUPERANO I 100 CM SIA DI LUNGHEZZA CHE DI LARGHEZZA DEVONO ESSERE MANEGGIATI DA 2 POSATORI. PER UNA CORRETTA GESTIONE DELLE LASTRE, A PARTIRE DALLA FASE DI APERTURA DEGLI IMBALLI, È NECESSARIO AVVALERSI DI DISPOSITIVI IDONEI PER LA MOVIMENTAZIONE. PER LA MOVIMENTAZIONE MANUALE E LA SUCCESSIVA POSA IN OPERA DELLE LASTRE DI GRANDI DIMENSIONI, AL FINE DI GARANTIRE LA SICUREZZA PER GLI OPERATORI E L'INTEGRITÀ DEL MATERIALE, È VIVAMENTE CONSIGLIATO L'UTILIZZO DI BARRE DI MOVIMENTAZIONE CON VENTOSE.

GLI APPOSITI CARRELLI DI MOVIMENTAZIONE SONO IDEALI SUL CANTIERE COME “MAGAZZINO” PER UNA O PIÙ LASTRE, OLTRE CHE PER EFFETTUARE IN TOTALE SICUREZZA L'OPERAZIONE DI SPALMATURA DELL'ADESIVO SUL RETRO DELLA LASTRA.

TAGLIO DELLE LASTRE

È OPPORTUNO EFFETTUARE LE OPERAZIONI DI TAGLIO SU UNA SUPERFICIE PIANA, STABILE E PLANARE. È CONSIGLIATO L'UTILIZZO DI GUIDE DA TAGLIO PROFESSIONALI CON CARRELLO INCISORE. UNA VOLTA RIMOSSA LA LASTRA DALL'IMBALLO E POSIZIONATA SUL PIANO DI LAVORO SEGNARE ALLE DUE ESTREMITÀ LA DIMENSIONE DA ASPORTARE. POSIZIONARE E BLOCCARE LA GUIDA DI TAGLIO, TENENDO CONTO DELLA DISTANZA DEL DISCO DI TAGLIO. INCIDERE LE ESTREMITÀ DELLA LASTRA PER CIRCA 5 CM SPINGENDO IL CARRELLO DI INCISIONE DALL'INTERNO VERSO L'ESTERNO. PROCEDERE POI CON L'INCISIONE DELLA LASTRA AVENDO CURA DI ESERCITARE UNA PRESSIONE ED UN AVANZAMENTO DEL CARRELLO COSTANTI PER TUTTA LA LUNGHEZZA DEL TAGLIO. TRASLARE LA LASTRA IN MODO DA PORTARE LA LINEA DI INCISIONE AL DI FUORI DEL PIANO DI LAVORO DI CIRCA 5/10 CM. RIMUOVERE LA GUIDA DI INCISIONE ED INIZIARE L'OPERAZIONE DI TRONCATURA POSIZIONANDO L'APPOSITA PINZA IN CORRISPONDENZA DELLA LINEA INCISA; ESERCITARE UNA PRESSIONE LEGGERA E PROGRESSIVA VERSO IL BASSO. QUEST'OPERAZIONE RISULTERÀ MOLTO SEMPLICE IN QUANTO I PRODOTTI SONO PRIVI DI TENSIONATURE E PER QUESTO FACILMENTE LAVORABILI. A QUESTO PUNTO SI PUÒ PROCEDERE CON LA FINITURA, CHE DOVRÀ ESSERE EFFETTUATA UTILIZZANDO GLI APPOSITI TAMPONI DIAMANTATI O IN ALTERNATIVA MEDIANTE DISCHI RESINOSI ABRASIVI.

TAGLI A L / SCASSI / FORI RETTANGOLARI

TRACCIARE LA PORZIONE DA ASPORTARE SULLA LASTRA ED ESEGUIRE SUCCESSIVAMENTE, IN CORRISPONDENZA DEL PUNTO DI UNIONE DELLE LINEE, FORI DI DIAMETRO 6/8 CON FORETTI DIAMANTATI A UMIDO. CONGIUNGERE POI I FORI MEDIANTE UNA SMERIGLIATRICE ANGOLARE EQUIPAGGIATA CON DISCO DIAMANTATO (DIAMETRO MAX. 125 MM).

INCOLLAGGIO

È NECESSARIO UTILIZZARE LA TECNICA A DOPPIA SPALMATURA, OVVERO IL COLLANTE DEV'ESSERE APPLICATO SIA SUL FONDO DI POSA CHE SUL RETRO DELLA PIASTRELLA. È CONSIGLIATO UTILIZZARE UN ADESIVO A BASE CEMENTIZIA A LETTO PIENO DI CLASSE C2F S1/S2. BISOGNA ASSICURARSI CHE LA SUPERFICIE DA RIVESTIRE SIA CONSISTENTE, PLANARE, NON UNTA E PRIVA DI POLVERE. ELIMINARE LE POLVERI CHE POTREBBERO TROVARSI A CONTATTO DELLE LASTRE. CON L'UTILIZZO DI UNA SPATOLA A DENTI INCLINATI CON DENTE MINIMO DI 8 MM, STENDERE IL COLLANTE SULLA SUPERFICIE DA RIVESTIRE CON MOVIMENTI LINEARI E MAI CIRCOLARI. SUL RETRO DELLA LASTRA INVECE STENDERE IL COLLANTE UTILIZZANDO UNA SPATOLA DENTATA MAI INFERIORE A 5 MM (TENENDO CONTO CHE LA SOMMA DELLE SPATOLE UTILIZZANTE PER SOTTOFONDO E LASTRA DEV'ESSERE COMPRESA TRA I 13 E 14 MM). PER UNA CORRETTA POSA DI MAXI&THIN È RACCOMANDATO FAR DEFLUIRE, PER VIBRAZIONE, LE BOLLE D'ARIA CHE POSSONO CREARSI FRA LA PIASTRELLA E L'ADESIVO FINO A OTTENERE IL “LETTO PIENO” DI COLLANTE. PER QUESTA FASE È CONSIGLIABILE UTILIZZARE UN BATTITORE MANUALE IN GOMMA OPPURE UTILIZZARE I DISPOSITIVI ELETTRICI BATTI-PIASTRELLE. LO STRATO ADESIVO DEV'ESSERE ALMENO DI 4 MM QUINDI È PREFERIBILE UTILIZZARE DEI DISTANZIALI LIVELLANTI PER EVITARE DELLE INTERRUZIONI NELLA MASSA ADESIVA. IN RELAZIONE ALLA POSIZIONE DEI GIUNTI DI DILATAZIONE, LA FUGA MINIMA CONSIGLIATA È DI 2 MM. NEL CASO DI PAVIMENTI E PARETI A CONTATTO, DA POSARE ENTRAMBI CON LASTRE CERAMICHE, È FONDAMENTALE MANTENERE LA LARGHEZZA MINIMA DI 2 MM PER UN RISULTATO DURATURO NEL TEMPO. È POSSIBILE EVENTUALMENTE REALIZZARE FUGHE INFERIORI A RIVESTIMENTO DOPO OPPORTUNE VERIFICHE TECNICHE DA EFFETTUARSI SUL CANTIERE. È NECESSARIO RIEMPIRE LE FUGHE PER ALMENO I 2/3 DELLO SPESSORE CON L'APPOSITO SIGILLANTE. PRESTARE ATTENZIONE ALL'EVENTUALE PRESENZA DI RESIDUI DI ADESIVO ALL'INTERNO DELLE FUGHE.

376  INDEX

SUGGESTIONS FOR USE

A VERSATILE SIZE WHICH, THANKS TO ITS TECHNICAL FEATURES – STURDINESS, RESISTANCE TO HEAT FLUCTUATIONS AND EASY WORKABILITY – IS IDEAL FOR A WHOLE RANGE OF DIFFERENT USES. THE LARGE SIZE PERMITS COVERING SURFACES WITH INCREASINGLY FEWER JOINTS, THUS CREATING A VISUAL CONTINUITY OF THE MATERIAL: THE RESULT IS A SPACE WHERE ARCHITECTS AND INTERIOR DESIGNERS CAN GET TO WORK WITHOUT GIVING UP THE BEAUTY AND QUALITY OF THE MATERIALS.

INSTALLATION / SHEET HANDLING

DURING PRELIMINARY INSPECTIONS ON THE WORK SITE, IT IS ALSO BEST TO DETERMINE THE POSSIBILITY OF EASILY MOVING THE SHEETS INSIDE THE INSTALLATION PREMISES. ALL SIZES EXCEEDING 100 CM IN LENGTH OR WIDTH MUST BE HANDLED BY TWO INSTALLERS. FOR CORRECT SHEET MANAGEMENT, STARTING FROM PACKAGE OPENING, SUITABLE HANDLING DEVICES MUST BE USED. FOR MANUAL MOVEMENT AND SUBSEQUENT INSTALLATION OF LARGE SHEETS, TO ENSURE OPERATOR SAFETY AND MATERIAL INTEGRITY, THE USE IS STRONGLY ADVISABLE OF HANDLING BARS FEATURING SUCTION-CUPS. SPECIFIC HANDLING CARRIAGES ARE IDEAL ON THE WORKSITE AS “MAGAZINES” FOR ONE OF MORE SHEETS, AS WELL AS FOR SPREADING THE ADHESIVE ON THE REAR OF THE SHEETS IN TOTAL SAFETY.

SHEET CUTTING

CUTTING OPERATIONS ARE BEST PERFORMED ON A FLAT AND STABLE SURFACE. THE USE IS RECOMMENDED OF PROFESSIONAL CUTTING GUIDES WITH SCORING UNIT. ONCE THE SHEET HAS BEEN REMOVED FROM THE PACKAGING AND POSITIONED ON THE WORKTOP, THE PART TO BE REMOVED MUST BE MARKED AT THE TWO ENDS. POSITION AND BLOCK THE CUTTING GUIDE, TAKING INTO ACCOUNT THE DISTANCE OF THE CUTTING DISC. SCORE THE ENDS OF THE SHEET BY ABOUT 5 CM, PUSHING THE SCORING UNIT FROM INSIDE TOWARDS THE OUTSIDE. THEN PROCEED TO SCORE THE SHEET, BEING CAREFUL TO APPLY A PRESSURE AND A FORWARD MOVEMENT OF THE UNIT WHICH IS CONSTANT ALONG THE ENTIRE LENGTH OF THE CUT. MOVE THE SHEET SO AS TO BRING THE SCORE LINE OUTSIDE THE WORKTOP BY ABOUT 5/10 CM. REMOVE THE SCORING GUIDE AND START THE CUTTING-OFF OPERATION, POSITIONING THE SPECIFIC GRIPPER ON THE SCORE LINE; APPLY A SLIGHT AND GRADUAL PRESSURE DOWNWARDS. THIS OPERATION WILL PROVE TO BE VERY SIMPLE BECAUSE THE PRODUCTS ARE WITHOUT TENSIONING AND ARE THEREFORE EASY TO WORK. AT THIS POINT, FINISHING OPERATIONS CAN BEGIN USING DIAMOND HAND PADS OR, ALTERNATIVELY, ABRASIVE RESIN DISCS.

L CUTS / SLOTS / RECTANGULAR HOLES

MARK THE PORTION TO BE REMOVED ON THE SHEET AND, AFTERWARDS, AT THE LINE JOINING POINT, MAKE 6/8 DIAMETER HOLES USING WET DIAMOND CORE BITS. SUBSEQUENTLY JOINT THE HOLES USING AN ANGLE GRINDER FEATURING A DIAMOND DISC (MAX DIAMETER 125 MM).

GLUING

THE DOUBLE APPLICATION METHOD MUST BE USED, MEANING THE ADHESIVE MUST BE APPLIED BOTH ON THE INSTALLATION SURFACE AND ON THE BACK OF THE TILE. IT IS BEST TO USE A FULL-SPREAD CEMENT BASE ADHESIVE IN CLASS C2F S1/S2. MAKE SURE THE SURFACE TO BE COVERED IS CONSISTENT, FLAT, NOT GREASY AND DEVOID OF DUST. ELIMINATE ANY DUST THAT COULD COME INTO CONTACT WITH THE SHEETS. USING AN INCLINED-TOOTH SPATULA WITH MIN. 8 MM TOOTH, SPREAD THE ADHESIVE ON THE SURFACE TO BE COVERED WITH LINEAR, AND NEVER CIRCULAR MOVEMENTS. ON THE BACK OF THE SHEET INSTEAD, SPREAD THE ADHESIVE USING A TOOTHED SPATULA NEVER BELOW 5 MM (TAKING INTO ACCOUNT THAT THE SUM OF THE SPATULAS USED FOR SUBSTRATE AND SHEET MUST BE BETWEEN 13 AND 14 MM). TO CORRECTLY INSTALL MAXI&THIN, MAKE SURE THE AIR BUBBLES WHICH COULD FORM BETWEEN THE TILE AND THE ADHESIVE ARE REMOVED BY VIBRATION, UNTIL A “FULL SPREAD” OF ADHESIVE IS OBTAINED. AT THIS POINT, IT IS BEST TO USE A MANUAL RUBBER BEATER OR POWER TILE-BEATING DEVICES. THE ADHESIVE LAYER MUST BE AT LEAST 4 MM THICK AND CONSEQUENTLY LEVELLING SPACERS ARE BEST USED TO AVOID INTERRUPTIONS IN THE ADHESIVE MASS. AS REGARDS THE POSITION OF THE EXPANSION JOINTS, THE MINIMUM SUGGESTED JOINT IS 2 MM. IN THE CASE OF FLOORS AND WALLS IN CONTACT, TO INSTALL BOTH CERAMIC SHEETS AND ENSURE A LONG-LASTING RESULT, IT IS CRUCIAL TO MAINTAIN A MINIMUM WIDTH OF 2 MM. SMALLER JOINTS MAY BE MADE ON WALLS AFTER CARRYING OUT SPECIFIC TECHNICAL TESTS ON THE WORKSITE. AT LEAST 2/3 OF JOINT THICKNESS MUST BE FILLED WITH SPECIFIC SEALANT. MIND THERE IS NO ADHESIVE RESIDUE INSIDE THE JOINTS.

ANWENDUNGSDIEEN

EIN VIELSEITIGES FORMAT, DAS DANK TECHNISCHER MERKMALE WIE FESTIGKEIT, TEMPERATURWECHSELBESTÄNDIGKEIT UND EINFACHE VERARBEITUNG FÜR ZAHLREICHE EINSATZBEREICHE IDEAL IST. DAS GROSSFORMAT ERLAUBT DIE VERKLEIDUNG VON OBERFLÄCHEN MIT IMMER WENIGER FUGEN UND LÄSST EINE OPTISCHE KONTINUITÄT DER MATERIE ENTSTEHEN: DAS RESULTAT IST EIN RAUM, IN DEM ARCHITECTEN UND INTERIEUR DESIGNER PLANEN KÖNNEN, OHNE ABSTRICHE AN DIE SCHÖNHEIT UND QUALITÄT DER MATERIALIEN MACHEN ZU MÜSSEN.

VERLEGUNG/BEWEGUNG DER PLATTEN

WÄHREND DER VORAB-PRÜFUNGEN AUF DER BAUSTELLE IST AUCH SICHERZUSTELLEN, DASS DIE PLATTEN IN DEN VERLEGERÄUMEN PROBLEMLOS BEWEGT WERDEN KÖNNEN. ALLE FORMATE ÜBER 100 CM LÄNGE BZW. BREITE MÜSSEN VON 2 FLIESENLEGERN BEWEGT WERDEN. FÜR EIN KORREKTES HANDLING DER PLATTEN, ANGEFANGEN MIT DEM AUSPACKEN, SIND GEEIGNETE BEWEGUNGSMITTEL ZU VERWENDEN. FÜR DIE MANUELLE BEWEGUNG UND DIE ANSCHLESSENDE VERLEGUNG DER GROSSEN PLATTEN EMPFIEHLT SICH DRINGEND, ZUR GEWÄHRLEISTUNG DER SICHERHEIT DES PERSONALS UND DER UNVERSEHRTHEIT DES MATERIALS STANGEN MIT SAUGKÖPFEN ZU VERWENDEN. SPEZIELLE ROLLWAGEN SIND AUF DER BAUSTELLE IDEAL ALS „MAGAZIN“ FÜR EINE ODER MEHRERE PLATTEN, UND SIE ERLAUBEN AUCH, DEN KLEBER IN VÖLLIGER SICHERHEIT AUF DIE PLATTENRÜCKSEITE AUFZUTRAGEN.

SCHNEIDEN DER PLATTEN

DER SCHNITT SOLLTE AUF EINER STABILEN UND EBENEN FLÄCHE ERFOLGEN. WIR EMPFEHLEN DIE VERWENDUNG PROFESSIONELLER FÜHRUNGSSCHIENEN MIT RITZSCHLITTEN. NACH DEM AUSPACKEN DER PLATTE UND IHRER POSITIONIERUNG AUF DER ARBEITSFLÄCHE IST DAS ABZUSCHNEIDENDE STÜCK AN DEN BEIDEN ENDEN ZU MARKIEREN. DIE FÜHRUNGSSCHIE NE POSITIONIEREN UND BLOCKIEREN; DABEI DEN ABSTAND DER TRENNSCHEIBE BERÜCKSICHTIGEN. DIE PLATTENENDEN ETWA 5 CM LANG EINRITZEN UND DEN RITZSCHLITTEN DABEI VON INNEN NACH AUSSEN SCHIEBEN. ANSCHLIESSEND DIE PLATTE WEITER EINRITZEN UND DABEI DARAUF ACHTEN, DEN RITZSCHLITTEN ÜBER DIE GESAMTE SCHNITTLÄNGE KONSTANT ANZUDRÜCKEN UND VORZUSCHIEBEN. DIE PLATTE SO VERSCHIEBEN, DASS DIE RITZLINIE SICH UM CIRCA 5-10 CM AUSSERHALB DER ARBEITSFLÄCHE BEFINDET. FÜHRUNGSSCHIE NE ENTFERNEN UND MIT DEM ABTRENNEN BEGINNEN, INDEM DIE ZANGE AN DER RITZLINIE ANGESETZT WIRD; LEICHTEN UND ZUNEHMENDEN DRUCK NACH UNTEN AUSÜBEN. DIESER VORGANG IST SEHR EINFACH, DA DIE FRAGMENTS-PLATTEN SPANNUNGSFREI SIND UND SICH DAHER LEICHT BEARBEITEN LASSEN. NUN KANN DAS SCHLEIFEN BEGINNEN, WOZU ENTSPRECHENDE DIAMANT-SCHLEIFKISSEN ODER GEHARTZTE SCHLEIFSCHEI BEN ZU VERWENDEN SIND.

L-SCHNITTE / AUSSCHNITTE/RECHTECKIGE BOHRUNGEN

DEN ZU ENTFERNENEN TEIL AUF DER PLATTE ANREISSEN UND ANSCHLIESSEND AM SCHNITTPUNKT DER LINIEN MIT DER DIAMANTSTICHSÄGE BOHRUNGEN MIT DURCHMESSER 6/8 NASS AUSFÜHREN. DIE BOHRUNGEN NUN MIT EINEM WINKELSCHLEIFER MIT DIAMANTSCHLEIFSCHEI BE (MAX. DURCHMESSER 125 MM) VERBINDEN.

VERKLEBEN

ERFOLGT BEIDSEITIG, DAS HEISST DER KLEBER MUSS SOWOHL AUF DEM VERLEGEUNTERGRUND ALS AUCH AUF DER PLATTENRÜCKSEITE AUFGETRAGEN WERDEN. ES EMPFIEHLT SICH ZEMENTKLEBER DER KLASSE C2F S1/S2, DER BLASENFREI AUFGETRAGEN WIRD. ES IST SICHERZUSTELLEN, DASS DIE ZU VERFLIESENDE OBERFLÄCHE FEST UND EBEN, FETT- UND STAUBFREI IST. EVENTUELLEN STAUB VON DEN PLATTEN BESEITIGEN. DEN KLEBER MIT EINER ZAHNSPACHTEL MIT SCHRÄGZAHNUNG VON MINDESTENS 8 MM MIT GERADLINIGEN UND NIEMALS KREISFÖRMIGEN BEWEGUNGEN AUF DIE ZU VERKLEIDENDE OBERFLÄCHE AUFTRAGEN. AUF DER PLATTENRÜCKSEITE WIRD DER KLEBER DAGEGEN MIT EINER ZAHNSPACHTEL VON MINDESTENS 5 MM AUFGETRAGEN (ES IST ZU BEACHTEN, DASS DIE SUMME DER FÜR UNTERGRUND UND PLATTE VERWENDETEN SPACHTELZÄHNE ZWISCHEN 13 UND 14 MM LIEGEN MUSS). FÜR EINE KORREKTE VERLEGUNG VON MAXI&THIN SIND DURCH RÜTTELN DIE LUFTBLASEN, DIE ZWISCHEN FLIESE UND KLEBER ENTSTEHEN KÖNNEN, ZU BESEITIGEN, BIS EIN KOMPAKTES, BLASENFREIES KLEBERBETT ENTSTEH T. IN DIESER PHASE SOLLTEN EIN MANUELLER GUMMIKLOPFER ODER ELEKTRISCHE FLIESENKLOPFER VERWENDET WERDEN. DIE KLEBERSCHICHT MUSS WENIGSTENS 4 MM DICK SEIN; DESHALB SOLLTEN NIVELLIER-DISTANZSTÜCKE VERWENDET WERDEN, DAMIT KEINE UNTERBRECHUNGEN IN DER KLEBERMASSE ENTSTEHEN. DEHNUNGSFUGEN SOLLTEN MINDESTENS 2 MM BREIT SEIN. WERDEN WAND UND BODEN ANEINANDERNERTOSSEND VERFLIEST, SO IST FÜR EIN DAUERHAFTES ERGEBNIS EINE FUGENBREITE VON MINDESTENS 2 MM UNERLÄSSLICH. ES IST GÖMLICH, NACH ENTSPRECHENDEN TECHNISCHEN PRÜFUNGEN VOR ORT AN DER WAND EVENTUELL SCHMALER ZU VERFUGEN. DIE FUGEN SIND ZU WENIGSTENS 2/3 DER FLIESENSTÄRKE MIT DER ENTSPRECHENDEN FUGENMASSE ZU FÜLLEN. ES IST AUF EVENTUELLE KLEBERRÜCKSTÄNDE IN DEN FUGEN ZU ACHTEN.

CONSEILS D’UTILISATION

GRACE A SES CARACTERISTIQUES TECHNIQUES DE ROBUSTESSE, RESISTANCE AUX ECARTS THERMIQUES ET FACILITE DE PREPARATION, CE FORMAT POLYVALENT EST L'IDEAL POUR DE NOMBREUSES APPLICATIONS.SA TAILLE PERMET DE REVETIR LES SURFACES EN CONFECTIONNANT MOINS DE JOINTS, D'OU LA PERCEPTION VISUELLE D'UNE CONTINUITE DE LA MATIERE. LE RESULTAT EST PARTICULIEREMENT APPRECIABLE : UN ESPACE OUVERT A LA CONCEPTION DES ARCHITECTES D'INTERIEUR ET DES DESIGNERS QUI NE DOIVENT RENONCER NI A LA BEAUTE NI A LA QUALITE DES MATERIAUX.

POSE / MANUTENTION DES DALLES

LORS DES VERIFICATIONS PRELIMINAIRES SUR LE CHANTIER VEILLER A ASSURER AUSSI LA FACILITE DE DEPLACEMENT DES DALLES A L'INTERIEUR DES LIEUX DE POSE. POUR QUE LA MANUTENTION DES DALLES SOIT EFFECTUEE CORRECTEMENT, TOUS LES FORMATS DEPASSANT 100 CM, AUSSI BIEN EN LONGUEUR QU'EN LARGEUR, DOIVENT ETRE DEPLACES PAR 2 POSEURS. DES LA PHASE D'OUVERTURE DES EMBALLAGES, UTILISER DES APPAREILS DE MANUTENTION APPROPRIES. LORS DU DEPLACEMENT MANUEL ET DE LA MISE EN ŒUVRE DES DALLES DE GRANDES DIMENSIONS, AFIN DE GARANTIR LA SECURITE DES OUVRIERS ET LE BON ETAT DU MATERIAU, IL EST VIVEMENT CONSEILLE D'UTILISER DES BARRES DE MANUTENTION A VENTOUSES. LES CHARIOTS DE MANUTENTION UTILISES SUR LE CHANTIER PEUVENT SERVIR DE “MAGASIN” POUR UNE OU PLUSIEURS DALLES ET PERMETTENT EN TOUTE SECURITE D'ETALER LA COLLE SUR L'ENVERS DE LA DALLE.

COUPE DES DALLES

CETTE OPERATION DOIT ETRE EFFECTUEE SUR UNE SURFACE PLANE, STABLE ET CONSISTANTE. IL EST CONSEILLE D'UTILISER DES GUIDES DE DECOUPEGE PROFESSIONNELS A CHARIOT INCISEUR. UNE FOIS QUE LA DALLE EST SORTIE DE SON EMBALLAGE ET QU'ELLE EST POSITIONNEE SUR LE PLAN DE TRAVAIL, MARQUER AUX DEUX EXTREMITES LA COTE A ENLEVER. POSITIONNNER ET BLOQUER LE GUIDE DE DECOUPEGE EN TENANT COMPTE DE LA DISTANCE DU DISQUE DE COUPE. DECOUPER LES EXTREMITES DE LA DALLE SUR ENVIRON 5 CM EN POUSSANT LE CHARIOT D'INCISION DE L'INTERIEUR VERS L'EXTERIEUR. PASSER ENSUITE AU DECOUPEGE DE LA DALLE EN VEILLANT BIEN A EXERCER UNE PRESSION ET UN AVANCEMENT CONSTANTS DU CHARIOT SUR TOUTE LA LONGUEUR DE LA COUPE. DEPLACER LA DALLE DE MANIERE A PORTER LA LIGNE DE COUPE EN DEHORS DU PLAN DE TRAVAIL D'ENVIRON 5/10 CM. ENLEVER LE GUIDE-COUCPE ET COMMENCER L'OPERATION DE TRONCONNAGE EN POSITIONNANT LA PINCE SPECIALE AU NIVEAU DE LA LIGNE D'INCISION. EXERCER UNE PRESSION LEGERE ET PROGRESSIVE VERS LE BAS. CETTE OPERATION SERA TRES SIMPLE PARCE QUE LES PRODUITS FRAGMENTS NE PRESENTENT PAS DE TENSIONS ET QU'ILS SONT DE CE FAIT FACILES A TRAVAILLER. PROCEDER ALORS A LA FINITION QUI DEVRA ETRE EFFECTUEE EN UTILISANT LES TAMPONS DIAMANTES SPECIAUX OU, A LEUR PLACE, DES DISQUES ABRASIFS RESINEUX.

DECOUPES EN L/ EN PROFONDEUR /TROUS RECTANGULAIRES

MARQUER LA PARTIE A ENLEVER SUR LA DALLE ET EFFECTUER ENSUITE, AU NIVEAU DU POINT DE JONCTION DES LIGNES, DES TROUS DE 6/8 CM DE DIAMETRE A L'AIDE DE FORETS DIAMANTES, EN HUMIDE. REUNIR ENSUITE LES TROUS AVEC UNE PONCEUSE D'ANGLE EQUIPEE D'UN DISQUE DIAMANTE (DIAMETRE MAX. 125 MM)

ENCOLLAGE

UTILISER LA TECHNIQUE DU DOUBLE ENCOLLAGE C'EST-A-DIRE QUE LA COLLE DOIT ETRE APPLIQUEE A LA FOIS SUR LE FOND DE POSE ET SUR L'ENVERS DU CARREAU. IL EST CONSEILLE D'UTILISER UNE COLLE A BASE DE CIMENT A LIT PLEIN, CLASSE C2F S1/S2. S'ASSURER QUE LA SURFACE A RECOUVRI R EST BIEN CONSISTANTE, PLANE, SANS TRACE DE GRAISSE NI DE POUSSIERE. ELIMINER LA POUSSIERE QUI POURRAIT SE TROUVER A LA SURFACE DES CARREAUX. AVEC UNE SPATULE CRANTEE A DENTS INCLINEES D'AU MOINS 8 MM, ETALER LA COLLE SUR LA SURFACE DE REVETEMENT EN EFFECTUANT DES MOUVEMENTS LINEAIRES, JAMAIS CIRCULAIRES. PAR CONTRE, SUR LE DOS DU CARREAU, ETALER LA COLLE EN UTILISANT UNE SPATULE CRANTEE DONT LES DENTS SONT AU MOINS DE 5 MM (NE PAS OUBLIER QUE LA SOMME DES SPATULES UTILISEES POUR LA SOUS-COUCHE ET LA DALLE DOIT ETRE COMPRISE ENTRE 13 ET 14 MM). POUR REALISER CORRECTEMENT LA POSE DE MAXI&THIN IL EST RECOMMANDE DE CHASSER, PAR VIBRATION, LES BULLES D'AIR SUSCEPTIBLES DE SE FORMER ENTRE LE CARREAU ET LA COLLE DE MANIERE A OBTENIR UNE COUCHE DE COLLE “PLEINE”. POUR CETTE PHASE IL EST CONSEILLE D'UTILISER UN BATTEUR MANUEL EN CAOUTCHOUC OU ENCORE LES DISPOSITIFS ELECTRIQUES DE DAMAGE DES CARREAUX. LA COUCHE DE COLLE DOIT ETRE AU MOINS DE 4 MM. IL EST DONC PREFERABLE D'UTILISER DES ENTRETOISES DE NIVELLEMENT POUR EVITER TOUTE INTERRUPTION DANS LA MASSE COLLANTE. POUR CE QUI EST DE LA POSITION DES JOINTS DE DILATATION, LE JOINT MINIMUM CONSEILLE EST DE 2 MM. DANS LE CAS DE CARRELAGES DE SOLS ET DE MURS EN CONTACT, REALISES TOUS LES DEUX AVEC DES DALLES CERAMIQUES, IL EST IMPERATIF DE PREVOIR UNE LARGEUR MINIMALE DE 2 MM POUR OBTENIR UN RESULTAT DURABLE DANS LE TEMPS. IL EST POSSIBLE LE CAS ECHEANT DE REALISER DES JOINTS INFERIEURS AU REVETEMENT APRES AVOIR EFFECTUE LES VERIFICATIONS TECHNIQUES SUR LE CHANTIER. IL EST RECOMMANDE DE REMPLIR LES JOINTS SUR ENVIRON 2/3 DE L'EPAISSEUR AVEC LE PRODUIT DE SCELEMENT ADEQUAT. EVITER TOUTE PRESENCE DE RESIDUS DE COLLE A L'INTERIEUR DES JOINTS.

Dati Tecnici

TECHNICAL DATA



377 INDEX

Strumenti di movimentazione

Handling toolse
Handhabungsgeräte
Équipements de manutention

STRUMENTI DI MOVIMENTAZIONE

GLI STRUMENTI PER IL SOLLEVAMENTO E LA MOVIMENTAZIONE DELLE LASTRE SONO DA SCEGLIERE IN FUNZIONE DELLA DIMENSIONE DELLA LASTRA E DELLE ATTIVITÀ DA SVOLGERE IN CANTIERE PRESSO IL MAGAZZINO DI STOCCAGGIO, IN PARTICOLARE:

- CARRELLO ELEVATORE CON FORCHE LUNGHE 2,5 MT (ANCHE TRAMITE PROLUNGA).
- BARRE / TELAIO DI MOVIMENTAZIONE CON VENTOSE PER FORMATI FINO A 120X280 CM.

A - MOVIMENTAZIONE TRAMITE CARRELLO ELEVATORE A FORCHE LUNGHE. PER UNA CORRETTA MOVIMENTAZIONE DI CASSE E CAVALLETTI È NECESSARIO L'UTILIZZO DI UN CARRELLO ELEVATORE A FORCHE CON UNA LUNGHEZZA DI ALMENO 2,5 MT, UTILIZZANDO EVENTUALMENTE APPOSITE PROLUNGHE. PER CONSENTIRE IL TRASFERIMENTO DELLE LASTRE IN TOTALE SICUREZZA, VERIFICARE CHE INTORNO AL PALLET VI SIANO SPAZI SUFFICIENTI PER LE MANOVRE DEL CARRELLO ELEVATORE.

B - MOVIMENTAZIONE TRAMITE BARRE - TELAIO CON VENTOSE. PER LA MOVIMENTAZIONE MANUALE E LA SUCCESSIVA POSA IN OPERA DELLE LASTRE, AL FINE DI GARANTIRE SICUREZZA PER GLI OPERATORI E INTEGRITÀ DELLE LASTRE, È VIVAMENTE CONSIGLIATO L'UTILIZZO DI BARRE O TELAIO DI MOVIMENTAZIONE CON VENTOSE DI SICUREZZA DOTATO DI CARRELLO PER IL TRASPORTO (IDEALI PER LASTRE DI FORMATI FINO A 120X280 CM). SU ARTICOLI DI DIMENSIONI INFERIORI (ESEMPIO 120X120 CM) PUÒ ESSERE SUFFICIENTE L'UTILIZZO BIVENTOSE O MONOVENTOSE CON VUOTOMETRO.

STRUMENTI

Toolse

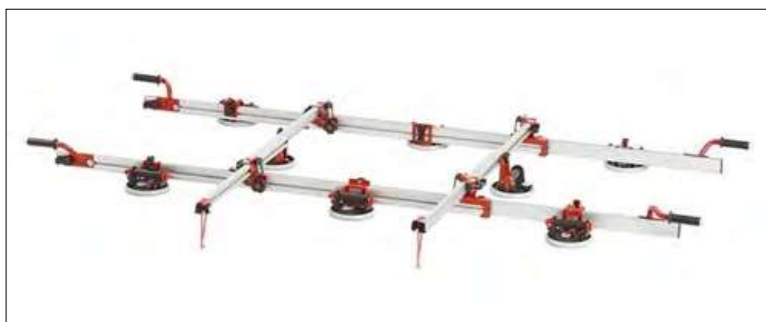

BARRE / TELAIO DI MOVIMENTAZIONE

CON VENTOSE PER FORMATI FINO A 160X320 CM.

SUCTION CUP HANDLING BARS / FRAME

FOR SIZES UP TO 160X320 CM.

HANDLING TOOLSE

THE EQUIPMENT TO BE USED FOR LIFTING AND HANDLING SLABS SHOULD BE CHOSEN ON THE BASIS OF THE SLAB'S SIZE AND THE INTENDED ACTIVITIES IN THE CONSTRUCTION SITE OR STORAGE WAREHOUSE, AND MAY BE:

- FORKLIFT TRUCK WITH FORKS 2.5 METRES LONG (WITH THE AID OF EXTENSIONS, IF NECESSARY).
- SUCTION CUP HANDLING BARS / FRAME FOR HANDLING SLABS UP TO SIZE 120X280 CM.

A - HANDLING BY FORKLIFT TRUCK WITH LONG FORKS. FOR CORRECT HANDLING OF CRATES AND A-FRAMES, A FORKLIFT TRUCK WITH FORK LENGTH AT LEAST 2.5 METRES IS REQUIRED, WITH THE USE OF THE APPROPRIATE EXTENSIONS IF NECESSARY. TO ENSURE THAT THE SLABS ARE TRANSPORTED IN COMPLETE SAFETY, CHECK THAT THERE IS SUFFICIENT SPACE AROUND THE PALLET TO ALLOW THE FORKLIFT TRUCK TO MANOEUVRE.

B - HANDLING BY SUCTION CUP HANDLING BARS - FRAME. FOR MANUAL HANDLING AND SUBSEQUENT POSITIONING OF SLABS, THE USE OF HANDLING BARS / FRAME WITH SAFETY SUCTION CUPS (IDEAL FOR SLABS SIZE 120X280), WITH TRANSPORTER TROLLEY, WITH CROSSPIECES BETWEEN THE BARS IF NECESSARY, IS STRONGLY RECOMMENDED TO ENSURE WORKERS' SAFETY AND PREVENT DAMAGE TO SLABS. SMALLER ARTICLES (E.G. 120X120 CM) CAN BE HANDLED SIMPLY WITH THE AID OF TWO DOUBLE SUCTION-CUP LIFTERS FOR HANDLING SMOOTH OR POLISHED MATERIALS, OR TWO SPECIAL SINGLE PAD VACUUM LIFTERS FOR HANDLING MATERIALS WITH STRUCTURED SURFACE.



CARRELLO DI MOVIMENTAZIONE

PREDISPOSTO PER ESEGUIRE LA STESURA DELLA COLLA SUL RETRO LASTRA.

HANDLING TROLLEYS

DESIGNED TO ALLOW APPLICATION OF ADHESIVE TO THE BACK OF THE SLAB.

HANDHABUNGSGERÄTE

DIE GERÄTE ZUM HEBEN UND HANDHABEN DER PLATTEN SIND IN FUNKTION DER PLATTENABMESSUNGEN UND DER AUF DER BAU-STELLE ODER IM LAGERRAUM AUSZUFÜHRENDEN AKTIVITÄTEN ZU WÄHLEN, INSBESONDERE:

- STAPLER MIT 2,5 M GABELLÄNGE (AUCH MITTELS VERLÄNGERUNG).
- TRAGSTANGEN / TRAGRAHMEN FÜR DIE HANDHABUNG MIT SAUGHEBERN FÜR FORMATE BIS 120X280 CM.

A - HANDHABUNG MITTELS STAPLER MIT LANGER GABEL. FÜR EINE KORREKTE HANDHABUNG VON KISTEN UND TRANSPORTBÖCKEN IST EIN GABELSTAPLER MIT EINER GABELLÄNGE VON MINDESTENS 2,5 M ZU VERWENDEN, DIE LÄNGE KANN GGF. MIT VERLÄNGERUNGEN ERREICHT WERDEN. UM EINE PLATTENBEFÖRDERUNG IN VOLLER SICHERHEIT ZU ERMÖGLICHEN, IST ZU PRÜFEN, DASS RUND UM DIE PALETTE EIN AUSREICHENDER FREIRAUM FÜR DIE MANÖVER DES GABELSTAPLERS VORHANDEN IST.

B - HANDHABUNG MIT TRAGSTANGEN - TRAGRAHMEN MIT SAUGHEBERN. FÜR DIE MANUELLE HANDHABUNG UND ANSCHLIESENDE VERLEGUNG, WIRD ZUR GEWÄHRLEISTUNG DER BEDIENER-SICHERHEIT UND DES EINWANDFREIEN ZUSTANDES DER PLATTEN NACHDRÜCKLICH EMPFOHLEN, TRAGSTANGEN ODER EINEN TRAGRAH-MEN MIT SICHERHEITS-SAUGHEBERN ZU BENUTZEN, DIE MIT EINEM TRANSPORTWAGEN AUSGESTATTET SIND (IDEAL FÜR PLATTEN IN FORMATEN BIS 120X280 CM). FÜR ARTIKEL MIT GERINGEN ABMESSUNGEN (Z.B. 120X120 CM) KÖNNTE DIE VERWENDUNG VON DOPPELSAUGHEBERN ODER EINZELSAUGHEBERN MIT VAKUUMMETER AUSREICHEND SEIN.

MOVIMENTAZIONE TRAMITE CARRELLO ELEVATORE A FORCHE LUNGHE

Handling by forklift truck with long forks



PER MOVIMENTARE CORRETTAMENTE IL PALLET SUL LATO LUNGO SI RACCOMANDA DI ALLARGARE AL MASSIMO LE FORCHE E DI POSIZIONARLE AL CENTRO DEL PALLET, FAR PRESA SU TUTTA LA PROFONDITÀ PRIMA DI SOLLEVARE.

FOR CORRECT HANDLING OF THE PALLET ON THE LONG SIDE, THE FORKS MUST BE WIDENED TO THEIR MAXIMUM SETTING AND PLACED IN THE CENTRE OF THE PALLET; ENSURE CONTACT THROUGH THE ENTIRE DEPTH BEFORE LIFTING.



PER MOVIMENTARE CORRETTAMENTE IL PALLET SUL LATO CORTO (AD ESEMPIO NELLO SCARICO DEI CONTAINERS) È RACCOMANDATO L'UTILIZZO DI FORCHE LUNGHE ALMENO 2,5 MT, QUESTO GARANTISCE UNA PERFETTA PRESA E SICUREZZA DEL MATERIALE.

FOR CORRECT HANDLING OF THE PALLET ON THE SHORT SIDE (E.G. WHEN UNLOADING CONTAINERS), FORKS AT LEAST 2.5 METRES LONG SHOULD BE USED TO ENSURE THAT THE MATERIAL IS HELD PERFECTLY AND SAFELY.

ÉQUIPEMENTS DE MANUTENTION

LES ÉQUIPEMENTS DE LEVAGE ET DE DÉPLACEMENT DES DALLES DOIVENT ÊTRE CHOISIS EN FONCTION DES DIMENSIONS DE CELLES-CI ET DES ACTIVITÉS À METTRE EN OEUVRE SUR LE CHANTIER ET DANS L'ENTREPÔT DE STOCKAGE; ON PEUT MENTIONNER:

- CHARIOT ÉLÉVATEUR DOTÉ DE FOURCHES DE 2,5 M DE LONGUEUR (LE CAS ÉCHÉANT DOTÉES DE RALLONGES).
- BARRES / CHÂSSIS DE MANUTENTION DOTÉS DE VENTOUSES POUR FORMATS JUSQU'À 120X280 CM.

A - DÉPLACEMENT EFFECTUÉ AVEC CHARIOT ÉLÉVATEUR À FOURCHES LONGUES. POUR EFFECTUER CORRECTEMENT LE DÉPLACEMENT DE CAISSES ET CHEVALETS, IL EST NÉCESSAIRE D'UTILISER UN CHARIOT ÉLÉVATEUR DOTÉ DE FOURCHES D'UNE LONGUEUR D'AU MOINS 2,5 M, EN UTILISANT ÉVENTUELLEMENT DES RALLONGES PRÉVUES À CET EFFET. POUR PERMETTRE LE DÉPLACEMENT DES DALLES EN CONDITIONS DE SÉCURITÉ ABSOLUE, S'ASSURER DE LA PRÉSENCE AUTOUR DE LA PALETTE DE L'ESPACE NÉCESSAIRE AUX MANOEUVRES DU CHARIOT ÉLÉVATEUR.

B - DEPLACEMENT EFFECTUÉ AVEC BARRES CHÂSSIS A VENTOUSES. POUR LE DÉPLACEMENT MANUEL PUIS POUR LA POSE DES DALLES, AFIN DE GARANTIR LA SÉCURITÉ DES OPÉRATEURS ET L'INTÉGRITÉ DES DALLES, IL EST VIVEMENT RECOMMANDÉ D'UTILISER DES BARRES OU DES CHÂSSIS DE MANUTENTION À VENTOUSES DE SÉCURITÉ DOTÉS DE CHARIOT DE TRANSPORT (SYSTÈME IDÉAL POUR LES DALLES DE FORMAT JUSQU'À 120X280 CM). POUR LES PRODUITS DE DIMENSIONS INFÉRIEURES (120X120 CM PAR EXEMPLE), DES MONOVENTOUSES OU DES VENTOUSES DOUBLES À VIDE PEUVENT SUFFIRE.

PER PRESERVARE L'INTEGRITÀ DELLE LASTRE NON SOVRAPPORRE VOLUMI DIVERSI SULLE CASSE.

TO PREVENT DAMAGE TO SLABS, DO NOT STACK ITEMS OF DIFFERENT SIZES ON TOP OF THE CRATES.

Imballaggi in cassa di legno 120x280 cm

Packaging in wooden crate 120x280
Verpackung in Holzkisten 120x280
Conditionnement en caisse de bois 120x280

LE LASTRE PIEMME VENGONO IMBALLATE IN CASSE DI LEGNO DA:

- 294x143x35, pezzi cassa da 9-20,
- 292x143x25, pezzi cassa da 1-8.

PIEMME SLABS PROJECT PRODUCTS ARE PACKED IN WOODEN CRATES:

- 294x143x35, 9-20 pieces/wooden box,
- 292x143x25, 1-8 pieces/wooden box.

DIE PRODUKTE DES PIEMME SLABS PROJECT WERDEN IN HOLZKISTEN VERPACKT:

- 294x143x35, 9-20 Stk/Kiste,
- 292x143x25, 1-8 Stk/Kiste.

LES PRODUITS DU PROJET PIEMME SLABS SONT EMBALLÉS DANS DES CAISSES EN BOIS:

- 294x143x35, caisse pièces de 9-20,
- 292x143x25, pièces de 1-8.

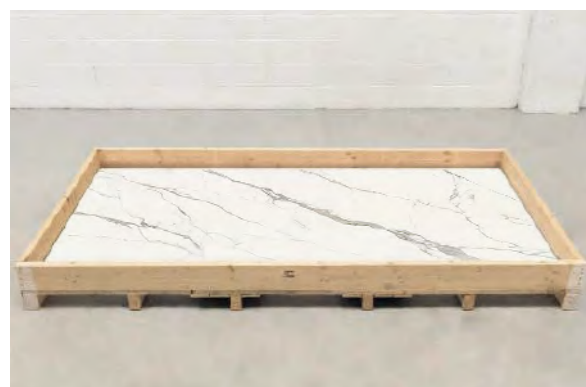

Imballaggi in cavalletto 120x280 - 120x120 cm

Packaging on a - frame 120x280 - 120x120
Verpackung auf Transportgestell 120x280 - 120x120
Emballage en chevalet 120x280 - 120x120

IL CAVALLETTO E' UN'ALTERNATIVA DI IMBALLAGGIO PER LE LASTRE 120x120 - 120x280:

- 292x160x75, formato lastra 120x280x0,6 cm,
- 122x136,8x75, formato lastra 120x120x0,85 cm.

A - FRAME IS AN ALTERNATIVE PACKAGING FOR THE SLABS 120x120 - 120x280:

DAS TRANSPORTGESTELL IST EINE ALTERNATIVE ZUR VERPACKUNG FÜR PLATTEN 120x120-120x280:

LE CHEVALET EST UNE ALTERNATIVE D' EMBALLAGE POUR LES DALLES 120x120 - 120x280:



STOCCAGGIO CASSE / Crates storage

PER SALVAGUARDARE LA CONSERVAZIONE DELLE CASSE SUGGERIAMO DI IMPILARLE E PROTEGGERLE IN UN LUOGO COPERTO.

TO KEEP THE CRATES IN GOOD CONDITION, THEY SHOULD BE STACKED AND PROTECTED IN AN INDOOR LOCATION.

UM DEN GUTEN ZUSTAND DER KISTEN AUFRECHT ZU ERHALTEN, EMPFEHLEN WIR, SIE AN EINEM ÜBERDÄCHTEN ORT ZU STAPELN UND ZU SCHÜTZEN, DENN BEIM VERLADEN UND STAPELN IN DEN LKW BZW.

POUR LA BONNE CONSERVATION DES CAISSES, IL EST RECOMMANDÉ DE LES EMPILER ET DE LES PROTÉGER À UN ENDROIT COUVERT.

Imballo Lastre Packaging of slabs Emballage des plaques Verpackungskosten Grossformate

Formato Lastra Slab Size Format Format	Pezzi per Imballo Pieces Pièces Stückzahl	Nome Cassa Name Crate Nome Caisse Name Holzkiste	Ingombro Dimensions Dimensions Abmessung	Peso casse vuote KG Empty crate weight KG Poids caisses vides KG Gewicht leerer kisten KG
1200x2800	1-8	Cassa PICCOLA h25	292x143x25	45 KG
1200x2800	9-20	Cassa GRANDE h35	294x143x35	85 KG

Imballo Lastre Packaging of slabs Emballage des plaques Verpackungskosten Grossformate

Formato Lastra Slab Size Format Format	Pezzi per Imballo Pieces Pièces Stückzahl	Nome Cavalletto Name A-Frame Nome Chevalet Name Transportgestell	Ingombro Dimensions Dimensions Abmessung	Peso cavalletti vuoti KG Empty A-Frames weight KG Poids chevalets vides KG Gewicht leeres Transportgestell KG
1200x2800	40	Cavalletto 120x280	292x75x160H	185 KG
1200x1200	72	Cavalletto 120x120	122x75x136,8H	95 KG

Gres Fine Porcellanato

È la suprema sintesi di tecnica ed estetica. La scelta delle migliori materie prime, la cottura a 1250° C e l'intero controllo del ciclo produttivo assicurano infatti a questi materiali caratteristiche tecniche di assoluto rilievo, rendendoli estremamente duri, inassorbenti, ingelivi, resistenti all'usura, agli attacchi chimici e facilmente pulibili.

Classificazione secondo norme CEN/ISO gruppo BIA EN 14411/ISO 13006.

Porcelain Stoneware

Piemme fine porcelain stoneware is a supreme blend of technology and good looks. The choice of the very best raw materials, firing at 1250° c and total manufacturing cycle control do in fact provide these materials with top-ranking technical features, making them hard, non-absorbent, frost-proof, resistant to wear and chemical attack and easy to clean. Classification in accordance with cen/iso standards BIA EN 14411/ISO 13006

Feinsteinzeug

Das Feinsteinzeug Piemme ist eine vortreffliche Verschmelzung von Technik und Ästhetik. Denn die Wahl bester Rohstoffe, der Brand bei 1250° C und die gesamte Kontrolle des Produktionszyklus garantieren für diese Fliesen hervorragende technische Eigenschaften. Das Material ist hart, absorptionsfrei, frostbeständig, verschleiß- und chemikalienfest sowie reinigungsfreundlich. Klassifizierung gemäß CEN/ISO Normen Gruppe BIA EN 14411/ISO 13006.

Grès Cérame

Le grès cérame fin Piemme est l'alliance par excellence de la technique et de l'esthétique. En effet, le choix des meilleures matières premières, la cuisson à 1250° C et tous les contrôles effectués pendant la production assurent à ces matériaux des caractéristiques techniques tout à fait remarquables, les rendent extrêmement durs, inabsorbants, ingélifs, résistant à l'usure, aux attaques chimiques et faciles à nettoyer. Classification selon les normes CEN/ISO groupe BIA EN 14411/ISO 13006

Фарфоровый керамогранит

Это – наивысшее выражение техники и эстетики. Выбор наилучшего сырья, обжиг при 1250°С и полный контроль производственного цикла гарантируют этим материалам выдающиеся технические характеристики, делая их чрезвычайно твердыми, не впитывающими влагу, незамерзающими, стойкими к износу и химическому воздействию, легко очищающимися. Классификация по стандартам CEN/ISO: группа BIA EN 14411/ISO 13006.

Pasta Bianca

La pasta bianca è la naturale evoluzione del rivestimento. L'alta qualità dei materiali, le alte temperature di cottura permettono di ottenere bellezza di superfici e grandi formati da rivestimento.

Classificazione secondo norme CEN/ISO gruppo BIII EN 14411/ISO 13006.

White Body

The natural evolution of wall tile. The fine quality of materials, the high firing temperatures achieve beauty of surfaces and big sizes in wall tiles.

Classification in accordance with CEN/ISO standards BIII EN 14411/ISO 13006.

Weißscherbig

Die natürliche Entwicklung der Wandfliese. Die ausgezeichnete Materialienqualität, die hohe Brenntemperaturen erwirken Oberflächen-Schönheit und große Formate bei Wandfliesen.

Klassifizierung gemäß CEN/ISO Normen Gruppe BIII EN 14411/ISO 13006.

Pâte Blanche

Naturelle évolution du revêtement. La haute qualité des matériaux, les températures élevées de cuisson permettent d'obtenir la beauté des surfaces et de grands formats pour revêtement.

Classification selon les normes CEN/ISO groupe BIII EN 14411/ISO 13006.

Плитка Из Белой Глины

Плитка из белой глины – это естественная эволюция облицовочной плитки. Высокое качество материалов и высокая температура обжига позволяют получать красивые поверхности и большие форматы облицовочного материала. Классификация по стандартам CEN/ISO: группа BIII EN 14411/ISO 13006.

CLASSIFICAZIONE SECONDO NORME CEN/ISO GRUPPO BIA EN 14411/ISO 13006.		CLASSIFICATION IN ACCORDANCE WITH CEN/ISO STANDARDS BIA EN 14411/ISO 13006.		KLASSIFIZIERUNG GEMÄSS CEN/ISO NORMEN GRUPPE BIA EN 14411/ISO 13006.		CLASSIFICATION SELON LES NORMES CEN/ISO GROUPE BIA EN 14411/ISO 13006.	
*VALORE PRESCRITTO: EN 14411 APPENDICE G - ISO 13006 - BIA		*REQUIRED VALUE: EN 14411 APPENDICE G - ISO 13006 - BIA		*VORGESCHRIEBENER WERT: EN 14411 APPENDICE G - ISO 13006 - BIA		*VALEUR PRESCRITE: EN 14411 APPENDICE G - ISO 13006 - BIA	
Proprietà Fisico-Chimiche Physical-Chemical Properties Pysisch-Chemische Eigenschaften Propriétés Physico-Chimiques	Tipo Di Prova Standard Of Test Testnorm Norme Du Test	Valore Prescritto* Required Value Vorgeschriebener Wert Valeur Prescrite	Valore Standards Norm Norm Normr	Valore medio Mean value Mittelwert Valeur moyenne			
Lunghezza e larghezza Length and width Länge und breite Longueur et largeur	Iso 10545.2	± 0,6% (± 2,00 mm)	Conforme In accordance Erfüllt Conforme	Astm C-499 Astm C-485 Astm C-502	In Accordance		
Ortogonalità Wedging Rechtwinkligkeit Orthogonalité	Iso 10545.2	± 0,5% (± 2,00 mm)	Conforme In accordance Erfüllt Conforme	Astm C-499 Astm C-485 Astm C-502	In Accordance		
Spessore Thickness Stärke Epaisseur	Iso 10545.2	± 5% (± 0,50 mm)	Conforme In accordance Erfüllt Conforme	Astm C-499 Astm C-485 Astm C-502	In Accordance		
Planarità Flatness Ebenflächigkeit Planéité	Iso 10545.2	± 0,5% (± 2,00 mm)	Conforme In accordance Erfüllt Conforme	Astm C-499 Astm C-485 Astm C-502	In Accordance		
Assorbimento d'acqua Water absorption Wasseraufnahme Absorption d'eau	Iso 10545.3	≤ 0,5%	Conforme In accordance Erfüllt Conforme	Astm C-373	In Accordance		
Coefficiente di dilatazione termica lineare Coefficient of linear thermal-expansion Lineare wärmeausdehnung Coefficient linéaire de dilatation thermique	Iso 10545.8	Secondo i dati del costruttore According to builder's specifications Lautangaben des herstelllers Selon les elements du constructeur	6,7X10 ⁻⁶ C ⁻¹				
Resistenza a flessione Flexion resistance Biegezugfestigkeit Résistance à la flexion	Iso 10545.4	Modulus of rupture (average): ≥ 35 N/mm ² Breaking strength for thickness ≥7,5mm: S >1300 N Breaking strength for thickness <7,5mm: S >700 N	Conforme In accordance Erfüllt Conforme	Astm C-648 250 Lbs or greater	In Accordance		
Resistenza agli sbalzi termici Thermal shock resistance Temperaturwechselbeständigkeit Résistance aux écarts de température	Iso 10545.9	Richiesta Request Bitte Demande	Resistente Resistant Widerstehend Résistant				
Resistenza ai prodotti chimici Chemical resistance Chemikalienfestigkeit Résistance aux produits chimiques	Iso 10545.13	Secondo i dati del costruttore According to builder's specifications Lautangaben des herstelllers Selon les elements du constructeur	Resistente Resistant Widerstehend Résistant	Astm C-650	In Accordance		
Resistenza al gelo Frost resistance Frostbeständigkeit Résistance au gel	Iso 10545.12	Richiesta Requested Angefordert Demandée	Resistente Resistant Widerstehend Résistant	Astm C-1026	In Accordance		
Resistenza dei colori alla luce Colour resistance to light Lichtbeständigkeit der Farben Résistance des couleurs à la lumière	Din 51094	Nessuna alterazione No alteration Keine Veränderung Aucune altération	Conforme In accordance Erfüllt Conforme				
Resistenza allo scivolamento Slip resistance Rutschfestigkeit Résistance à la glissance	EN 16165C EN 16165A	Secondo i dati del costruttore According to builder's specifications Lautangaben des herstelllers Selon les elements du constructeur	Indicata sul catalogo indicated on the catalogue im prospekt angegeben indiqué sur le catalogue	Astm C-1028 Ansi Dcof 137.1 - 2012	Available on request		

CLASSIFICAZIONE SECONDO NORME CEN/ISO GRUPPO BIII EN 14411/ISO 13006.		CLASSIFICATION IN ACCORDANCE WITH CEN/ISO STANDARDS BIII EN 14411/ISO 13006.		KLASSIFIZIERUNG GEMÄSS CEN/ISO NORMEN GRUPPE BIII EN 14411/ISO 13006.		CLASSIFICATION SELON LES NORMES CEN/ISO GROUPE BIII EN 14411/ISO 13006.	
*VALORE PRESCRITTO: EN 14411 APPENDICE L ISO 13006 BIII		*REQUIRED VALUE: EN 14411 APPENDICE L ISO 13006 BIII		*VORGESCHRIEBENER WERT: EN 14411 APPENDICE L ISO 13006 BIII		*VALEUR PRESCRITE: EN 14411 APPENDICE L ISO 13006 BIII	
Proprietà Fisico-Chimiche Physical-Chemical Properties Pysisch-Chemische Eigenschaften Propriétés Physico-Chimiques	Tipo Di Prova Standard Of Test Testnorm Norme Du Test	Valore Prescritto* Required Value Vorgeschriebener Wert Valeur Prescrite	Valore Standards Norm Norm Normr	Valore medio Mean value Mittelwert Valeur moyenne			
Lunghezza e larghezza Length and width Länge und breite Longueur et largeur	Iso 10545.2	± 0,5%	Conforme				
Ortogonalità Wedging Rechtwinkligkeit Orthogonalité	Iso 10545.2	± 0,5%	Conforme				
Spessore Thickness Stärke Epaisseur	Iso 10545.2	± 10%	Conforme In accordance Erfüllt Conforme				
Planarità Flatness Ebenflächigkeit Planéité	Iso 10545.2	+ 0,5% - 0,3%	Conforme				
Assorbimento d'acqua Water absorption Wasseraufnahme Absorption d'eau	Iso 10545.3	> 10%	Conforme				
Coefficiente di dilatazione termica lineare Coefficient of linear thermal-expansion Lineare wärmeausdehnung Coefficient linéaire de dilatation thermique	Iso 10545.8	Secondo i dati del costruttore According to builder's specifications Lautangaben des herstelllers Selon les elements du constructeur	≈ 6X10 ⁻⁶ C ⁻¹				
Resistenza a flessione spessore Flexion resistance thickness Biegezugfestigkeit stärke Résistance à la flexion epaisseur	Iso 10545.4	≥ 7,5 mm 12 N/mm ² < 7,5 mm 15 N/mm ²	Garantita Guaranteed Garantiert Garantie				
Resistenza agli sbalzi termici Thermal shock resistance Temperaturwechselbeständigkeit Résistance aux écarts de température	Iso 10545.9	Metodo di prova disponibile Test method available Verfügbare prüfmethode Methode d'essai disponible	Garantita Guaranteed Garantiert Garantie				
Resistenza ai prodotti chimici Chemical resistance Chemikalienfestigkeit Résistance aux produits chimiques	Iso 10545.13	Metodo di prova disponibile Test method available Verfügbare prüfmethode Methode d'essai disponible	Disponibile Su Richiesta Available On Request Verfügbare Auf Anfrage Disponible Sur Demande				
Resistenza al gelo Frost resistance Frostbeständigkeit Résistance au gel	Iso 10545.12	Metodo di prova disponibile Test method available Verfügbare prüfmethode Methode d'essai disponible	No No Nein Non				
Resistenza al cavillo Crazing resistance Haarissbeständigkeit Résistance au tressillage	Iso 10545.11	Richiesta Request Bitte Demande	Garantita Guaranteed Garantiert Garantie				

Certificazioni

ENVIRONMENTAL AND QUALITY SYSTEM MANAGEMENT

 Nel corso della propria evoluzione impiantistica Industrie Ceramiche Piemme ha sempre coniugato esigenze di carattere tecnico e produttivo con scelte ecocompatibili, alla continua ricerca di un prodotto che soddisfi le richieste e le aspettative della propria clientela. Industrie Ceramiche Piemme è un'azienda moderna con sistema di gestione certificato ai sensi della norma UNI EN ISO 9001 per la Qualità e UNI EN ISO 14001 per l'Ambiente. L'adozione di modelli standard di riferimento internazionale risponde alla crescente richiesta di competitività, raggiunta attraverso il miglioramento della soddisfazione e della fidelizzazione dei clienti, la razionalizzazione dei processi interni e la conseguente riduzione di sprechi e inefficienze, minimizzando l'impatto ambientale dei processi e prodotti, nel rispetto delle norme.

ENERGY AND SAFETY SYSTEM MANAGEMENT

 Nel 2022 il Sistema di Gestione di Industrie Ceramiche Piemme ha superato le verifiche di conformità ottenendo le importanti Certificazioni ISO 45001 e ISO 50001. Queste due certificazioni, che si vanno ad aggiungere alle precedenti sulla Qualità (ISO 9001) e sull'Ambiente (ISO 14001) sono strategiche per il percorso aziendale in continuo rinnovamento ed innovazione. La prima, la Certificazione ISO 45001, è relativa ai temi della salute e della sicurezza in azienda: questa certificazione attesta che il sistema interno di gestione della sicurezza, oltre ad essere conforme alle normative, è organizzato per perseguire il miglioramento continuo e la riduzione dei fattori di rischio, al fine di tutelare la salute e la sicurezza dei lavoratori. La seconda, la Certificazione ISO 50001, è relativa al tema dell'efficiamento energetico: con questa certificazione l'Azienda ha dimostrato di avere un sistema di gestione dell'energia rispondente alle normative di settore, capace di garantire i seguenti obiettivi: aumentare l'efficienza dei processi, migliorare le prestazioni energetiche puntuali e globali, ridurre i costi specifici dei vettori energetici.

GREEN BUILDING COUNCIL

 Industrie Ceramiche Piemme è socio ordinario del GBC Italia (Green Building Council Italia), associazione no profit nata per favorire e promuovere lo sviluppo dell'edilizia sostenibile e sensibilizzare l'opinione pubblica e le istituzioni sull'impatto che le modalità di progettazione e costruzione degli edifici hanno sulla qualità della vita dei cittadini. I prodotti realizzati da Industrie Ceramiche Piemme contengono materiale riciclato pre-consumer, con un valore percentuale certificato da un Ente riconosciuto a livello internazionale, e che consente di concorrere al raggiungimento dei crediti LEED relativi alla costruzione di edifici eco-sostenibili.

EPD®

 EPD (Environmental Product Declaration) ossia Dichiarazione Ambientale di Prodotto. E' un documento, volontario e verificato da un Ente Ispettivo indipendente, che descrive gli impatti ambientali legati alla produzione di un metro quadrato di piastrella. La Dichiarazione è stata predisposta facendo riferimento all'analisi del ciclo di vita del prodotto basata su uno studio LCA (Life Cycle Assessment), che definisce il consumo di risorse (materiali, acqua, energia) e gli impatti sull'ambiente circostante nelle varie fasi del ciclo di vita del prodotto. Le fasi minime considerate vanno dall'estrazione delle materie prime, il loro trasporto al sito di produzione e la produzione, fino alla dismissione del prodotto stesso.

FDES

 La certificazione FDES costituisce la carta d'identità ambientale dei prodotti, basata sui risultati della relativa Analisi del Ciclo di Vita (LCA) e secondo la norma NF EN 15804+A1 e dal suo supplemento nazionale NF EN 15804/CN. L'Analisi del Ciclo di Vita (LCA) è un metodo strutturato e standardizzato a livello internazionale che permette di quantificare i potenziali impatti sull'ambiente e sulla salute umana associati a un bene o servizio, a partire dal rispettivo consumo di risorse e dalle emissioni.

HPD

 Industrie Ceramiche Piemme ha adottato lo standard collaborativo HPD Dichiarazioni di Salubrità di Prodotto (Health Product Declarations), per comunicare in modo trasparente il contenuto dei propri materiali e il relativo impatto sulla salute. Grazie all'HPD, i nostri prodotti contribuiscono all'ottenimento di crediti LEED® e WELL™.



EMISSIONS DANS L'AIR INTERIEUR

 Le piastrelle prodotte da Industrie Ceramiche Piemme sono inerti da un punto di vista chimico-fisico e durante il loro ciclo di utilizzo, dalla posa fino all'eventuale dismissione, non rilasciano in atmosfera composti organici volatili (COV o VOC (Volatile Organic Compounds)). I materiali Piemme sono pertanto conformi alle prescrizioni normative in materia di COV e consentono di ottenere i crediti previsti dallo standard LEED (Leadership in Energy and Environmental Design).

UPEC

 Numerose serie prodotte da Industrie Ceramiche Piemme vantano la certificazione UPEC, il marchio di qualità francese rilasciato in base ai test previsti dalla normativa europea EN 14411 e dai Cahiers tecnici dell'istituto CSTB. Ad ogni articolo viene assegnata una classificazione che ne attribuisce l'idoneità all'installazione nei diversi ambienti di destinazione.

CCC

 CCC (China Compulsory Certificate) è un marchio di sicurezza obbligatorio per molti prodotti venduti sul mercato cinese.

SASO QUALITY MARK

 È un marchio di qualità obbligatorio per le esportazioni in Arabia Saudita. Il marchio, approvato dall'Organizzazione per gli Standard dell'Arabia Saudita (Saudi Arabian Standards Organization - SASO) indica la conformità di un prodotto agli standard del Paese. I prodotti di Industrie Ceramiche Piemme SpA rispondono agli standard ed ai requisiti definiti dalla norma internazionale SASO ISO 13006:2018 (Piastrille ceramiche - Definizioni, classificazione, caratteristiche e marcatura).

THAI INDUSTRIAL STANDARDS INSTITUTE (TISI)

 Thai Industrial Standards Institute (TISI) è una certificazione di prodotto obbligatoria per le esportazioni in Thailandia. Il suo conseguimento garantisce il rispetto dei requisiti di prodotto fissati dagli standard thailandesi.

CE  **UK CA** 
 Gli articoli realizzati da Industrie Ceramiche Piemme S.p.A. sono conformi al Regolamento N° 305/2011 che definisce le modalità attraverso le quali i produttori di materiali da costruzione devono dichiarare le prestazioni dei prodotti immessi sul mercato. Si tratta di una dichiarazione di conformità a tutela della sicurezza del consumatore, senza la quale il prodotto non può circolare all'interno dei confini dell'Unione Europea. La presenza sull'imballo della Marcatura CE garantisce che Industrie Ceramiche Piemme abbia ottemperato alle disposizioni comunitarie vigenti per l'immissione sul mercato dei prodotti da costruzione.

Elenco delle serie certificate e classificazioni disponibili a richiesta.
 Schede tecniche delle serie certificate disponibili sul sito: www.ceramichepiemme.it

Certifications

ENVIRONMENTAL AND QUALITY SYSTEM MANAGEMENT

 When developing its systems, Industrie Ceramiche Piemme has always combined technical and production requirements with eco-friendly choices, in its continuous quest to produce products that meet the requirements and expectations of its clientele. Industrie Ceramiche Piemme is a modern company with a management system certified pursuant to the UNI EN ISO 9001 standard for Quality and the UNI EN ISO 14001 standard for the Environment. The implementation of standard models that are recognised internationally is a response to the growing demand for competitiveness, achieved by improving levels of customer satisfaction and loyalty, rationalising in-house processes and consequently reducing waste and inefficiency, and minimising the environmental impact of the processes and products, in compliance with the legislation in force.

ENERGY AND SAFETY SYSTEM MANAGEMENT

 In 2022, the Management System of Industrie Ceramiche Piemme passed the compliance checks, obtaining the important ISO 45001 and ISO 50001 Certifications. These two certifications, which are added to the previous ones on Quality (ISO 9001) and Environment (ISO 14001) are strategic for the company path in continuous renewal and innovation. The first, the ISO 45001 Certification, relates to issues of health and safety in the company: this certification certifies that the internal system of safety management, in addition to being compliant with regulations, is organized to pursue continuous improvement and the reduction of risk factors in order to protect the health and safety of workers. The second, the ISO 50001 Certification, relates to the theme of energy efficiency: with this certification, the Company has proven to have an energy management system that complies with industry regulations, able to guarantee the following objectives: increase process efficiency, improve punctual and global energy performance, reduce the specific costs of energy carriers.

GREEN BUILDING COUNCIL

 Industrie Ceramiche Piemme is an ordinary member of the GBC Italia (Green Building Council Italia), a no-profit association founded to favour and promote the development of sustainable construction and raise public awareness, and that of the institutions, on the impact that the methods used to design and construct buildings have on the citizens' quality of life. The products made by Industrie Ceramiche Piemme contain pre-consumer recycled material, with a percentage value that is certified by an internationally recognised Authority, and qualifies for the purposes of acquiring LEED credits for the construction of eco-sustainable buildings.

EPD®

 EPD (Environmental Product Declaration), or Product Environmental Declaration, is a voluntary document verified by an independent inspection body that describes the environmental impacts associated with the production of one square meter of tiles. The declaration was prepared based on a life cycle analysis (LCA - Life Cycle Assessment) study, which defines the consumption of resources (materials, water, energy) and the impacts on the surrounding environment during the various stages of the product's life cycle. The minimum phases considered include the extraction of raw materials, their transport to the production site, production, and the disposal of the product itself.

FDES

 FDES certification defines the environmental identity card of products. It is based on the results of the relevant Life Cycle Analysis (LCA) and is based on the NF EN 15804+A1 standard and its national supplement NF EN 15804/CN. Life Cycle Analysis (LCA) is an internationally standardized evaluation method that quantifies the impacts of a product, service, or process over the span of its life cycle, from extracting raw materials to the end-of-life processing, on the potential impacts on the environment and human health.

HPD

 Industrie Ceramiche Piemme has adopted the HPD (Health Product Declarations) collaborative standard to communicate the contents of its materials and the related impact on health in a transparent manner. Thanks to HPD, our products contribute towards obtaining LEED® and WELL™ credits.



EMISSIONS DANS L'AIR INTERIEUR

 The tiles produced by Industrie Ceramiche Piemme are physically and chemically inert, and during their cycle of use, from laying to removal, if applicable, they do not release Volatile Organic Compounds (COVs or VOCs) into the atmosphere. Piemme materials therefore comply with the terms of the legislation regarding COVs and qualify for the purposes of acquiring the credits envisaged by the LEED standard (Leadership in Energy and Environmental Design).

UPEC

 Many series produced by Industrie Ceramiche Piemme are certified UPEC, the French quality mark issued based on the tests envisaged by the European standard EN 14411 and by the technical Cahiers of the CSTB institute. Each item is assigned with a classification that determines its suitability for installation in various fields of use.

CCC

 The CCC (China Compulsory Certificate) is a safety certificate that is compulsory for many products sold on the Chinese market.

SASO QUALITY MARK

 A quality mark compulsory for exports to Saudi Arabia. The mark, approved by the Saudi Arabian Standards Organization - SASO, confirms a product's compliance with the country's standards. Industrie Ceramiche Piemme S.p.A. products conform to the standards and requirements established by the SASO ISO 13006:2018 international standard (Ceramic tiles – Definitions, classification, characteristics and marking).

THAI INDUSTRIAL STANDARDS INSTITUTE (TISI)

 Thai Industrial Standards Institute (TISI) is a mandatory certification for exports to Thailand. Its achievement compliance with the product requirements set by Thai standards.

CE  **UK CA** 
 The items manufactured by Industrie Ceramiche Piemme S.p.A. comply with Regulation No. 305/2011, which defines the ways in which the producers of building materials must declare the performances of any products introduced to the market. It is a declaration of conformity designed to protect the consumer's safety and without it, the product cannot circulate within the confines of the European Union. The presence of the CE Mark on the packaging guarantees that Industrie Ceramiche Piemme has complied with the European Community provisions in force governing the introduction of building products to the market.

List of certified series and classification available upon request.
 Technical boards of certified series available on the website: www.ceramichepiemme.it

Zertifizierungen



UMWELT- UND QUALITÄTSSYSTEMMANAGEMENT

Im Laufe seiner anlagentechnischen Entwicklung hat Industrie Ceramiche Piemme stets technische bzw. Produktionstechnische Erfordernisse mit umweltbewussten Entscheidungen in Einklang gebracht, im kontinuierlichen Streben nach einem Produkt, das die Wünsche und Erwartungen der Kunden erfüllt. Industrie Ceramiche Piemme ist ein modernes Unternehmen mit einem nach UNI EN ISO 9001 für die Qualität und nach UNI EN ISO 14001 für die Umwelt zertifizierten Managementsystem. Die Anwendung international anerkannter Standardmodelle entspricht dem zunehmenden Bedarf an Wettbewerbsfähigkeit. Diese wiederum wird durch Verbesserung der Kundenzufriedenheit und -bindung, rationelle interne Abläufe und die damit erzielte Reduzierung von Verschwendung und Ineffizienz, sowie durch eine normengerechte Reduzierung der Umweltwirkung von Prozessen und Produkten auf das Minimum erreicht.

ENERGIE- UND SICHERHEITSSYSTEMMANAGEMENT

Im Jahr 2022 hat das Managementsystem von Industrie Ceramiche Piemme die Konformitätsprüfungen bestanden und die wichtigen Zertifizierungen ISO 45001 und ISO 50001 erhalten. Diese beiden Zertifizierungen, die zu den vorherigen für Qualität (ISO 9001) und Umwelt (ISO 14001) hinzugefügt werden, sind strategisch für den Weg des Unternehmens in fortlaufende Erneuerung und Innovation. Die erste, die ISO 45001-Zertifizierung, bezieht sich auf das Gesundheitswesen und Sicherheit im Unternehmen: diese Zertifizierung bescheinigt, dass das interne Sicherheitsmanagementsystem nicht nur den Vorschriften entspricht, sondern auch darauf ausgerichtet ist, eine kontinuierliche Verbesserung und die Reduzierung von Risikofaktoren zu verfolgen, um die Gesundheit und Sicherheit der Arbeitnehmer zu schützen. Die zweite, die ISO 50001-Zertifizierung, bezieht sich auf das Thema Energieeffizienz: mit dieser Zertifizierung hat das Unternehmen nachgewiesen, dass es über ein Energiemanagementsystem verfügt, das den branchenspezifischen Vorschriften entspricht und in der Lage ist, die folgenden Ziele zu gewährleisten: Steigerung der Prozesseffizienz, Verbesserung der punktuellen und globalen Energieleistung, Reduktion der spezifischen Kosten der Energieträger.



Industrie Ceramiche Piemme ist ordentliches Mitglied des GBC Italia (Green Building Council Italien), einer Non-Profit-Organisation für die Förderung des nachhaltigen Bauens und die Sensibilisierung der öffentlichen Meinung und der Behörden für die Wirkung, die die Art und Weise, wie Gebäude geplant und gebaut werden, auf die Lebensqualität der Bürger haben. Die von Industrie Ceramiche Piemme hergestellten Produkte enthalten Pre-Consumer-Recyclingmaterial, dessen Anteil durch eine international anerkannte Prüfstelle zertifiziert ist und das bei der Vergabe der LEED-Punkte den Bau ökologisch nachhaltiger Gebäude angerechnet wird.



EPD (Environmental Product Declaration) oder Umweltproduktdeklaration ist ein freiwilliges Dokument, das von einer unabhängigen Prüfstelle verifiziert wurde und die mit der Herstellung eines Quadratmeters Fliesen verbundenen Umweltauswirkungen beschreibt. Die Deklaration wurde auf Grundlage einer Lebenszyklusanalyse (LCA - Life Cycle Assessment) erstellt, die den Ressourcenverbrauch (Materialien, Wasser, Energie) und die Auswirkungen auf die Umwelt in den verschiedenen Phasen des Lebenszyklus des Produkts definiert. Die mindestens betrachteten Phasen umfassen die Gewinnung der Rohstoffe, ihren Transport zum Produktionsstandort, die Produktion sowie die Entsorgung des Produkts selbst.



FDES Die FDES-Zertifizierung stellt die Umweltidentitätskarte der Produkte dar, basierend auf den Ergebnissen der entsprechenden Lebenszyklusanalyse (LCA) und gemäß der Norm NF EN 15804+A1 und der nationalen Ergänzung NF EN 15804/CN. Die Lebenszyklusanalyse (LCA) ist eine strukturierte und international standardisierte Methode, die es ermöglicht, ausgehend vom jeweiligen Ressourcenverbrauch und den Emissionen, die potenziellen Auswirkungen einer Ware oder Dienstleistung auf die Umwelt und die menschliche Gesundheit zu messen.



HPD Industrie Ceramiche Piemme hat den kollaborativen HPD-Standard für Produktgesundheitsdeklarationen übernommen (Health Product Declarations), um den Inhalt der eigenen Artikel und die damit verbundenen Auswirkungen auf die Gesundheit transparent zu kommunizieren. Dank dem HPD tragen unsere Produkte dazu bei, LEED®- und WELL™-Anerkennungen zu erhalten.



Die von Industrie Ceramiche Piemme hergestellten Fliesen sind chemisch-physikalisch inert und geben während ihrer gesamten Nutzungsdauer von der Verlegung bis zur eventuellen Entsorgung keine flüchtigen organischen Verbindungen (VOC, Volatile Organic Compounds) in die Atmosphäre ab. Die Piemme-Materialien erfüllen daher die Richtlinien hinsichtlich der VOC und tragen zum Erhalt der vom LEED-Standard (Leadership in Energy and Environmental Design) vorgesehenen Punkte bei.



Zahlreiche Serien von Industrie Ceramiche Piemme sind nach UPEC zertifiziert, der französischen Qualitätsklassifizierung, die auf Grundlage der durch die europäische Norm EN 14411 und die Prüfberichte des CSTB ausgestellt wird. Jeder Artikel wird klassifiziert, und damit seine Eignung für die Verlegung in den verschiedenen Anwendungsbereichen bescheinigt.



CCC (China Compulsory Certificate) ist ein für viele am chinesischen Markt verkaufte Produkte vorgeschriebenes Sicherheitsprüfzeichen.



SASO QUALITY MARK Ein vorgeschriebenes Gütesiegel für den Export nach Saudi-Arabien. Die vom saudi-arabischen Normungsinstitut (Saudi Arabian Standards Organization - SASO) genehmigte Marke bezeichnet die Übereinstimmung des Produkts mit Vorschriften Saudi-Arabiens. Die Produkte von Industrie Ceramiche Piemme S.p.A. entsprechen den von der internationalen Norm SASO ISO 13006:2018 (Keramische Fliesen und Platten - Definitionen, Klassifizierung, Eigenschaften und Kennzeichnung) vorgesehenen Standards und Anforderungen.



Thai Industrial Standards Institute ist ein obligatorisches Zertifikat für den Warenexport nach Thailand. Dieses Zeugnis garantiert die Produktanforderungen gemäß den thailändischen Standards.

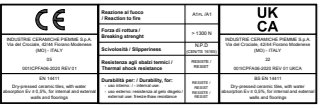

Die von Industrie Ceramiche Piemme S.p.A. produzierten Artikel entsprechen der Verordnung Nr. 305/2011, welche die Modalitäten definiert, mit denen Baustoffhersteller die Leistungen der in den Handel gebrachten Produkte angeben müssen. Es handelt sich um eine Konformitätserklärung zum Schutz der Verbrauchersicherheit, ohne die das Produkt innerhalb der Europäischen Union nicht in Umlauf gebracht werden darf. Das Gütezeichen CE auf der Verpackung garantiert, dass Industrie Ceramiche Piemme die geltenden europäischen Bestimmungen für das Inverkehrbringen der Baumaterialien erfüllt hat.

Liste der geprüften serie und klassifizierungen auf anfrage erhältlich.
Technische karten der bescheinigten serie auf der website verfügbar: www.ceramichepiemme.it

Certifications



GESTION DU SYSTÈME ENVIRONNEMENTAL ET QUALITÉ

Tout au long de son développement, Industrie Ceramiche Piemme a toujours associé les nécessités techniques et productives aux exigences éco-compatibles en s'engageant dans la recherche continue d'un produit satisfaisant les attentes de sa clientèle. Industrie Ceramiche Piemme est une entreprise moderne disposant d'un système de gestion certifié conformément à la norme UNI EN ISO 9001 pour la Qualité et UNI EN ISO 14001 pour l'Environnement. L'adoption de standards internationaux répond à la demande de compétitivité croissante, satisfaite à travers l'amélioration de la satisfaction et de la fidélisation des clients, la rationalisation des processus internes et la réduction conséquente du gaspillage et des inefficiences afin de réduire au minimum l'impact des processus de production sur l'environnement, dans le respect de la réglementation.

GESTION DES SYSTÈMES D'ÉNERGIE ET DE SÉCURITÉ

En 2022, le système de gestion d'Industrie Ceramiche Piemme a passé les contrôles de conformité, obtenant les importantes certifications ISO 45001 et ISO 50001. Ces deux certifications, qui s'ajoutent aux précédentes sur la Qualité (ISO 9001) et sur l'Environnement (ISO 14001) sont stratégiques pour le cheminement de l'entreprise dans le renouvellement et l'innovation continus. La Certification ISO 45001, concerne les enjeux de santé et de sécurité de l'entreprise : celle-ci établit que le système interne de management de la sécurité est organisé pour poursuivre l'amélioration continue et la réduction des facteurs de risques afin de protéger la santé et la sécurité des travailleurs en plus d'être conforme à la réglementation. Deuxièmement la Certification ISO 50001, porte sur la problématique de l'efficacité énergétique : avec cette dernière, l'Entreprise a démontré qu'elle dispose d'un système de management de l'énergie conforme à la réglementation sectorielle, capable de garantir les objectifs suivants : augmenter l'efficacité des processus, améliorer performances énergétiques ponctuelles et globales, réduire les coûts spécifiques des vecteurs énergétiques.



Industrie Ceramiche Piemme est membre ordinaire du gbc italia (green building council italie), l'association à but non lucratif créée pour favoriser et promouvoir le développement de bâtiments à haute qualité environnementale, ainsi que pour sensibiliser l'opinion publique et les institutions sur l'impact que la conception et la construction des bâtiments ont sur la qualité de la vie des citoyens. Les carreaux fabriqués par Industrie Ceramiche Piemme sont issus de matériaux recyclés "pré-consommation", dont le pourcentage est certifié par une entité reconnue internationalement, et qui permet d'acquérir les crédits LEED pour la construction de bâtiments durables.



L'EPD (Environmental Product Declaration), ou Déclaration Environnementale de Produit, est un document volontaire, vérifié par un organisme de contrôle indépendant, qui décrit les impacts environnementaux liés à la production d'un mètre carré de carreaux. La déclaration a été élaborée en se basant sur une analyse du cycle de vie (ACV - Life Cycle Assessment) du produit, qui définit la consommation de ressources (matériaux, eau, énergie) et les impacts sur l'environnement aux différentes étapes du cycle de vie du produit. Les phases minimales prises en compte incluent l'extraction des matières premières, leur transport vers le site de production, la production et la mise au rebut du produit.



FDES La certification FDES constitue la carte d'identité environnementale des produits, basée sur les résultats de l'Analyse de Cycle de Vie (ACV) pertinente et selon la norme NF EN 15804+A1 et son complément national NF EN 15804/CN. L'Analyse du Cycle de Vie (ACV) est une méthode structurée et standardisée au niveau international qui permet de quantifier les impacts potentiels sur l'environnement et la santé humaine associés à un bien ou un service, à partir de la consommation respective de ressources et d'émissions.



HPD Industrie Ceramiche Piemme a adopté la norme collaborative HPD pour les déclarations de salubrité des produits (Health Product Declarations), pour transmettre de manière transparente le contenu de ses matériaux et l'impact sur la santé. Grâce à la norme HPD, nos produits contribuent à l'obtention des crédits LEED® et WELL™.

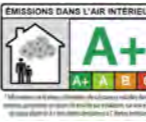

Les carreaux fabriqués par Industrie Ceramiche Piemme sont inertes d'un point de vue chimique et physique. Pendant toute leur durée de vie, de la pose jusqu'à la mise au rebut, ils n'émettent aucun composé organique volatil (COV ou VOC (Volatile Organic Compounds) dans l'atmosphère. Ils sont donc conformes aux exigences réglementaires en matière de COV et permettent d'obtenir les crédits prévus par le standard LEED (Leadership in Energy and Environmental Design).



De nombreuses lignes produites par Industrie Ceramiche Piemme sont certifiées UPEC, la marque de qualité française délivrée après avoir passé les tests prévus par la norme européenne EN 14411 et par les cahiers techniques de l'Institut CSTB. Un classement est attribué à chaque article qui en définit l'aptitude à la pose selon la destination.



CCC (China Compulsory Certificate) est une marque de sécurité obligatoire pour de nombreux produits vendus sur le marché chinois.



LABEL DE QUALITÉ SASO SASO est un label de qualité obligatoire pour les exportations à destination de l'Arabie saoudite. Le label, approuvée par la Saudi Arabian Standards Organization (SASO), indique la conformité d'un produit aux normes du pays. Les produits de Industrie Ceramiche Piemme S.p.A. répondent aux normes et aux exigences définies par la norme internationale SASO ISO 13006:2018 (Carreaux et dalles céramiques - Définitions, classification, caractéristiques et marquage).



Thai Industrial Standards Institute (TISI) est une certification de produit obligatoire pour les exportations en Thaïlande. Son obtention garantit le respect des obligations de produit fixés des standard thaïlandais.

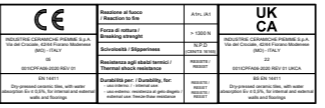

Les carreaux fabriqués par Industrie Ceramiche Piemme S.p.A. sont conformes au Règlement n° 305/2011 qui définit les modalités à travers lesquelles les producteurs de matériaux de construction doivent déclarer les performances des produits qu'ils présentent sur le marché. Il s'agit d'une déclaration de conformité assurant la sécurité du consommateur, sans laquelle le produit ne pourrait pas circuler au sein des frontières de l'Union européenne. Le marquage CE appliqué sur l'emballage est la garantie que Industrie Ceramiche Piemme a satisfait aux dispositions européennes en vigueur réglementant la circulation des matériaux de construction au sein de l'UE.

Liste des séries certifiées et des classements disponibles sur demande.
Fichier technic des séries certifiées disponibles sur le site web: www.ceramichepiemme.it

Allgemeine Geschäftsbedingungen

ART. 1 - VERTRAGSBESTIMMUNGEN

Diese allgemeinen Geschäftsbedingungen gelten, sofern sie nicht schriftlich geändert oder aufgehoben werden, für alle Bestellungen des Käufers (nachstehend „Käufer“ genannt) in Bezug auf die Produkte (nachstehend „Produkte“ genannt) von INDUSTRIE CERAMICHE PIEMME S.P.A. (nachstehend „PIEMME“).

PIEMME ist nicht an die allgemeinen Einkaufsbedingungen des Käufers gebunden, auch dann nicht, wenn auf sie Bezug genommen wird oder sie in den Bestellungen oder anderen vom Käufer selbst stammenden Unterlagen enthalten sind, es sei denn, PIEMME hat vorher schriftlich zugestimmt, wobei in jedem Fall auch die vorliegenden allgemeinen Geschäftsbedingungen gelten.

Im Falle eines Widerspruchs zwischen diesen allgemeinen Geschäftsbedingungen und denjenigen des Käufers, deren Anwendung gemäß dem vorherigen Absatz schriftlich vereinbart wurde, gelten die vorliegenden allgemeinen Geschäftsbedingungen. Diese allgemeinen Geschäftsbedingungen können durch besondere schriftliche Vereinbarungen der Vertragsparteiern ergänzt oder geändert werden, wobei die Wirksamkeit solcher Ergänzungen oder Änderungen auf die jeweilige Bestellung oder den Vertrag beschränkt ist.

ART. 2 - BESTELLUNGEN

Die bei PIEMME eingegangenen Bestellungen sind für PIEMME erst nach ihrer etwaigen schriftlichen Genehmigung verbindlich, wobei PIEMME in jedem Fall das unannehbare Recht hat, die Bestellungen anzunehmen oder – ohne Kosten – vor der Lieferung der Produkte davon zurückzutreten. Jede Auftragsbestätigung von PIEMME, die auch nur teilweise von der Bestellung abweichen sollte, ist für den Käufer verbindlich, wenn er die Nichtbestreimung nicht innerhalb von 5 Tagen nach Erhalt per Einschreiben mit Rückschein oder zertifizierter E-Mail (PEC) beanstandet hat. Wird die Bestellung nur mündlich bestätigt, so gelten mit dem Beginn der Lieferung der Produkte alle in diesen allgemeinen Geschäftsbedingungen festgelegten Bedingungen als vom Käufer vorbehaltlos akzeptiert. Es wird außerdem Folgendes vereinbart: Wenn PIEMME nach der Auftragsbestätigung erfährt, dass die finanziellen Verhältnisse des Käufers die Erfüllung der Verpflichtung zur Zahlung des Produktpreises gefährden sollten (z.B. wenn der Käufer von Insolvenzen, Pfändungen, Beschlagnahmungen oder anderen nachteiligen Handlungen betroffen ist), oder wenn der Käufer sich in den in Art. 1186 des italienischen Zivilgesetzbuches genannten Verhältnissen befindet, hat PIEMME das Recht, die Bestellung aufzuheben und besondere Garantien zu verlangen oder durch eine schriftliche Mitteilung per Einschreiben mit Rückschein oder zertifizierter E-Mail (PEC) vom Vertrag zurückzutreten, wobei in jedem Fall davon das Recht auf Schadensersatz unberührt bleibt. Der Käufer verpflichtet sich, PIEMME mit angemessener Vorfrist, in jedem Fall aber mindestens 48 Stunden vor dem für die Abholung vorgesehenen Termin, schriftlich jede Änderung des Bestimmungsortes der Produkte mitzuteilen, falls dieser von dem in der Auftragsbestätigung genannten abweicht. Erfolgt keine solche Mitteilung, so gilt der ursprünglich angegebene Bestimmungsort als bestätigt.

ART. 3 - MUSTER UND WERBEMATERIALIEN

Die Daten in den erläuternden PIEMME Dokumenten sowie die Merkmale der zugesandten Muster und Modelle sind als ungefähre Angaben zu verstehen. Diese Daten sind nicht verbindlich, soweit dies nicht ausdrücklich in Schriftform vereinbart wurde.

ART. 4 - LIEFERUNG

Sofern nichts anderes schriftlich vereinbart wurde, erfolgt die Lieferung der Produkte immer ab Werk (ab Lager des Verkäufers) gemäß den am Tag der Lieferung geltenden Incoterms und nach Fertigstellung der Ladung in den Lagern von PIEMME in Italien. Alle Transportrisiken, einschließlich Fehlgängen, Brüche, Beschädigungen und Manipulationen, gehen zu Lasten des Käufers, auch wenn der Preis der Produkte portofrei, FOB oder C&F vereinbart wurde. Alle Vereinbarungen mit Speditionen gelten immer als im Namen und auf Rechnung des Käufers abgeschlossen, u.z. aufgrund einer Vollmacht gemäß Art. 1703 ff. des italienischen Zivilgesetzbuches, der ab sofort die Handlungen von PIEMME ratifiziert und akzeptiert.

Die Lieferfristen sind unverbindlich; Lieferverzögerungen, Unterbrechungen, vollständige oder teilweise Aussetzung des Verkaufs geben dem Kunden keinen Anspruch auf Vergütungen oder Schadenersatz. Der Käufer verpflichtet sich, die Produkte abzuholen oder deren Lieferung anzunehmen, sobald ihm ihre Bereitstellung mitgeteilt wird, spätestens jedoch 60 Tage nach dem Datum der Bereitstellungsmitteilung. Wird die Bestellung nicht innerhalb der genannten Frist abgeholt, gilt sie als storniert, unbeschadet des Rechts von PIEMME, den bereits eingezogenen Betrag als Vertragsstrafe einzubehalten, in jedem Fall aber unter Vorbehalt des Schadensersatzes. Jegliche Garantie, Haftung oder Risiko seitens PIEMME in Bezug auf die für den oben genannten Zeitraum geparkten Produkte wird ausdrücklich ausgeschlossen.

Veräumt der Käufer bei der Abholung die Beanstandung etwaiger Fehlgängen, Schäden, Verformungen oder Mängel an der Verpackung, so kann er keine diesbezüglichen Ansprüche mehr geltend machen.

Falls die zwischen den Parteien vereinbarte Incoterms-Regel vorsieht, dass der Käufer für den Transport der Produkte außerhalb Italiens zuständig ist:

a) Im Falle einer innergemeinschaftlichen Veräußerung muss der Käufer PIEMME innerhalb von 45 Tagen nach Ein gang der Produkte in seinem Lager das Original oder eine Kopie des internationalen Beförderungs papiers CMR oder eines anderen, vom Käufer am Bestimmungsort unterzeichneten Transportdokuments oder, in Ermangelung eines CMR, eine Erklärung über den Erhalt der Ware übermitteln;
b) im Falle einer außergemeinschaftlichen Veräußerung verpflichtet sich der Käufer:
i) die Ausfuhranmeldung (Einheitspapier SAD-EX und Administrative Accompanying Document – AAD) vorzulegen und die MRN (Movement Reference Number) beim Zollamt des Gemeinschaftsgebiets, aus dem die Produkte ausgeführt werden, innerhalb von 90 Tagen ab dem Lieferdatum der Produkte in Italien nachzuweisen;
ii) PIEMME innerhalb von 90 Tagen ab dem Datum der Lieferung die Unterlagen zum Nachweis der Ausfuhr der Produkte (SAD-EX-Ausfuhranmeldung, AAD und Nachweis der erfolgten Ausfuhr) zu übermitteln;
iii) PIEMME unverzüglich schriftlich die Erfüllung der vorgenannten Formalitäten zu bestätigen und alle weiteren Dokumente vorzulegen, die die Erfüllung der vorgenannten Formalitäten und den Ausgang der Produkte aus dem Gebiet der Europäischen Union belegen.

Kommt der Käufer den vorgenannten Vereinbarungen nicht nach, hat PIEMME das Recht, dem Käufer sofort die Mehrwertsteuer in Rechnung zu stellen, die mit der Lieferung verbunden ist und die sich auf den fehlenden Nachweis des Transports der Produkte in einen anderen Mitgliedstaat der Europäischen Gemeinschaft oder den fehlenden Nachweis der Ausfuhr bezieht. In jedem Fall hält der Käufer PIEMME schad- und klaglos in Bezug auf die Zahlung jeglicher Beträge, die PIEMME den Steuerbehörden in Form von Sanktionen und Zinsen oder in irgendeiner anderen Form im Zusammenhang mit der Lieferung und dem Nichtnachweis des Transports der Produkte in einen anderen Mitgliedstaat der Europäischen Gemeinschaft oder dem fehlenden Nachweis der Ausfuhr schulden sollte.

ART. 5 - BEANSTANDUNGEN

Die Produktgarantie beschränkt sich ausschließlich auf das keramische Material der ersten Wahl, u.z. mit einer Toleranz von 5 %; für alle Produkte der zweiten oder einer minderwertigeren Wahl oder für Lagerbestände wird ausdrücklich keine Garantie geleistet. Beanstandungen für offensichtliche Fehler sind nur wirksam, wenn sie schriftlich vor der Verlegung der Produkte erfolgen. Farbtonunterschiede stellen keinen Fehler dar, der eine Gewährleistung nach Art. 1490 ff. des italienischen Zivilgesetzbuches begründet. Die Farböne der Muster und der Reproduktionen gelten reichungswesend und sind für den Lieferumfang nicht fest verbindlich. Etwaige Reklamationen wegen Mängeln oder Nichtkonformität der Produkte müssen schriftlich per Einschreiben mit Rückschein oder mit zertifizierter E-Mail (PEC) bei PIEMME eingehen und direkt an unsere Abteilung „Ufficio Logistica, Qualità e Servizio Post-Vendita“ („Logistik, Qualität und Kundendienst“) gerichtet werden, und zwar innerhalb der in Art. 1495 des italienischen Zivilgesetzbuches festgelegten Fristen.

Der Käufer verpflichtet sich, die beanstandeten Lose zur Verfügung zu halten, um die Kontrolle der gemeldeten Mängel oder Nichtkonformitäten zu ermöglichen. In jedem Fall wird darauf hingewiesen, dass die Installation des Materials dessen Annahme voraussetzt und PIEMME von jeglicher Haftung befreit. Der Käufer darf die Produkte unter keinen Umständen ohne die ausdrückliche vorherige schriftliche Genehmigung von PIEMME zurücksenden. Eventuelle Mängel oder Nichtkonformitäten der Produkte, die innerhalb der gesetzlich vorgesehenen Fristen gemeldet und von PIEMME festgestellt oder anerkannt werden, berechtigen PIEMME nur auf der Grundlage einer vorherigen schriftlichen Vereinbarung und der vorherigen Rücksendung der mangelhaften oder nicht konformen Produkte an PIEMME zum Ersatz der Produkte, unter Verzicht auf jegliche weitere Aktion, Forderung, Aufforderung oder jegliches Rechtsmittel, auch zum Zweck des Schadensersatzes. PIEMME haftet nicht für die Eignung der Produkte für den vom Käufer beabsichtigten Verwendungszweck, auch nicht für den Fall, dass PIEMME Empfehlungen oder Hinweise zur Installation und Verwendung der Produkte erteilen sollte, die in jedem Fall für den Käufer als nicht verbindlich gelten.

Erweist sich die Beanstandung als unberechtigt, ist der Käufer verpflichtet, PIEMME alle Kosten zu ersatzten, die PIEMME für die Untersuchung und die außergerichtliche Bearbeitung der Reklamation entstanden sind (Reisen, Garachten usw.); die gleiche Verpflichtung trifft den Käufer, wenn die Reklamation nur teilweise begründet ist.

ART. 6 - PREISE

Die in den Preislisten von PIEMME angegebenen Preise verstehen sich ab Werk (ab Lager des Verkäufers), ohne Mehrwertsteuer und Rabatte. Diese Preise enthalten unter anderem nicht die Kosten für Versand, Transport, eventuelle Versicherungen oder sonstige Abgaben (Steuern, Gebühren usw.). Der Preis der Produkte wird der jeweils am Zeitpunkt der Auftragsbestätigung gültige Listenpreis sein, oder der in der Bestellung angegebene Preis, falls die Produkte nicht in der Preisliste enthalten sind. PIEMME ist auch nach der Auftragsbestätigung bis zur Lieferung der Ware berechtigt, Preisänderungen aufgrund von Erhöhungen der Rohstoff-, Lohn-, Energie- und sonstigen Produktionskosten anzuordnen. In einem solchen Fall kann der Käufer innerhalb von 30 Tagen nach Erhalt der Mitteilung von PIEMME über die Preisänderung der Produkte durch schriftliche Mitteilung per Einschreiben mit Rückschein oder zertifizierter E-Mail (PEC) vom Vertrag zurücktreten.

ART. 7 - ZAHLUNG

Sofern keine anderslautende schriftliche Vereinbarung vorliegt, muss die Zahlung an den Sitz von PIEMME oder an eine von PIEMME angelegte Bank erfolgen. Etwaige Zahlungen an Händler, Vertreter oder Vertriebspersonal von PIEMME haben, sofern sie zuvor von PIEMME schriftlich genehmigt wurden, sind für den Käufer schuldfreiend. Jede Verspätung oder Unregelmäßigkeit bei der Zahlung berechtigt PIEMME, die Lieferungen einzustellen und die laufenden Verträge aufzulösen, auch wenn sich diese nicht auf die betroffenen Zahlungen beziehen, unbeschadet des Rechts auf Schadensersatz. Bei Zahlungsverzug des Käufers werden, ohne dass eine Inverzugesung erforderlich ist, Verzugszinsen in Höhe des von ital. gesetzestretterenden Dekrets Nr. 231/2002 vorgesehenen Zinssatzes auf die vollständige Rücksetzung der Anwaltskosten und der so wohl außergerichtlichen wie auch gerichtlichen Betreuungskosten in Rechnung gestellt. Der Käufer darf die Zahlung in keinem Fall verspäten oder einstellen, ganz unabhängig von jeder Forderung und/oder jeder geltend gemachten Reklamation.

Die Beanstandung von Mängeln oder Nichtkonformitäten sowie alle anderen zwischen PIEMME und dem Käufer bestehenden Streitigkeiten im Zusammenhang mit der Erfüllung der Kaufverträge über die Produkte sind unwirksam und können nicht berücksichtigt werden, ebenso wenig wie die Einleitung eines Verfahrens vor der vollständigen Zahlung des Preises (Klausel „solve et repete“).

ART. 8 - EIGENTUMSVORBEHALT

Der Verkauf der Produkte erfolgt mit der Klausel des Eigentumsvorbehalts; daher bleiben die gelieferten Produkte bis zur vollständigen Bezahlung des Preises Eigentum von PIEMME, falls die Zahlung aufgrund vertraglicher Vereinbarungen ganz oder teilweise nach der Lieferung erfolgen muss.

ART. 9 – GRÜNDE HÖHERER GEWALT UND ÜBERMÄSSIGER HÄRTE

PIEMME kann ohne Kosten, Strafen und Haftung jeglicher Art, auch ohne Entschädi-

gung, die Erfüllung des Vertrags ganz oder teilweise einstellen oder ganz oder teilweise davon zurücktreten, falls die Erfüllung aufgrund von Ereignissen höherer Gewalt (ohne Anspruch auf Vollständigkeit, Streiks, Unfälle, Explosionen, Brände, Kriege, Naturereignisse, Epidemien, gesetzliche Verbote, Mangel, Verspätungen oder Schwierigkeiten bei der Versorgung mit Rohstoffen, Betriebsstörungen und/oder ähnliche Ursachen usw.) objektiv unmöglich oder mit übermäßiger Härte verbunden ist.

ART. 10 - VERTRAGSABTRETUNG

Der Käufer darf den Vertrag oder einzelne sich daraus ergebende Verpflichtungsverhältnisse nicht ohne schriftliche Zustimmung von PIEMME abtreten; auch in diesem Fall haftet der Käufer jedoch gesamtschuldnerisch mit dem Abtretungsempfänger für die abgetretenen Verpflichtungen.

ART. 11 - AUSLEGUNG, ÄNDERUNGEN, UNGÜLTIGE KLAUSELN

Für die Auslegung der vorliegenden allgemeinen Geschäftsbedingungen ist ausschließlich der italienische Text dieser allgemeinen Geschäftsbedingungen maßgebend.

Etwaige Anhänge oder Präambeln gelten als wesentlicher Bestandteil der Verträge, auf die sie sich beziehen.

Jeder Verweis auf Preislisten, allgemeine Geschäftsbedingungen oder sonstiges Material von PIEMME gilt als Bezugnahme auf die zum Zeitpunkt des Verweises geltenden Dokumente, sofern nichts anderes angegeben ist; entsprechende Texte, die zuvor zwischen den Parteien in Kraft waren, gelten als nichtig.

Die von den Vertragspartnern während der Verhandlungen oder im Laufe der Vertragsausführung abgegebenen Erklärungen oder Verhalten können nur zur Auslegung des Vertrages beitragen, auf die sie sich beziehen und nur soweit sie nicht mit den vorliegenden allgemeinen Geschäftsbedingungen oder den schriftlichen Vereinbarungen zwischen den Vertragspartnern bei der Schließung des betroffenen Vertrages im Widerspruch stehen.

Vorbehaltlich der Bestimmungen unter Art. 2) sind alle Änderungen oder Ergänzungen der Verträge, auf die diese allgemeinen Geschäftsbedingungen Anwendung finden, bei sonstiger Nichtigkeit in Schriftform durchzuführen. Die Abweichung von einer oder mehreren Bestimmungen dieser allgemeinen Geschäftsbedingungen darf nicht darf nicht als ausdehnend oder nach Ähnlichkeit ausgelegt werden und zieht nicht den Willen nach sich, von der Anwendung der allgemeinen Bedingungen in ihrer Gesamtheit abzusehen.

Eventuelle Veränderungen der zwischen den Vertragspartnern vereinbarten Vertragsbedingungen stellen keine Vertragsneuerung dar, sofern nicht ausdrücklich schriftlich anders vereinbart. Im Falle von nicht gültigen oder unwirksamen Vertragsbestimmungen ist der Vertrag in seiner Gesamtheit zu ergänzen, um gesetzesgemäß den wesentlichen Zweck zu erreichen, der die betreffenden Klauseln enthält.

Die Duldung eines Verhaltens, das gegen die in diesen allgemeinen Geschäftsbedingungen enthaltenen Bestimmungen verstößt, bedeutet weder einen Verzicht auf die Rechte, die sich aus den verletzten Bestimmungen ergeben, noch auf das Recht, die genaue Erfüllung aller hierin enthaltenen Bestimmungen zu verlangen.

ART. 12 – GERICHTSSTAND

Der vorliegende Vertrag unterliegt dem italienischen Recht, auch in Prozessen. Für alle Streitigkeiten im Zusammenhang mit den Verträgen, für die diese allgemeinen Geschäftsbedingungen gelten, ist der italienische Richter zuständig. Für alle Streitigkeiten, die sich aus der Auslegung und Anwendung der vorliegenden allgemeinen Geschäftsbedingungen ergeben, ist das Gericht von Reggio Emilia zuständig.

ART. 13 - GEWERBLICHES EIGENTUM UND BESCHRÄNKTER VERTRIEB – EINSCHRÄNKUNGEN FÜR DEN WEITERVERKAUF

Die Unterzeichnung der vorliegenden allgemeinen Geschäftsbedingungen gibt dem Käufer nicht das Recht, die Markenzeichen von PIEMME und/oder sonstige Kennzeichen derselben in irgendeiner Form zu verwenden; ihre eventuelle Verwendung muss zuvor von PIEMME genehmigt und ausdrücklich in einem gesonderten Schriftstück geregelt werden.

Die von PIEMME gelieferten Produkte sind für die Installation beim Endverbraucher bestimmt. Ein Weiterverkauf an andere gewerbliche Zwischenhändler als den Endverbraucher ist nur mit vorheriger schriftlicher Genehmigung von PIEMME zulässig, es sei denn, der Kauf der Produkte erfolgt bei ausdrücklich von PIEMME dafür zugelassenen Verkaufsstellen. Der Weiterverkauf von Produkten unter Verstoß gegen dieses Verbot ist somit als unzulässig und als unerlaubter Gebrauch der gewerblichen und geistigen Eigentumsrechte von PIEMME zu betrachten, wobei PIEMME selbst das Recht hat, die Beschlagnahme bei egal welchem Produktinhaber zu verlangen. Es versteht sich, dass PIEMME sich das Recht vorbehält, rechtliche Schritte gegen jeden einzuleiten, der am unerlaubten Weiterverkauf beteiligt ist.

ART. 14 - ZUSAMMENFASSENDE INFORMATIONEN

Gemäß Art. 13 der EU-Verordnung 2016/679 informieren wir Sie darüber, dass Ihre Daten sowohl in elektronischen als auch in Papierdateien/Dateien gespeichert und von berechtigten Personen ausschließlich zu Verwaltungs- und Buchhaltungszwecken verarbeitet werden. Die Daten können zum Zweck der Durchführung bestehender Beziehungen oder zur Erfüllung gesetzlicher Verpflichtungen an Dritte weitergegeben werden, werden aber nicht verbreitet. Wir informieren Sie auch darüber, dass Sie jederzeit Zugang zu den Daten verlangen und bestimmen Verwendungen der Daten widersprechen können, indem Sie sich an den Verantwortlichen der Verarbeitung wenden.

Anmerkung: Diese zusammenfassenden Informationen werden durch weitere ausführliche Informationen ergänzt, die am Sitz des Unternehmens kostenlos erhältlich sind und/oder auf der Website des Unternehmens https://www.ceramichepiemme.de/unter folgendem Link „Datenschutzerklärung“ https://www.ceramichepiemme.de/daten-schutzklarung eingesehen werden können.

Conditions générales de vente

ARTICLE 1 - RÈGLEMENTS CONTRACTUELS

Les présentes conditions générales, sauf modification ou dérogation par écrit, régissent toutes les commandes de l'acheteur (ci-après « l'acheteur ») concernant les produits (ci-après « Produits ») de l'entreprise INDUSTRIE CERAMICHE PIEMME S.P.A. (ci-après « PIEMME »).

PIEMME ne sera pas liée par des conditions générales d'achat de l'acheteur, même s'il y est fait référence ou si elles sont contenues dans les commandes ou dans toute autre documentation provenant de l'acheteur lui-même, sauf consentement écrit préalable de PIEMME, nonobstant, dans tous les cas, l'application également des présentes conditions générales.

En cas de conflit entre les présentes conditions générales et celles de l'acheteur, lorsque leur application a été convenue par écrit conformément au paragraphe précédent, les présentes conditions générales s'appliquent. Les présentes conditions générales peuvent être intégrées ou modifiées par des accords spécifiques pris par les parties par écrit, étant entendu que l'efficacité de ces intégrations ou modifications sera limitée à la commande ou au contrat spécifique.

ARTICLE 2 - COMMANDES

En tout état de cause, les commandes reçues par PIEMME ne seront contraignantes pour cette dernière qu'après leur éventuelle approbation par écrit, PIEMME ayant en tout cas le droit incontestable de les accepter ou de s'en rétracter - sans frais - avant la livraison des Produits. Toute confirmation de commande par PIEMME qui serait, même partiellement, différente de la commande, engagera l'acheteur qui n'a pas contesté la non-conformité par lettre recommandée avec accusé de réception ou PEC, dans les 5 jours suivant sa réception.

Dans le cas où la commande n'est confirmée qu'oralement, avec le début de la livraison des Produits, toutes les conditions énoncées dans les présentes conditions générales sont réputées acceptées par l'acheteur sans réserve.

Il est également convenu que si, après la confirmation de la commande, PIEMME apprend que les conditions financières de payer les produits sont devenues telles qu'elles compromettent l'exécution de l'obligation de payer le prix des Produits (à titre d'exemple, si l'acheteur a fait l'objet de protêts, de séquestres, de saisies ou d'autres actes préjudiciables), ou que l'acheteur se trouve dans les conditions prévues par l'article 1186 du Code civil italien, PIEMME aura le droit de suspendre la commande et d'exiger des garanties spéciales ou de résilier le contrat par communication écrite par lettre recommandée avec accusé de réception ou PEC, sans préjudice, en tout cas, du droit à la réparation de tout dommage.

L'acheteur s'engage à communiquer par écrit à PIEMME, en temps voulu, en tout cas pas moins de 48 heures avant la date prévue pour l'enlèvement, toute variation du lieu de destination des Produits si celui-ci diffère du lieu mentionné dans la confirmation de la commande. En l'absence d'une telle notification, la destination initialement indiquée est réputée confirmée.

ARTICLE 3 - ÉCHANTILLONS ET MATÉRIEL PROMOTIONNEL

Les données figurant dans les documents illustratifs de PIEMME, ainsi que les caractéristiques des échantillons et modèles envoyés, sont des indications approximatives. Ces données ne sont pas contraignantes, sauf accord exprs par écrit.

ARTICLE 4 - LIVRAISON

Sauf accord écrit contraire, la livraison des Produits sera toujours considérée comme Départ usine (départ entrepôt du vendeur) conformément aux Incoterms en vigueur à la date de livraison et chargement dans les entrepôts de PIEMME en Italie. Tous les risques de transport, y compris manques, ruptures, détériorations et altérations, sont à la charge de l'acheteur même si le prix des Produits a été convenu franco de port, FOB ou CFR. Les éventuels accords avec les transitaires sont toujours considérés comme conclus au nom et pour le compte de l'acheteur, en vertu d'un mandat aux termes de l'article 1703 et suivants du Code civil italien qui, dès à présent, ratifie et accepte les actions de PIEMME.

Les délais de livraison ont un caractère indicatif : les retards de livraison, les interruptions, les suspensions totales ou partielles des ventes ne donnent pas droit à une indemnisation ou à des dommages et intérêts. L'acheteur s'engage à retirer les Produits ou à en prendre livraison dès qu'il est informé qu'ils sont prêts, et en tout cas au plus tard dans les 60 jours à compter de la date de notification de marchandise prête. Par défaut de retrait dans le délai susmentionné, la commande sera considérée comme annulée, sans préjudice du droit de PIEMME de conserver le montant déjà perçu à titre de pénalité, sous réserve, en tout état de cause, de dommages et intérêts. En ce qui concerne les Produits entreposés pendant la période susmentionnée, toute garantie, toute responsabilité ou tout risque à la charge de PIEMME sont expressément exclus.

Le défaut de notification à l'acheteur, au moment du retrait, de manques, de ruptures, de non-conformités ou de défauts dans l'emballage des marchandises, empêche l'acheteur de faire toute réclamation ultérieure à cet égard.

Si la règle Incoterms convenue entre les parties prévoit que l'acheteur doit organiser le transport des Produits en dehors de l'Italie :

a) en cas de transfert intracommunautaire, l'acheteur, dans un délai de 45 jours à compter de la réception des Produits dans son entrepôt, devra transmettre à PIEMME un original ou une copie du document de transport international CMR ou autre document de transport, signé à destination par l'acheteur ou, en l'absence de CMR, une déclaration de réception des marchandises ;
b) en cas de transfert extracommunautaire, l'acheteur s'engage à :
i) présenter la déclaration en douane d'exportation (DAU-EX et DAE) et faire l'apurement du MRN (Movement Reference Number/Numéro de référence du mouvement) auprès de la douane du territoire communautaire de sortie des Produits, dans les 90 jours à compter de la date de livraison des Produits en Italie ;
ii) envoyer à PIEMME, dans un délai de 90 jours à compter de la date de livraison, les documents prouvant l'exportation des Produits (déclaration d'exportation DAU-EX, DAE et notification d'exportation) ;

En cas où le paiement, en raison d'accords contractuels, doit être effectué en tout ou partie après la livraison, les Produits livrés restent la propriété de PIEMME jusqu'au paiement intégral du prix.

Dans le cas où l'acheteur ne respecterait pas ce qui précède, PIEMME aura le droit de facturer immédiatement à l'acheteur la Taxe sur la Valeur Ajoutée relative à la fourniture et liée à l'absence de preuve du transport des Produits vers un autre État membre de la Communauté Européenne ou au défaut d'apurement de l'exportation. En tout état de cause, l'acheteur tiendra PIEMME quitte et indemne du paiement de toute somme susceptible d'être due par PIEMME à l'Administration fiscale, à titre de pénalités et d'intérêts ou à tout autre titre, en relation avec la fourniture et l'absence de preuve du transport des Produits vers un autre État membre de la Communauté européenne ou le défaut d'apurement de l'exportation.

ARTICLE 5 – CONTESTATIONS

Les garanties sur les produits sont limitées au matériel céramique de premier choix uniquement, avec une tolérance de 5 % ; toute garantie est expressément exclue pour tous les produits de deuxième choix, de choix secondaire et en stock. Les réclamations pour vices apparents ne produisent des effets que si elles sont formulées par écrit avant la pose des produits. Les différences de tonalité ne constituent pas un vice donnant lieu à la garantie au sens des articles 1490 et suivants du Code civil italien. Les teintes des échantillons et reproductions doivent être considérées comme purement indicatives et non strictement contraignantes dans le cadre de la livraison. Les éventuelles réclamations pour vices ou non-conformités des Produits devront parvenir à PIEMME par écrit, par lettre recommandée avec accusé de réception ou PEC, directement à l'attention de notre « Ufficio Logistica, Qualità e Servizio Post-Vendita » (Département Logistique, Qualité et Service après-vente), dans les termes et conditions prévus par l'article 1495 du Code civil italien.

L'acheteur s'engage à mettre à disposition les lots objets de la réclamation afin que les vices ou les non-conformités signalés puissent être vérifiés. En tout état de cause, nous rappelons que la pose du matériel implique son acceptation et exonère PIEMME de toute responsabilité. L'acheteur ne pourra, en aucun cas, retourner les Produits sans l'autorisation expresse, préalable et écrite de PIEMME. Les éventuels vices ou non-conformités des Produits, dans la mesure où ils sont signalés dans les termes et conditions prévus par la loi et constatés ou reconnus par PIEMME, donnent droit uniquement au remplacement des Produits à condition d'un accord écrit préalable et de la restitution préalable à PIEMME des Produits défectueux ou non-conformes, avec renonciation à d'autres actions, réclamations, demandes ou recours quelconques, même de caractère compensatoire.

PIEMME décline toute responsabilité quant à l'adéquation des Produits à l'usage que l'acheteur entend en faire, même dans le cas où des suggestions ou des indications quant à l'installation et à l'utilisation de ceux-ci seraient fournies par PIEMME, lesquelles ne seront en aucun cas considérées comme contraignantes pour l'acheteur. Si la réclamation s'avère non fondée, l'acheteur sera tenu de rembourser à PIEMME tous les frais engagés par PIEMME pour la vérification et la gestion extrajudiciaire de la réclamation (déplacements, expertises, etc.). L'acheteur aura la même obligation si la réclamation s'avère seulement partiellement fondée.

ARTICLE 6 - PRIX

Les prix figurant sur les listes de prix de PIEMME s'entendent Départ usine (départ entrepôt du vendeur), hors TVA et remises. Ces prix ne comprennent pas, entre autres, les frais d'expédition, de transport, d'assurance éventuelle, ni d'autres frais (taxes, droits, etc.). Le prix des Produits est celui de la liste de prix en vigueur au moment de la confirmation de la commande ou, si les Produits ne figurent pas dans la liste de prix, leur prix sera celui mentionné dans la commande. Même après confirmation de la commande et jusqu'au moment de la livraison des marchandises, PIEMME aura le droit de modifier les prix en raison de l'augmentation du coût des matières premières, de la main-d'œuvre, de l'énergie et d'autres coûts de production. Dans ce cas, l'acheteur pourra se rétracter du contrat par notification écrite, à envoyer par lettre recommandée avec accusé de réception ou PEC, dans un délai de 30 jours à compter de la réception de la communication par PIEMME de la variation du prix des Produits.

ARTICLE 7 - PAIEMENT

Le paiement sera effectué, sauf accord écrit contraire, dans les locaux de PIEMME ou auprès d'une banque indiquée par PIEMME. Tout paiement effectué à des agents, représentants ou auxiliaires commerciaux de PIEMME, dans la mesure où il a été préalablement autorisé par écrit par PIEMME, aura pour effet de libérer l'acheteur.

Tout retard ou toute irrégularité dans le paiement des Produits autorisera PIEMME à suspendre les fournitures ou à résilier les contrats en cours, même s'ils ne sont pas liés aux paiements en question, sans préjudice, en tout état de cause, du droit à la réparation des dommages éventuels. Le retard de paiement par l'acheteur entraîne, sans qu'il soit nécessaire de procéder à une mise en demeure, l'application d'intérêts moratoires au taux prévu par le décret législatif italien n° 231/2002 jusqu'au remboursement intégral des frais de justice et d'assistance, tant extrajudiciaires que judiciaires. L'acheteur ne pourra en aucun cas retarder ou suspendre le paiement, quelles que soient les réclamations et/ou plaintes formulées.

Aucune contestation sur les vices ou non-conformités, ainsi que sur tout autre litige existant entre PIEMME et l'acheteur concernant l'exécution des contrats de vente des Produits, ne produira d'effets ni ne pourra être prise en considération, de même qu'aucune action ne pourra être engagée avant le paiement complet du prix (clause solve et repete).

ARTICLE 8 - RÉSERVE DE PROPRIÉTÉ

La vente des Produits implique une clause de réserve de propriété. En conséquence, dans le cas où le paiement, en raison d'accords contractuels, doit être effectué en tout ou partie après la livraison, les Produits livrés restent la propriété de PIEMME jusqu'au paiement intégral du prix.

ARTICLE 9 - FORCE MAJEURE ET ONÉROSITÉ EXCESSIVE

PIEMME peut, sans charges, pénalités ou responsabilités de toute sorte et nature, même pas de nature compensatoire, suspendre, en tout ou en partie, l'exécution du contrat, ou se rétracter, en tout ou en partie, de ce contrat, si l'exécution est objectivement impossible ou excessivement onéreuse, en raison d'événements de force majeure (sans aucune prétention d'exhaustivité, grèves, accidents, explosions, incendies, guerres, événements

naturels, épidémies, interdictions légales, absence, retards ou difficultés d'approvisionnement en matières premières, pannes et/ou causes similaires, etc.).

ARTICLE 10 - CESSIION DU CONTRAT

L'acheteur ne peut pas céder le contrat, ou les différents rapports d'obligation en décaulant, sans l'acceptation écrite de PIEMME. Même dans ce cas, l'acheteur reste toutefois responsable solidairement avec le cessionnaire, des obligations cédées.

ARTICLE 11 - INTERPRÉTATION, MODIFICATIONS, CLAUSES INVALIDES

Pour l'interprétation des présentes conditions générales, seule la version italienne fait foi.

Les annexes ou les introductions sont réputées faire partie intégrante des contrats auxquels elles se rapportent.

Toute référence à listes de prix, conditions générales ou autres documents de PIEMME est réputée se rapporter aux documents en vigueur au moment de la référence, sauf indication contraire. Tout texte précédent en vigueur entre les parties est réputé nul et non venu.

Les déclarations faites ou le comportement adopté par les parties, lors des négociations ou au cours de l'exécution du contrat, peuvent contribuer uniquement à l'interprétation du contrat auquel ces déclarations et comportement se rapportent et dans la mesure où ils ne s'opposent pas aux présentes conditions générales ou aux accords conclus par écrit par les parties lors de la signature du contrat en question.

Sauf dans les cas prévus à l'art. 2) ci-dessus, les modifications ou les intégrations apportées par les parties aux contrats auxquels s'appliquent les présentes conditions générales, doivent être faites par écrit, sous peine de nullité. La renonciation à une ou plusieurs dispositions des présentes conditions générales ne doit pas être interprétée de manière extensive ou par analogie, ni n'implique l'intention de ne pas appliquer les conditions générales dans leur ensemble.

Les modifications des conditions contractuelles convenues entre les parties ne constituent pas une novation du contrat, sauf mention contraire expresse et écrite. En cas de dispositions contractuelles invalides ou inefficaces, le contrat doit être intégré dans son ensemble afin d'atteindre, d'une manière conforme à la loi, l'objectif essentiel poursuivi par l'accord contenant les clauses en question.

L'éventuelle tolérance de comportements, en violation des dispositions contenues dans les présentes conditions générales, ne constitue pas une renonciation aux droits découlant des dispositions violées ni au droit d'exiger la bonne exécution de tous les termes et conditions prévus.

ARTICLE 12 - TRIBUNAL COMPÉTENT

Le présent contrat est régi par le droit italien, y compris le droit procédural. Pour tout litige relatif ou lié de quelque manière que ce soit aux contrats auxquels s'appliquent les présentes conditions générales, la compétence est attribuée aux tribunaux italiens. Tout litige découlant de l'interprétation et de l'exécution des présentes conditions générales sera réglé par le tribunal de Reggio Emilia.

ARTICLE 13 - PROPRIÉTÉ INDUSTRIELLE ET DISTRIBUTION SÉLECTIVE – LIMITES DE REVENTE

La signature des présentes conditions générales ne donne, en aucun cas, à l'acheteur le droit d'utiliser, sous quelque forme que ce soit, les marques de PIEMME et/ou d'autres signes distinctifs de cette dernière. Leur utilisation éventuelle devra être préalablement autorisée par PIEMME et expressément réglementée dans un acte séparé. Les fournitures de Produits PIEMME sont destinées à être installées dans les locaux de l'utilisateur final et aucune autre forme de revente à des intermédiaires commerciaux autres que les utilisateurs finaux n'est autorisée, sauf autorisation écrite préalable de PIEMME et sauf si l'achat des Produits a lieu dans des points de vente expressément autorisés par PIEMME à cet effet. La revente de Produits en violation de cette interdiction doit donc être considérée comme non autorisée et assimilée à une utilisation illicite des droits de propriété industrielle et intellectuelle de PIEMME, avec le droit pour PIEMME d'en demander la saisie auprès de tout détenteur. Il est entendu que PIEMME se réserve le droit d'engager des poursuites judiciaires contre toute personne impliquée dans une revente non autorisée.

ARTICLE 14 - INFORMATION SOMMAIRE

Conformément à l'art. 13 du règlement UE 2016/679, nous vous informons que vos données sont stockées dans des bases de données électroniques et papier et sont traitées par des personnes autorisées exclusivement à des fins administratives et comptables. Les données pourront être communiquées à des tiers pour l'exécution de relations existantes ou pour l'accomplissement d'obligations légales, mais ne seront pas divulguées. Nous vous informons également que vous pouvez, à tout moment, demander l'accès aux données et vous opposer à certaines utilisations en contactant le Responsable du traitement.

Remarque : Cette information sommaire est complétée par d'autres informations méthodiques et exhaustives, disponibles gratuitement auprès du siège social et/ou consultables sur le site Web de la société: https://www.ceramichepiemme.fr, en cliquant sur le lien suivant « Informations sur la protection de la vie privée » https://www.ceramichepiemme.fr/privacy.

Project Management
Mktg Piemme

Finito di stampare a Febbraio 2026
Printed in February 2026



CERAMICHEPIEMME

FLOOR AND MORE

INDUSTRIE CERAMICHE PIEMME S.P.A.
VIA DEL CROCIALE 42/44, 41042 FIORANO (MO) - ITALY
T. +39 0536.849111 - F. +39 0536.849402
WWW.CERAMICHEPIEMME.IT - INFO@CERAMICHEPIEMME.IT